

Wahikuli-Honokōwai Watershed Management Plan

Volume 2: Strategies and Implementation



A component of the West Maui Ridge to Reef Initiative

December 2012

Prepared for:



Office of Ocean and Coastal Resource Management
National Oceanic and Atmospheric Administration
1305 East-West Highway
Silver Spring, MD 20910

Prepared by:



SUSTAINABLE RESOURCES GROUP INTN'L, INC.
111 Hekili Street, Suite A373
Kailua, HI 96734
Tel/Fax: 808-356-0552 • www.srgii.com

Disclaimer: The accuracy, completeness, and correctness of the source data for this report and of the conclusions or statements made in reliance on such data have not been independently verified and cannot be guaranteed. The views and opinions of authors and contributors expressed in this report do not necessarily state or reflect those of the United States Government, the State of Hawai‘i, or the County of Maui.

Production Note: The Wahikuli-Honokōwai Watershed Management Plan has been developed as a two volume document: *Volume 1: Watershed Characterization*, and *Volume 2: Strategies and Implementation* (this document). The complete plan characterizes the project watersheds (Volume 1); recommends pollution control strategies, outlines implementation strategies, provides evaluation and monitoring protocols, and describes education and outreach approaches (Volume 2).

Executive Summary

Healthy coral reefs are vital to our culture, way of life, and economy. Long-term coral reef monitoring has shown that coral reefs in northern Kā'anapali have declined by as much as 50 percent. The West Maui Region is currently targeted by Federal, State, and private entities for watershed planning efforts with the goals of reducing stressors to and improving the overall health of coral reefs, nearshore waters, and watersheds. The Honolulu District of the U.S. Army Corps of Engineers (USACE) and Hawai'i Department of Land and Natural Resources Division of Aquatic Resources (DLNR-DAR) are the lead government agencies for the West Maui Ridge to Reef (R2R) Initiative, covering five watersheds from Wahikuli to Honolulu.

Over the past century, land use in this region has resulted in export of land-based pollutants that have impaired the water quality of nearshore ocean waters and adversely impacted the marine ecosystem. Land-based pollutants generated across large areas and from diffuse sources are commonly referred to as non-point source (NPS) pollutants. NPS pollutants are transported off the watersheds in both surface water and groundwater and delivered into the ocean at various rates and total loads. Two of the most problematic land-based pollutants identified by scientists are sediment and nutrients (Nitrogen and Phosphorus).

To address the issue, the National Oceanic and Atmospheric Administration (NOAA) Coral Program has sponsored a Watershed Management Plan (WMP) for two watersheds, Wahikuli and Honokōwai, as part of the West Maui R2R Initiative. The *Wahikuli-Honokōwai Watershed Management Plan* (WHWMP) is composed of two volumes: *Volume 1: Watershed Characterization*, and *Volume 2: Strategies and Implementation*. The WHWMP will provide a template for WMPs to be developed for other West Maui watersheds. It adheres to the Environmental Protection Agency (EPA) Clean Water Act (CWA) Section 319 guidelines for watershed plan development. These guidelines require use of a holistic, watershed based approach to identify sources and sinks of NPS pollutants, and the remedial actions necessary to reduce their loads to receiving waters. The complete WHWMP characterizes the project watersheds (Volume 1); and recommends pollution control strategies, outlines implementation strategies, provides evaluation and monitoring protocols, and describes education and outreach approaches (Volume 2).

Volume 2 of the WHWMP discusses strategies for management of NPS pollutants in Wahikuli and Honokōwai Watersheds. These NPS pollutants adversely impact water quality and the coral reef ecosystem, diminishing habitat for plants and animals and resource use by people. The management strategies target pollutants and their sources identified in Volume 1. Major NPS pollutant sources within the watersheds are those land uses, activities, and inputs that have the greatest overall adverse impact to the coral reef ecosystem. Several of these sources cover a significant areal extent within the project area, and may have specific sections or regions that require immediate attention. To refine the discussion of pollutants and their control strategies, the watersheds were delineated into management units (Conservation, Agricultural, and Urban) based on the State-designated Land Use Districts and their corresponding dominant land uses and types.

Section 1, *Introduction*, identifies a vision and goals, defines key terms and summarizes main pollutants and hotspots in the Agricultural and Urban Management Units as characterized in Volume 1. A clear vision and set of goals are supported by management strategies, implementation

1 of which will help achieve reduction of NPS pollutants from the targeted management units. The
 2 vision is aligned with the overarching goal of the West Maui R2R Initiative. Sediment inputs have
 3 been determined to be the key issue with respect to pollution generated in the Agricultural
 4 Management Unit. Pollutants contained in the Lahaina Wastewater Reclamation Facility (WWRF)
 5 effluent that are entering the coral reef environment have been determined to be the key issue with
 6 respect to the Urban Management Unit.

7 Section 2, *Implementation Strategies*, discusses elements required to implement a WMP, financial
 8 considerations, and necessary technical resources. Adaptive management is necessary to improve
 9 management by learning from the outcomes of past activities. It is highly recommended that all
 10 solutions be implemented as soon as possible, however it is recognized that this is likely not
 11 feasible due to financial and labor constraints. Landowner interest and participation is necessary
 12 for successful implementation. The priorities for implementation should not be considered rigid. If
 13 a landowner or entity responsible for a particular parcel has resources to implement a solution that
 14 is lower priority, the opportunity should be taken. Any installation of a management practice is a
 15 positive gain towards reducing NPS pollution, regardless of order or whether it is preventive or
 16 treatment based.

17 Section 3, *Pollution Control Strategies*, identifies projects and management practices recommended
 18 to address identified sources and types of NPS pollutants. Specific practices were selected based on
 19 their ability to reduce generation of, capture, or remediate NPS pollutants; cost; logistical aspects of
 20 installation; and any link to regulatory or management objectives that either require or promote
 21 measures to reduce NPS pollutants. Priority management practices are those deemed most critical
 22 for implementation, while secondary practices are recommended for implementation after priority
 23 needs have been satisfied or as opportunities arise. Locations for implementation are prioritized
 24 based on NPS pollutant load reduction potential, maintenance requirements, number of practices
 25 and frequency required for load reduction, and relative cost. In addition, practices that address
 26 pollutant control on lands that drain into the ocean at or to the north of Kahekili Beach Park are
 27 considered high priority. Corals offshore of Kahekili have been impacted by land based pollutants,
 28 causing coral dieback and reducing coral cover. The ocean currents north of Kahekili flow to the
 29 south, meaning that pollutants discharged into the ocean to the north can be carried towards
 30 Kahekili. Reduction of pollutant loads is a function of both the types and number of management
 31 practices installed.

32 Fallow seed corn, pineapple and sugar cane fields, and access roads within the fields are the
 33 primary targets of management efforts within the Agricultural Unit. Fine sediment generated off
 34 these areas at accelerated rates of erosion is a significant NPS pollutant in the region. Honokōwai
 35 Watershed is the highest priority for road network and field repairs since the streams and gulches
 36 draining the watershed enter the ocean near the coral reefs by Kahekili Beach Park. Application of
 37 chemicals such as fertilizers and pesticides to maximize crop production and control pest and plant
 38 diseases is another source of land-based pollutants. The amount of legacy contaminants in the soil
 39 and groundwater is unknown, as is how much is transported to the ocean via surface overland flow
 40 and groundwater discharges.¹ Management practices recommended to reduce generation and treat

¹ Pollutants associated with the plantation era, and now the former seed corn cultivation, are referred to as legacy pollutants.

1 pollutants from agricultural lands include erosion controls, fertilizer management plans, and post
2 fire rehabilitation plans.

3 Management efforts in the Urban Unit are primarily associated with the disposal of treated effluent
4 from the Lahaina WWRF into injection wells, transport of pollutants off landscaped and impervious
5 surfaces, and localized areas of erosion. The disposal of treated effluent from the WWRF into
6 injection wells is a water quality issue that has been the focus of several studies, discussions, and
7 working group efforts. The treated effluent is hydrologically connected to ocean waters and
8 transports various chemicals including Nitrogen and Phosphorus to the ocean via groundwater that
9 is discharged along the shoreline. The volume of effluent injected into the ground can be reduced by
10 increasing the volume of R-1 water used for irrigation and other approved applications. To do this,
11 the number of end users of R-1 water needs to be increased, which requires expansion of pipelines
12 and other infrastructure. The expansion is costly and will require numerous years to complete.
13 Although 100 percent reuse is a goal, it is likely that injection wells will be needed in some capacity.

14 Nutrient and other chemical inputs from fertilizer, pesticides, and irrigation activities on resort, golf
15 course, residential and commercial properties can be conveyed via overland or groundwater flow
16 into the coastal environment. Other land-based pollutants from vehicles, debris disposal, exposed
17 soil surfaces, and other sources that collect on the impervious surfaces are carried in stormwater
18 runoff and routed into the ocean via diffuse flow paths and in the storm sewer systems. These
19 pollutant discharges can be abated using soft management practices such as bioretention cells (rain
20 gardens) or vegetated swales that encourage infiltration of runoff onsite. Hard practices, including
21 retrofits to the separate storm sewer system (S4) such as catch basin filter inserts or baffle boxes
22 can be used to reduce pollutant transport once water enters the conveyance systems. Locations
23 recommended for installation of management practices are shown on Figure 4 and Figure 5.

24 Major sources of NPS pollution can be remediated through the implementation of management
25 practices. Targeting priority areas and sites, and applying appropriate strategies is expected to
26 decrease generation and transport of land-based pollutants that reach the ocean. Problem areas
27 that are contributing the most sediment should, to the extent possible, be targeted first to reduce
28 sediment transport to the ocean in a timely manner. Table ES-1 illustrates the major NPS pollutant
29 sources in order of priority for remediation. The highest ranking solutions are considered to have
30 the most effective long-term benefit to the coral reef system and coastal waterbodies. Some
31 solutions involve additional studies or designs to target specific management practices.

32 Section 4, *Evaluation and Monitoring*, provides programmatic evaluation criteria and describes four
33 types of monitoring necessary to track management practices: trend, implementation, baseline, and
34 effectiveness. Qualitative and quantitative information about the management practices and the
35 condition of the coral reef ecosystem helps determine their effectiveness and apply the findings to
36 other watersheds. Milestones should be set to track implementation on a programmatic level as
37 well as the pollutant reductions being achieved and the affected change in the health of the coral
38 reef ecosystem. The WHWMP includes recommendations for monitoring and identifies site-based
39 effectiveness monitoring for the management practices. Long-term trend monitoring of the health
40 of the coral reef ecosystem will also provide information that can be correlated to implementing

1 solutions to reduce land-based NPS pollutants. Baseline monitoring of corals using toxicologic
2 analysis to determine what chemicals have and are contributing to coral decline is recommended.

3 Success of the WHWMP is dependent on stakeholder awareness and involvement. Section 5,
4 *Education and Outreach*, provides details on recommended current and planned activities to engage
5 the local community in efforts to reduce NPS pollution. These strategies, some of which are already
6 underway, are aligned with the larger West Maui R2R Initiative. Future iterations of the WHWMP
7 should incorporate elements of Hawaiian culture (e.g. traditional Hawaiian land divisions and place
8 names, pre-Western contact land use management practices, and traditional ecological knowledge)
9 into the planning framework. The WHWMP would benefit from incorporation of this information in
10 future updates or addendums. Planning processes that use the WHWMP as a template should
11 consider including this information from the beginning.

12 Watershed management planning is inherently adaptive, with managers continually reassessing
13 both the implementation process and the effectiveness of the chosen strategies in order to ensure
14 progress is being made toward desired future conditions. The WHWMP should be evaluated
15 annually to document accomplishments and prioritize upcoming actions based on current
16 knowledge. Implementation of the solutions recommended in the WHWMP, per the identified
17 priorities, is crucial to reducing the generation and transport of sediments and other NPS
18 pollutants. This will result in improved water quality and ecosystem health within the watersheds
19 and the nearshore coastal waters. A comprehensive monitoring program should be implemented to
20 measure the progress towards improved water quality and coral reef health over time. The
21 WHWMP can also be used as a template for other watersheds in the West Maui area to create a
22 broader regional approach to NPS pollution control aimed at improving coral reef health.

23

1 **Table ES-1. Priority Projects and Management Practices to Address NPS Pollution in Wahikuli and Honokōwai Watersheds**
 2 (in order of implementation priority, from top to bottom)

NPS Pollutant Source and Associated Projects and Management Practices	Responsible Entity for Implementation and Maintenance	Implementation Cost (estimates)	Desired Implementation Timeframe	WHWMP Reference Section and Related Information Sources
Agricultural Access Roads				
Road and Trail Inventory Assessment and Proposed Practices <ul style="list-style-type: none"> - Road Drainage Improvements - Road Realignment and Rebuilding - Sediment Retention Basin 	<ul style="list-style-type: none"> • Land Owner (ML&P, KLMC, GFG, and DHHL) • NRCS/SWCD (technical assistance when requested) 	For all subwatersheds: <ul style="list-style-type: none"> • Inventory / Assessment: \$49k • Installation: \$268k 	<ul style="list-style-type: none"> • Phased inventory assessment (2012-2014) • Phased implementation (2013-2017) 	<ul style="list-style-type: none"> • Section 3.1 • Road Drainage Improvements (App B.3) • Road Realignment and Rebuilding (App B.4) • Sediment Retention Basin (App B.5)
Fallow Agricultural Fields				
Agricultural Field Inventory Assessment and Proposed Practices <ul style="list-style-type: none"> - Conservation Cover - Sediment Retention Basin - Vegetated Filter Strip 	<ul style="list-style-type: none"> • Land Owner (ML&P, KLMC, GFG, and DHHL) • NRCS/SWCD (technical assistance when requested) 	For all subwatersheds: <ul style="list-style-type: none"> • Inventory / Assessment: \$43k • Installation: variable 	<ul style="list-style-type: none"> • Phased inventory assessment complete by end of 2014 	<ul style="list-style-type: none"> • Section 3.2 • Conservation Cover • Sediment Retention Basin (App B.5) • Vegetated Filter Strip (App B.6)
WWRF				
WWRF Alternate Disposal: Increase Production and Reuse of R-1 Water	<ul style="list-style-type: none"> • County of Maui and/or potential users (resorts) • Coral Reef Alliance is working with resorts on R-1 use (NFWF funding) 	<ul style="list-style-type: none"> • Tens of millions of dollars, depending on expansion phase 	<ul style="list-style-type: none"> • Initial Phase: 2014 • Subsequent Phases: 2020 	<ul style="list-style-type: none"> • County of Maui plan • Section 3.3
Dam and Gulch Conveyance				
Engineering Analysis and Development of Retrofit Designs: Honokowai Structure #8 <ul style="list-style-type: none"> - Dam Debris Retrofit - Baffle Box - Natural/Native/Drought Resistant Vegetation - Riprap 	<ul style="list-style-type: none"> • County of Maui Department of Public Works • NRCS (design concurrence) 	<ul style="list-style-type: none"> • Design: \$85k • Construction: To be determined 	<ul style="list-style-type: none"> • Design complete by 2015 	<ul style="list-style-type: none"> • Section 3.4 • Dam Debris Retrofit • Baffle Box (App B.1) • Natural/Native/Drought Resistant Vegetation (App C.8) • Riprap (App C.11)

NPS Pollutant Source and Associated Projects and Management Practices	Responsible Entity for Implementation and Maintenance	Implementation Cost (estimates)	Desired Implementation Timeframe	WHWMP Reference Section and Related Information Sources
Engineering Analysis and Development of Stabilization Designs: Wahikuli Gulch <ul style="list-style-type: none"> - Erosion Control Blanket / Turf Reinforcement Mat - Riprap 	<ul style="list-style-type: none"> • County of Maui Department of Public Works Highways and Engineering Division and Planning Department • KOA 	<ul style="list-style-type: none"> • Design: \$96k • Construction: \$238k 	<ul style="list-style-type: none"> • Design complete by 2016 	<ul style="list-style-type: none"> • Section 3.5 • Erosion Control Blanket / Turf Reinforcement Mat (App C.3) • Riprap (App C.11)
Vegetation Management				
Fertilizer Management Plan	<ul style="list-style-type: none"> • KLMC, Kaanapali Coffee Company (Coffee Farm) • KOA (Ka'anapali Resorts) • Property owners and neighborhood associations 	<ul style="list-style-type: none"> • \$3k (10 acre resort) 	<ul style="list-style-type: none"> • Plans for Agricultural Areas complete by 2015 • Plans for Urban Areas complete by 2016 	<ul style="list-style-type: none"> • Section 3.6 • This is a separate plan
Wildfire (Potential)				
Burn Area Emergency Response Plan	<ul style="list-style-type: none"> • Land owners in the Agricultural and Conservation Management Units (ML&P, KLMC, DHHL, GFG, State) • WMMWP • West Maui Fire Task Force • Hawaii Wildfire Organization 	<ul style="list-style-type: none"> • \$50k 	<ul style="list-style-type: none"> • Plan complete by 2014 	<ul style="list-style-type: none"> • Section 3.7 • This is a separate plan
Urban Pollutants				
Baffle Box	<ul style="list-style-type: none"> • County of Maui Department of Public Works 	<ul style="list-style-type: none"> • \$90k 	<ul style="list-style-type: none"> • Construction complete by end of 2015 	<ul style="list-style-type: none"> • Section 3.8 and Appendix B.1 • Specific location: Honokōwai Beach Park
Bioretention Cell (Rain garden)	<ul style="list-style-type: none"> • County of Maui Department of Parks and Recreation • Resorts 	<ul style="list-style-type: none"> • \$20-30k 	<ul style="list-style-type: none"> • Construction complete by end of 2015 	<ul style="list-style-type: none"> • Section 3.9 and Appendix B.2 • Specific locations: Wahikuli Wayside Beach Park and Pōhaku Beach Park

Table of Contents

1		
2	Executive Summary.....	i
3	Table of Contents.....	vii
4	List of Tables.....	ix
5	List of Figures.....	ix
6	Acronyms.....	x
7	1. Introduction.....	1
8	1.1 Vision and Goals.....	1
9	1.2 NPS Pollution Management Hierarchy.....	2
10	1.3 Pollutants Types Generated by Management Unit.....	2
11	1.4 Targeting Pollution Hotspots.....	3
12	2. Implementation Strategies.....	5
13	2.1 Implementing A Watershed Management Plan.....	5
14	2.1.1 Responsible Entities.....	5
15	2.1.2 Legal Requirements.....	6
16	2.2 Financing Implementation.....	7
17	2.2.1 Financial Resources.....	7
18	2.2.2 Implementation Costs.....	9
19	2.3 Technical Implementation of Management Practices.....	9
20	2.3.1 Data and Analysis Recommendations For Design of Management Practices.....	10
21	2.3.2 Technical Resources.....	10
22	2.4 Adaptive Management.....	10
23	3. Pollution Control Strategies.....	12
24	3.1 Access Road and Trail Inventory Assessment and Proposed Practices.....	15
25	3.2 Agricultural Field Inventory Assessment and Proposed Practices.....	24
26	3.3 WWRF Alternate Disposal: Increase Production and Reuse of R-1 Water.....	30
27	3.4 Honokōwai Structure #8: Dam Analysis and Solution Design Development.....	37
28	3.5 Wahikuli Gulch: Gulch Analysis and Solution Design Development.....	40
29	3.6 Fertilizer Management Plan.....	44
30	3.7 Burn Area Emergency Rehabilitation Plan.....	47
31	3.8 Baffle Box.....	49
32	3.9 Bioretention Cells for Treatment of Surface Runoff.....	53
33	3.10 Low-Impact Development Strategies for Future Development.....	59
34	4. Evaluation and Monitoring.....	61
35	4.1 Measuring Effectiveness of Watershed Management Planning.....	61
36	4.1.1 Program Implementation.....	61
37	4.1.2 Management Practice Performance.....	61
38	4.1.3 Pollution Reduction Targets.....	62
39	4.1.4 Performance Metrics.....	62
40	4.2 Monitoring Logistics.....	63
41	4.2.1 Drivers for Monitoring.....	63
42	4.2.2 Monitoring and Data Collection Responsibility.....	64
43	4.2.3 Data Collection, Storage, and Reporting.....	64
44	4.3 Monitoring in Wahikuli and Honokōwai Watersheds.....	65

1 4.3.1 Trend Monitoring 66

2 4.3.2 Baseline Monitoring of Environmental Conditions 66

3 4.3.3 Implementation Monitoring..... 67

4 4.3.4 Effectiveness Monitoring of Management Practices..... 68

5 4.3.5 Additional Studies to Fill Data Gaps..... 68

6 4.4 Summary of Evaluation and Monitoring Recommendations 69

7 5. Education and Outreach..... 70

8 5.1 Build Public Awareness and Support..... 70

9 5.1.1 Key Themes and Messages 71

10 5.2 Organizational Support for Implementation and Outreach..... 72

11 5.2.1 Watershed Coordinator 72

12 5.2.2 FAST and Other Agency Support..... 73

13 5.2.3 West Maui R2R Working Group 73

14 5.2.4 West Maui R2R Hui 73

15 5.3 Engage the Community..... 73

16 5.3.1 Outreach Tools and Methods..... 74

17 5.3.2 Suggested Educational Topics for Increasing Community Watershed Stewardship ... 76

18 5.4 Watershed Management Activities 77

19 5.4.1 Examples of Ongoing Efforts by the West Maui R2R Hui..... 77

20 5.4.2 Educational Opportunity: Pilot Projects 79

21 5.5 Change Policy..... 79

22 5.5.1 Proposed County of Maui Rules for Stormwater Treatment..... 79

23 5.5.2 Recommendations for Future Development..... 80

24 6. Conclusions 81

25 Appendix A. NPS Pollution Management Hierarchy A-1

26 Appendix B. Priority Management Practices B-1

27 Appendix C. Secondary Management Practices C-1

28 Appendix D. Designing a Monitoring Program D-1

29 Appendix E. Information Cited..... E-1

30

1 **List of Tables**

2 Table ES-1. Priority Projects and Management Practices to Address NPS Pollution in Wahikuli and
 3 Honokōwai Watersheds.....v
 4 Table 1. NPS Pollutant Generation Types for Management Units..... 3
 5 Table 2. Hotspots and Relative Priority for Implementation 4
 6 Table 3. Summary of Management Practices 13
 7 Table 4. Priority Sub-Watersheds for Road Drainage Improvements..... 18
 8 Table 5. Estimated Cost for Road Drainage Improvements..... 20
 9 Table 6. Cost for Improvement of Example Road.....22
 10 Table 7. Acres of Fallow Fields by Crop Types and Subwatershed..... 24
 11 Table 8. Priority Sub-Watersheds for Field Improvements.....27
 12 Table 9. Estimated Cost for Agricultural Field Inventory and Assessment.....29
 13 Table 10. Cost Estimate for Developing Honokōwai Structure #8 Detailed Engineering Design..... 39
 14 Table 11. Cost Estimate for Developing Wahikuli Gulch Stabilization Detailed Engineering Design.43
 15 Table 12. Estimated Construction Cost for Wahikuli Gulch Stabilization 43
 16 Table 13. Baffle Box Pollutant Removal Efficiencies.....51
 17 Table 14. Example Metrics for Evaluating Progress towards Meeting Watershed Goals..... 62
 18 Table 15. General Characteristics of Monitoring Types 65
 19 Table 16. Baseline Monitoring Parameters 67
 20 Table 17. Evaluation and Monitoring Recommendations 69
 21 Table 18. Potential Projects for Community Members..... 74
 22

23 **List of Figures**

24 Figure 1. Priority Sites: Roads and Trails 17
 25 Figure 2. Example: Conceptual Design for Road Repairs..... 23
 26 Figure 3. Priority Sites: Agricultural Fields 26
 27 Figure 4. Wahikuli Urban District: Selected Management Practice Locations..... 35
 28 Figure 5. Honokōwai Urban District: Selected Management Practice Locations..... 36
 29 Figure 6. Conceptual Design for Wahikuli Gulch Stabilization 42
 30 Figure 7. Conceptual Design for Rain Garden at Wahikuli Wayside Park..... 56
 31

1 **Acronyms**

2	BAER	Burn Area Emergency Rehabilitation
3	BMP	Best Management Practice
4	CAP	Conservation Action Plan
5	CORAL	Coral Reef Alliance
6	CWA	Clean Water Act
7	CWB	Clean Water Branch
8	CWG	Community Working Group
9	CWSRF	Clean Water State Revolving Fund
10	CZARA	Coastal Zone Act Reauthorization Amendments
11	DAR	Division of Aquatic Resources
12	DBEDT	Department of Business, Economic Development and Tourism
13	DCIA	Directly Connected Impervious Areas
14	DHHL	Department of Hawaiian Home Lands
15	DLNR	Department of Land and Natural Resources
16	DOH	Department of Health
17	EPA	Environmental Protection Agency
18	FAST	Funding and Agency Support Team
19	GFG	General Finance Group
20	HRS	Hawai'i Revised Statutes
21	KLMC	Kā'anapali Land Management Corporation
22	LBSP	Land-Based Sources of Pollution
23	LID	Low Impact Development
24	MG	Million Gallons
25	ML&P	Maui Land & Pineapple, Inc.
26	msl	Mean Sea Level
27	NEPA	National Environmental Policy Act
28	NHPA	National Historic Preservation Act
29	NOAA	National Oceanic and Atmospheric Administration
30	NPDES	National Pollutant Discharge Elimination System
31	NPS	Non-point Source
32	NRCS	Natural Resources Conservation Service
33	O&M	Operations and Maintenance
34	QA/QC	Quality Assurance and Quality Control
35	QAPP	Quality Assurance Project Plan
36	R2R	Ridge to Reef
37	RUSLE2	Revised Universal Soil Loss Equation
38	S4	Separate Storm Sewer System
39	TDS	Total Dissolved Solids
40	TMDL	Total Daily Maximum Load
41	TSS	Total Suspended Solids
42	USACE	U.S. Army Corps of Engineers
43	WHWMP	Wahikuli-Honokōwai Watershed Management Plan
44	WMMWP	West Maui Mountains Watershed Partnership
45	WMP	Watershed Management Plan
46	WMSWCD	West Maui Soil and Water Conservation District
47	WWRF	Wastewater Reclamation Facility
48		

1. Introduction

The Wahikuli-Honokōwai Watershed Management Plan (WHWMP) was developed to address the impacts of land-based pollutants on coral reefs for two West Maui watersheds, Wahikuli and Honokōwai. The WHWMP identifies land-based sources of pollutants (LBSP) and presents actions to remediate them to reduce stress on the reefs.

In *Volume 1: Watershed Characterization*, the pollutants and their sources from Conservation, Agricultural, and Urban lands were identified. *Volume 2: Strategies and Implementation* identifies specific management practices to reduce or prevent NPS pollutant generation, or treat polluted runoff. It also outlines strategies to insure successful implementation, evaluation, and community engagement. Together, Volumes 1 and 2 of the WHWMP address the key components of a watershed-based plan as defined by the EPA (Box 1).

Box 1. EPA’s Nine Key Components for Watershed-Based Plans

1. Identification of causes of impairment and pollutant sources or groups of similar sources that need to be controlled to achieve needed load reductions, and any other goals identified in the watershed plan.
2. An estimate of the load reductions expected from management measures.
3. A description of the nonpoint source management measures that will need to be implemented to achieve load reductions, and a description of the critical areas in which those measures will be needed to implement this plan.
4. Estimate of the amounts of technical and financial assistance needed, associated costs, and/or the sources and authorities that will be relied upon to implement this plan.
5. An information and education component used to enhance public understanding of the project and encourage their early and continued participation in selecting, designing, and implementing the nonpoint source management measures that will be implemented.
6. Schedule for implementing the nonpoint source management measures identified in this plan that is reasonably expeditious.
7. A description of interim measurable milestones for determining whether nonpoint source management measures or other control actions are being implemented.
8. A set of criteria that can be used to determine whether loading reductions are being achieved over time and substantial progress is being made toward attaining water quality standards.
9. A monitoring component to evaluate the effectiveness of the implementation efforts over time, measured against the criteria established.

1.1 Vision and Goals

Vision: Healthy and resilient coral reefs that support marine life and sustainable human use as a result of active watershed stewardship by businesses and the public, reducing land-based pollution in Kā’anapali from mauka to makai.

Volume 1 of the WHWMP characterized the Wahikuli and Honokōwai Watersheds, including identifying pollutant types and sources. A clear vision and set of goals provides the context in Volume 2 for identifying management strategies to reduce LBSP in the Agricultural and Urban areas.² The vision is aligned with the overarching goal of the West Maui R2R Initiative to “Restore and enhance the health and resiliency of West Maui coral reefs and nearshore waters through the

² Key to achieving the vision will be coordination with the WMP that the West Maui Mountains Watershed Partnership is developing for the Conservation District lands.

reduction of land-based pollution threats from the summit of Pu’u Kukui to the outer reef.” Each goal is supported by management strategies, implementation of which will help achieve the goal.

Box 2. WHWMP Goals

1. Measurably reduce rates of erosion and sediment loads generated on dirt roads, fields, and along waterways in the agricultural and urban areas of Wahikuli and Honokōwai Watersheds and carried to the coral reefs by 2017.
2. Measurably reduce fertilizer loss and nutrient loads generated from residential and resort properties and agricultural fields of Wahikuli and Honokōwai Watersheds and carried to coral reefs by 2017.
3. By maximizing reuse, decrease the amount of treated wastewater effluent from the Lahaina Wastewater Reclamation Facility injected into the ground and transported to the ocean by 2023.
4. Provide effective guidance to ensure implementation and long-term success of watershed management efforts in Wahikuli and Honokōwai Watersheds by 2014.
5. Increase education, understanding, and participation by both residents and visitors regarding watersheds, non-point source pollution, and coral reef health in Wahikuli and Honokōwai Watersheds by 2017.

1.2 NPS Pollution Management Hierarchy

Box 3 summarizes the hierarchical set of terms used throughout this document to categorize and discuss management of NPS pollutants: management unit, management measure, and management practice. Additional details are provided in Appendix A.

Box 3. NPS Pollution Management Hierarchy

- Management Unit.** The geographical area, land use, or specific source of pollutant input to which a given set of management measures apply. In this WHWMP, management units are the same as the State Land Use Districts (Conservation, Agricultural, or Urban).
- Management Measure.** Economically achievable measure to control the addition of NPS pollutants through the best available practices, technologies, processes, siting criteria, operating methods, or other alternatives. Examples of management measures include: erosion and sediment control; nutrient; and irrigation. The same measure can occur in multiple management units.
- Management Practice.** An individual action (e.g. treatment, strategy, plan) to lessen generation and transport of NPS pollutants. One or more management practices are implemented to satisfy a management measure. Examples of management practices include: installation of a sediment retention basin and creation of a fertilizer management plan. The same practice can occur in multiple management units.

1.3 Pollutants Types Generated by Management Unit

There are several categories of NPS pollutants generated within the project area: sediment; nutrients; organics; bacteria; debris/litter; and hydrocarbons (Table 1). Their presence within each of the Units depends on the activities taking place. The land-based pollutants of primary concern within the watersheds are sediments and nutrients (Nitrogen and Phosphorus) (*Volume 1: Watershed Characterization*, Section 2.1.3). These pollutants are generated across all areas of the watersheds both from natural processes (background) and human uses (accelerated). Additional details on the development of the priority ranking system for pollutant types, sources, hotspots, and areas of concern is presented in *Volume 1: Watershed Characterization*, Section 6.

1
2**Table 1. NPS Pollutant Generation Types for Management Units**

Pollutant Type ³	Management Unit		
	Conservation	Agricultural	Urban
Sediment	✓	✓	✓
Nutrients	✓	✓	✓
Organics		✓	✓
Bacteria	✓	✓	✓
Debris/Litter	✓	✓	✓
Hydrocarbons		✓	✓

3 Sediments were identified by coral reef scientists as a high priority NPS pollutant in the Wahikuli
4 and Honokōwai Watersheds. Sediments are the product of soil erosion off land surfaces and along
5 streams and gulches as well as rock and soil that fall into or near waterways via landslides. Fine
6 sediments carried in surface water runoff often carry other pollutants attached to sediment
7 particles.⁴ Consequently, lowering rates of erosion and sediment loads often results in reducing
8 loads of other pollutants. A combination of field observations, stakeholder communications,
9 calculations to generate estimates of soil loss, and analysis of high resolution aerial photography
10 was employed to determine areas with the greatest extent of active and potential erosion within the
11 watersheds.

12 Nutrients, primarily Nitrogen and Phosphorus, were identified as priority NPS pollutant to be
13 impairing ocean water and adversely impacting the coral reef and marine ecosystem. However,
14 there are many unknowns about nutrient sources and the transport and fate of nutrients within
15 Wahikuli and Honokōwai Watersheds. Unlike sediments, which are transported via surface flow,
16 nutrients can be transported in both surface water and groundwater, making quantification of their
17 relative and absolute loads challenging. In addition, it is difficult to partition how much of the total
18 load of nutrients reaching the ocean comes from various land uses. A portion of the nutrients
19 transported off the watershed may be sourced to fertilizers applied to fields during historic and
20 current agricultural activities as well as from areas currently landscaped. Regardless of the source,
21 or specific details of transport and fate, nutrients concentrations have been measured in coastal
22 waters that routinely exceed the water quality standards and are impairing ocean water quality.

23 **1.4 Targeting Pollution Hotspots**

24 The ranking system for NPS pollutant hotspots discussed in *Volume 1: Watershed Characterization*,
25 Section 6 was developed to determine low, medium, or high priority pollutant locations to be
26 addressed with practices. Table 2 summarizes the Agricultural and Urban District hotspots, their
27 relative priority for addressing through remediation, and targeted pollutants.

28 The highest priority pollution hotspots are areas of exposed soil that are eroding at accelerated
29 rates, or have high erosion potential due to anthropogenic land alteration, activities, and land use.
30 These hotspots usually lack management practices to trap or filter dislodged sediments on the
31 watershed. When transported in concentrated stormwater runoff, soils have a high likelihood for

³ Pollutant types are described in detail in *Volume 1: Watershed Characterization*, Table 16.

⁴ Other pollutants are attached to sediment particles via adsorption and absorption.

1 rapidly entering stream channels and the coral reef environment. Nutrients and other pollutants
 2 that can chemically and physically bind to soil particles can also migrate easily through the
 3 environment. The highest priority hotspots of nutrient generation are those areas that have
 4 potential for or readily introduce high nutrient loadings into the coral reef environment, either
 5 through surface water or groundwater transport.

6 **Table 2. Hotspots and Relative Priority for Implementation**

Hotspot	Relative Priority	Targeted Pollutant(s)
Agricultural District		
Agriculture Roads (Pineapple fields): Steep segments, running perpendicular to contours, segments along top of gulches showing evidence of heavy erosion	High	Sediment
Agriculture Roads (Seed corn fields): Steep segments, running perpendicular to contours, showing evidence of heavy erosion	High	Sediment
Pineapple field terrace outlets and access road outlets into stream and gulch channels: at various locations in and along fallow fields	High	Sediment
Fallow bare seed corn fields ⁵ (all)	High	Sediment, Nutrients, Organics
Pineapple field terraces: Primarily in lower fields north of Honokōwai Stream	Medium	Sediment
County of Maui maintained earthen dams and desilting basins	Medium	Sediment, Debris/Litter
Unmaintained field access roads (aligned with contours, showing moderate erosion, all regions)	Medium	Sediment
Eroding access road shoulders (steep segments aligned with contour)	Medium	Sediment
Active and fallow coffee field terraces: Location (all)	Low	Sediment
Māhinahina and Honokōwai Streams, other natural stream channels	Low	Sediment, Nutrients, Debris/Litter, Bacteria
Fallow pineapple and sugarcane fields, active and fallow coffee fields (all)	Low	Sediment
Urban District		
WWRF treated effluent disposal into injection wells	High	Nutrients, other
Unstabilized residential and commercial construction sites	High	Sediment
Unstabilized developed lands (cemeteries, beach park erosion)	High	Sediment
Wahikuli Gulch and other eroding natural stream channels	High	Sediment, Nutrients, Debris/Litter, Bacteria
Outdoor vehicle washing	Medium	Hydrocarbons
Impervious parking lot and roadway surfaces	Medium	Hydrocarbons
Concrete lined stream channels / basin outlet channels	Low	Debris/Litter, Bacteria
Kapalua-West Maui Airport	Low	Hydrocarbons
Kā'anapali Golf Course and other stabilized and landscaped areas	Low	Nutrients

7

⁵ Subsequent to preparing WHWMP Volume 1, seed corn cultivation ceased. Seed corn fields are now fallow and grasses and other alien plants are growing in. Cover density and plant vigor on the fallow seed corn fields varies.

2. Implementation Strategies

Identifying key implementation strategies will ensure that the management practices identified in the WHWMP are developed and implemented with a solid foundation and oversight aimed at measureable reductions in pollutant loads. Management plan implementation depends largely on community and stakeholder support and coordination for success. Strategies presented in this section are aimed at meeting Goal 4: *Provide effective guidance to ensure implementation and long-term success of watershed management efforts in Wahikuli and Honokōwai Watersheds by 2014.* (Box 2). Implementation strategies must consider both overall WMP implementation (Section 2) and specific projects or management practices (Section 3).

2.1 Implementing A Watershed Management Plan

2.1.1 Responsible Entities

An important component of an implementation strategy is identification of the entities responsible for implementation. The WHWMP is a component of the West Maui R2R Initiative, which is an all encompassing initiative to address impacts to coral reefs in West Maui. The goal of the West Maui R2R Initiative is to “restore and enhance the health and resiliency of West Maui coral reefs and nearshore waters through the reduction of land-based pollution threats from the summit of Pu‘u Kukui to the outer reef.” The West Maui R2R Initiative is being developed with USACE and DLNR funding, but includes all partner initiatives and actions. Coordinated efforts for studies, implementation, and monitoring are taking place as part of this initiative. The project area is a priority site of the Hawai‘i Coral Reef Strategy, an effort led by DLNR-DAR. As a priority site, DLNR-DAR has responsibility for overall coordination of strategies for reducing NPS pollution in the Kā‘anapali Region.

Local expertise is being provided by the West Maui Watershed and Coastal Coordinator and the West Maui R2R Working Group. The Coordinator is an on-the-ground resource and facilitator of watershed planning and implementation efforts in the West Maui region with a focus on building community networks and educating stakeholders (Section 5.2.1). The Working Group is comprised of representatives who are actively engaged in the project area and represent the diversity of uses and interests in the Kā‘anapali Region (Section 5.2.2). It functions to provide feedback, propose and champion implementation projects, and assist in the dissemination of information back to the respective interest groups.

Recommended management practices can be required under a regulatory program or implemented voluntarily. Often, overall implementation of a WMP is accomplished through the joint efforts of private and public entities. Responsibility for implementing management practices will often fall on landowners of the parcel or site where the practices will be installed. In many cases there will be more than one entity involved, particular at different stages of the process, so ongoing coordination will be needed and a lead entity needs to be identified. Entities that may directly or indirectly implement the recommended management practices include, but are not limited to: USACE, DLNR, Hawai‘i Department of Transportation, Maui County, commercial businesses, private land owners, and community groups/volunteers.

1 **2.1.2 Legal Requirements**

2 As a planning document, the WHWMP is not subject to evaluation under the National
 3 Environmental Policy Act (NEPA), Hawai'i Revised Statutes (HRS) Chapter 343 (Environmental
 4 Impact Statements), the National Historic Preservation Act (NHPA) (Section 106), or HRS Chapter
 5 6E (Historic Preservation) (Box 4). Consultation with the public is being conducted as part of the
 6 watershed planning process (Box 1).

7 **Box 4. When Do Federal and State Statutes Apply?**

8 **NEPA** establishes national environmental policy and goals for the protection, maintenance, and enhancement of the
 9 environment and it provides a process for implementing these goals within Federal agencies. NEPA requires Federal
 10 agencies to consider the potential environmental consequences of their proposals, to consult with other interested
 11 agencies, to document the analysis, and to make this information available to the public for comment before the
 12 implementation of the proposals. NEPA is only applicable to Federal actions, including projects and programs entirely or
 13 partially financed by Federal agencies and that require a Federal permit or other regulatory decision.

14 **HRS Chapter 343** requires an environmental assessment for actions that⁶: Propose the use of state or county lands or
 15 the use of state or county funds, other than funds to be used for feasibility or planning studies for possible future
 16 programs or projects which the agency has not approved, adopted, or funded, or funds to be used for the acquisition of
 17 unimproved real property; provided that the agency shall consider environmental factors and available alternatives in its
 18 feasibility or planning studies; Propose any use within any land classified as conservation district by the state land use
 19 commission under Chapter 205; Propose any use within the shoreline area as defined in Section 205A-41; Propose any
 20 use within any historic site as designated in the National Register or Hawai'i Register as provided for in the Historic
 21 Preservation Act of 1966, Public Law 89-665, or Chapter 6E; Propose any amendments to existing county general plans
 22 where such amendment would result in designations other than agriculture, conservation, or preservation, except
 23 actions proposing any new county general plan or amendments to any existing county general plan initiated by a county;
 24 and Propose any reclassification of any land classified as conservation district by the state land use commission under
 25 Chapter 205.

26 **NHPA Section 106** requires each Federal agency to identify and assess the effects of its actions on historic resources.⁷
 27 The responsible Federal agency must consult with appropriate State and local officials, Indian tribes, applicants for
 28 Federal assistance, and members of the public and consider their views and concerns about historic preservation issues
 29 when making final project decisions. Section 106 applies when two thresholds are met: there is a Federal or federally
 30 licensed action, including grants, licenses, and permits, and that action has the potential to affect properties listed in or
 31 eligible for listing in the National Register of Historic Places.

32 **HRS Chapter 6E** provides guidance on conserving and developing the historic and cultural property within the State for
 33 the public good. §6E-8 requires the review of effect of proposed state projects on historic properties, aviation artifacts, or
 34 burial sites, consistent with §6E-43, especially those listed on the Hawaii register of historic places. Before any agency
 35 or officer of the State or its political subdivisions commences any project which may affect these items, the State Historic
 36 Preservation Division must review of the effect of the proposed project. Similarly, §6E-10 requires private landowners to
 37 provide an opportunity for review of any construction, alteration, disposition or improvement of any nature, by, for, or
 38 permitted that will affect an historic property on the Hawai'i Register of historic places. The proposed project shall not be
 39 commenced, or in the event it has already begun, continued, until the department shall have given its concurrence.⁸

40 A review of laws, ordinances, government programs, and plans pertaining to NPS and point source
 41 pollutants was conducted to determine if the recommended practices are required to comply with a
 42 rule or law and/or program or plan (*Volume 1: Watershed Characterization, Section 2.2*). For many
 43 locations identified in the WHWMP where practices should be installed there are no regulations
 44 that require installation or implementation. However, installation of the recommended practices is
 45 compatible with, and often supported by programs, plans, and regulations addressing and
 46 governing NPS pollution control.

⁶ http://www.hawaii.edu/ohelo/statutes/HRS343/HRS_343-5.htm

⁷ <http://www.achp.gov/nhpp.html>

⁸ http://www.capitol.hawaii.gov/hrscurrent/Vol01_Ch0001-0042F/HRS0006E/

1 In some instances implementation of a management practice will require permits and/or
 2 compliance with Federal and State laws designed to protect natural and cultural resources
 3 (Appendix A, Table A.1). These may include securing a CWA Section 404 (*Discharge Dredged or Fill*
 4 *Material into Waters of the US*) Permit from USACE; a CWA Section 401 Permit (Water Quality
 5 Certification) or CWA Section 402 Individual Permit (*National Pollutant Discharge Elimination*
 6 *System* (NPDES)) from Department of Health Clean Water Branch (DOH-CWB); a County of Maui
 7 Grading or Grubbing Permit; or a Special Management Area Use Permit for construction from Maui
 8 County.

9 **2.2 Financing Implementation**

10 Implementing a WMP requires funding for programmatic elements, installation of management
 11 practices, monitoring, and education and outreach.

12 **2.2.1 Financial Resources**

13 Funding for watershed management planning efforts (i.e. on-going planning, management practice
 14 implementation, monitoring, education, and outreach) can come from a range of sources including
 15 Federal, State, local and private entities. Funding mechanisms will include contracts, private funds,
 16 community grants, cost-share agreements, and volunteer efforts.

17 The coral reef ecosystem along the West Maui region is a priority management area for the Hawai'i
 18 Coral Reef Strategy. Planning for the watershed areas is encompassed by West Maui R2R Initiative
 19 (Section 2.1.1). The West Maui R2R Funding and Agency Support Team (FAST) is the interagency
 20 team sponsoring the West Maui R2R Initiative. The West Maui R2R FAST is comprised of agencies
 21 and organizations specifically funding the initiative including DLNR, DOH, USACE, NOAA, EPA,
 22 Natural Resources Conservation Service (NRCS), and National Fish and Wildlife Foundation. An
 23 “umbrella” watershed plan, funded by DLNR and USACE, to support the West Maui R2R Initiative
 24 will build off of the WHWMP. It is scheduled to begin in Fall 2012 and be completed by Fall 2015. A
 25 tiered process will be developed to implement actions during the plan development as well as after
 26 the plan is completed. Implementation will be done by members of the FAST as well as partner
 27 organizations and stakeholders participating in the West Maui R2R Hui, a collaborative partnership
 28 of county, State and Federal agencies, academia, non-governmental organizations, community
 29 groups, and stakeholders.

30 Specific funding resources that have already been identified to support the WHWMP include:

- 31 • **NOAA Coral Program.** In February 2011 the US Coral Reef Task Force designated the West
 32 Maui R2R Initiative as the priority partnership in the Pacific. The NOAA Coral Program is
 33 providing funding for project implementation as part of this partnership for Fiscal Years
 34 2013 (October 2012 – September 2013), 2014 (October 2013-September 2014), and 2015
 35 (October 2014-September 2015). DLNR-DAR will administer this funding under Hawai'i's
 36 Coral Reef Conservation Grant. The NOAA Coral Program may also support implementation
 37 projects with internal resources. The NOAA Coral Program provides funding for the West
 38 Maui Watershed Coordinator, which is administered through the National Fish and Wildlife
 39 Foundation.

- 1 • **West Maui R2R Initiative.** USACE funding will be used to help address some of the priority
2 data gaps identified within the WHWMP.⁹
- 3 • **CWA Section 319 Funding** (administered by DOH and sourced from EPA). Since the
4 watersheds will have a WMP that follows EPA guidance (Box 1), and waters are included in
5 the State's Water Quality Monitoring and Assessment Report (Integrated Report in
6 accordance with the CWA Sections 303(d), 305(b), and 314), studies or projects aimed at
7 addressing sources and reducing NPS pollutants may be eligible for this Federal funding.
8 Grant cycles are generally yearly.
- 9 • **NRCS Conservation Practices.** NRCS works with land owners and land managers to fund
10 implementation of practices that conform to practice standards.¹⁰ Funding reimbursement
11 is generally between 75 percent and 90 percent dependent on the parameters established.
12 A conservation plan is typically developed for a given land parcel under management and
13 applicable practices are established.

14 Other potential funding resources include:

- 15 • **Private Funding.** Private land owners could fund management practices on their lands (e.g.
16 agricultural entities, resorts). In most cases the recommended management practices will
17 benefit the local environment as well as contribute to the health of the larger ecosystem.
- 18 • **County of Maui.** Maui County is the owner/operator of properties or structures
19 recommended to be addressed. The County could increase fees (e.g. recycled water rates
20 and sewer user fees) or taxes (e.g. property).
- 21 • **Resort Tax/Fee.** A local resort tax or fee could be levied on 'luxury items and services' or
22 'occupancy' in the Ka'anapali Region to fund infrastructure, services and programs related
23 to improving water quality and coral reef health. These environmental initiatives would be
24 beneficial to the tourism industry.¹¹
- 25 • **Revenue Bond.** Bonds on which the debt service is payable mainly from revenue generated
26 through the operation of the project being financed, or from other non-property tax sources.
27 They may be issued by state and local governments, or by an authority, commission, special
28 district, or other unit created by a legislative body for the purpose of issuing bonds for
29 facility construction.¹² Revenue bonds are usually tax-exempt. State Revolving Fund (SRF)
30 bonds are revenue bonds.
 - 31 ○ **Clean Water State Revolving Fund (CWSRF).**¹³ The CWSRF provides low interest
32 loans to county and state agencies for the construction of municipal wastewater
33 facilities and implementation of NPS pollution control and estuary protection projects.
34 CWSRF funds could potentially be used for wastewater and stormwater infrastructure

⁹ The current focus of USACE funding will be to complete WMPs for the three additional watersheds in the study area.

¹⁰ Many of the practices recommended in the WHWMP adhere to the NRCS Pacific Islands Area practice standards. Applications for NRCS EQIP funds have a cap based on adjusted gross income that make it challenging for large land owners to qualify.

¹¹ For example, a resort tax program in Montana has funded a task force conducting community water quality monitoring, watershed resource assessment, community education and watershed restoration.
http://www.bigskyresorttax.com/benefits_detail.php?ID=16

¹² Revenue bonds now account for the majority of municipal bonds used to finance water, sewer, and solid waste infrastructure in the US.

¹³ http://water.epa.gov/grants_funding/cwsrf/cwsrf_index.cfm; <http://hawaii.gov/wastewater/cwsrf.html>

1 projects, wastewater reuse (e.g. extension of R-1 system), and NPS projects eligible
2 under CWA §319 (e.g. agricultural runoff, stormwater runoff).

3 EPA has developed resources to enable watershed practitioners in the public and private sectors to
4 find appropriate methods to pay for environmental protection efforts. Details are available at
5 www.epa.gov/owow/funding.html and in the *Guidebook of Financial Tools: Paying for Sustainable*
6 *Systems*.¹⁴

7 **2.2.2 Implementation Costs**

8 In general, costs to implement constructed management practices include the following:

- 9 – Engineering design, including all plans, drawings, biddable plans and permit acquisition
- 10 – Product purchase, including shipping cost
- 11 – Construction installation
- 12 – Construction management
- 13 – Annual maintenance

14 Financial resources required to implement the management practices can vary considerably. For
15 example, the cost of a complex technology such as a baffle box is higher than for a simple one such
16 as a vegetated swale. Often the cost for implementing a single unit of a given technology appears
17 relatively high compared with the net benefit provided. However economies of scale can be
18 achieved through multiple installations as the cost to implement per unit management practice
19 often decreases as the number of units installed increases. As the number of units installed goes up,
20 the net benefit in terms of NPS pollutants reduced increases not linearly, but as a power function.

21 Various costs, including capital (equipment), Operations and Maintenance (O&M), and time and
22 training requirements associated with installation and maintenance, will influence selection of
23 management practices. Comparison of cost to NPS pollutant reduction potential also affects
24 selection of practices. Another consideration is initial cost versus long-term maintenance cost.

25 For practices that are not constructed (e.g. fertilizer, irrigation water management plans) costs to
26 implement may include the following:

- 27 – Site-specific testing and creation management plan by qualified firm
- 28 – Cost of materials specified in plan
- 29 – Site management
- 30 – Annual maintenance

31 **2.3 Technical Implementation of Management Practices**

32 Implementation of a given management practice requires gathering supporting design data and
33 assessing technical resources currently available for implementation. The resources required in a
34 given scenario can be determined by factors including complexity of design, site conditions, and
35 regulatory and land owner requirements. Some practices, such as a structurally-based practice (e.g.
36 baffle box) will require development of engineering plans, specifications, and cost estimates,

¹⁴ <http://nepis.epa.gov/Exe/ZyPURL.cgi?Dockey=P100179D.txt>

1 resulting in a relatively high cost to site. Other practices, such as management plans (e.g. fertilizer)
2 are less resource intensive to prepare.

3 **2.3.1 Data and Analysis Recommendations For Design of Management Practices**

4 Design data relevant to the specific site under consideration is important to ensuring proper
5 construction of the practice; determining realistic operations and maintenance requirements; and
6 establishing monitoring protocols to ensure the practice operates as intended for the duration of its
7 life span. Examples of recommended design data and analysis that could influence the successful
8 implementation of a given practice include size of contributing upstream drainage area, soil
9 infiltration rates, and required treatment efficiency of the practice. Appendices B and C contain
10 recommendations for design data and analysis considerations for selected management practices.
11 The recommendations should not be taken as a comprehensive list of detailed design parameters,
12 but rather used as a guide to provide general information on the scope of typical data needs for a
13 detailed design to be developed. Additional data may be required for design of management
14 practices, and not all recommendations may be applicable to a given, individual site. Each site has
15 specific characteristics and constraints that must be taken into consideration before a detailed
16 design is developed for a specific management practice location.

17 **2.3.2 Technical Resources**

18 Technical resources necessary to implement management practices are a function of the complexity
19 of the engineering design, land ownership issues, permit requirements, preparation of biddable
20 construction plans and drawings, and development of a post-installation Operation, Maintenance,
21 and Monitoring Plan. Engineering design includes, but is not limited to, assessing the physical
22 condition of the installation site¹⁵, evaluating design hydrology parameters following County of
23 Maui requirements, sizing and designing management practices, preparing construction plans and
24 cost estimates, preparing detailed installation drawings, acquiring permits, and construction
25 management. These are collectively referred to as 'Plans, Specifications, and Estimates'. In addition
26 to the engineering elements, there are logistical issues associated with taking a management
27 practice from the concept design phase to the implementation phase. Addressing logistical issues
28 requires involvement of persons familiar with the technical elements of the design, the regulatory
29 issues, and construction aspects of installation.

30 Contractors with expertise and knowledge of installing practices are a vital technical resource for
31 the implementation. Since some of the recommended management practices have not been
32 installed or have limited installations in Hawai'i, it will be important that the design and
33 construction manager articulate the objectives and installation nuances to contracting crews, and
34 provide detailed guidance to facilitate correct and expeditious installations.

35 **2.4 Adaptive Management**

36 Adaptive management is defined as a systematic process for continually improving management
37 policies and practices by learning from the outcomes of past and current management activities. An
38 adaptive management process will be used to implement the WHWMP. For example it might be
39 used to adjust priorities and actions should improvements in coral reef health not be achieved.

¹⁵ Assessing a site's physical condition could include geotechnical analysis, locating utilities, inspecting structures (if the practice is a retrofit), and hydrologic analysis.

1 Adaptive management recognizes that there is a level of uncertainty about the 'best' policy or
2 practice for a particular management issue, and requires that each management decision be
3 revisited in the future to determine if it is providing the desired outcome. The approach builds upon
4 prior results, both positive and negative, and allows managers to continually reassess and
5 incorporate new knowledge into management practices.

6 Management actions in a WMP guided by adaptive management can be viewed as hypotheses and
7 their implementation as tests of those hypotheses. *A priori* planning and test design can allow
8 managers to better determine if actions are effective at achieving a management objective. For
9 example, monitoring before and after installation might assess the effectiveness of a management
10 practice. Once an action has been completed, the next, equally important step in an adaptive
11 management protocol is the assessment of the action's effectiveness (results). A review and
12 evaluation of the results allows managers to decide whether to continue the action or to change
13 course. This investigational approach to management means that regular feedback loops guide
14 managers' decisions and ensure that future strategies better define and approach the objectives of
15 the WMP.

16 Adaptive management is a powerful way to approach a methodology for effectively achieving
17 desired results, but it is also time and personnel intensive. Designing a plan that incorporates
18 adaptive management takes more time initially, but can lead to shorter implementation times and
19 greater efficiency later. An adaptive management plan requires an extensive review of current
20 scientific literature and existing management practices, and consultations with experts in the field.
21 It also requires that the implementation of management practices and evaluation protocols be
22 thoughtfully designed, and it must include feedback mechanisms for reassessing management
23 strategies and changing them, if necessary. As additional information about agents and processes
24 impacting the project area becomes available, priority pollutants of concern could shift, with
25 corresponding adjustments to management practices required.

26 Feedback received from members of the West Maui community indicated a desire for the WHWMP
27 to adopt a planning framework that incorporated elements of Hawaiian culture such as traditional
28 Hawaiian land divisions and place names, pre-Western contact land use management practices, and
29 traditional ecological knowledge. The WHWMP would benefit from incorporation of this
30 information in future updates or addendums. Planning processes that use the WHWMP as a
31 template should consider including this information from the beginning.

32

3. Pollution Control Strategies

A set of priority projects and management practices has been identified for Wahikuli and Honokōwai Watersheds¹⁶ along with their calculated and/or relative contributions to pollutant load reduction.¹⁷ Targeted sites range in size from discrete locations (e.g. dam) to large areas (e.g. fallow agricultural fields). A project is comprised of actions to develop details necessary for determining specific locations for installation of practices; preparation of practice specifications; and practice implementation. To the extent possible, projects address a specific land activity or use, feature(s), and conditions and include practices that should be implemented to address the issues. Detailed project design was beyond the scope of the WHWMP.

Since land use and land cover varies greatly between the districts, as do pollutant types and concentrations, a combination of recommended practices will best achieve reduction in pollutant generation and transport. Within the Agricultural Unit, since the two main sources of sediment generation (fallow fields and access roads) cover a large areal extent and are spread out throughout the watersheds, it will be most effective to control the pollutants as close as possible to their source. Impervious surfaces are located throughout the Urban Unit in the form of roads, parking lots, and roofs all which are in proximity to vegetated and landscaped areas.¹⁸ Additionally most of the Urban Unit has storm drainage systems that carry runoff from the impervious surfaces. Practices in the Urban Unit will be installed on the greenscape areas and retrofitted onto the storm sewer system. In general the more management practices that are installed, the more NPS pollution is reduced. The installation of a variety of practices is expected to result in complimentary treatment and greater reduction rates of the total pollution load moving through the system (Box 5).

Box 5. Treatment Chains

Treatment chains are critical to the success of alleviating the heavy pollutant loads generated within the Agricultural and Urban Management Units. A treatment chain is a combination of practices installed and/or constructed within a given pollutant stream. These practices integrate the prevention, capture, and filtering of runoff as it makes its way downslope through the watersheds. The combination of practices increases the cumulative reduction of the target pollutant generated and transported. Treatment chains allow several management practices to function as a collective whole, utilizing the positive aspects that each provides to benefit watershed health. This eases the burden of relying on one specific management practice to function optimally under all storm event and pollutant loading conditions. If one of the treatment practices fails within the chain, it may impact the other management practices, but they will most likely continue to function to some degree of efficiency. In contrast, a single management practice failing may result in failure of the system to be treated at all. For example, the high sediment loadings from the fallow seed corn fields within the Agricultural Unit would be greatly reduced by incorporating a treatment chain including both preventive (conservation cover, vegetated filter strips) and treatment (sediment basins) controls. Treatment chains provide redundancy and a safeguard in the event one practice fails.

Strategies described in this section are aimed at meeting Goals 1-3 (Box 2), which are specifically targeted at pollutant reduction through the implementation of management practices.

¹⁶ As part of the planning process the relevant management measures provided a basis for identifying goals and specific management practices. A set of management practices have been identified for implementation within the Agricultural and Urban Management Units based on the targeted pollutants and hotspots (Table 3). Management practices were chosen based on their expected performance to reduce sediment, nutrient, and other types of NPS pollutants that currently impact the coral reef environment. Appendix B provides background information.

¹⁷ A full discussion of NPS pollutant types, locations of generation, and transportation off the watershed into receiving waters is presented in *Volume 1: Watershed Characterization*. See also Appendix A.7.

¹⁸ Honokowai Watershed: 45 percent imperviousness; Wahikuli Watershed: 17 percent imperviousness (See *Volume 1: Watershed Characterization*, Table 4, which illustrates the percentage of impervious area within the Urban Unit).

- 1 1. Measurably reduce rates of erosion and sediment loads generated on dirt roads, fields, and
- 2 along waterways in the agricultural and urban areas of Wahikuli and Honokōwai
- 3 Watersheds and carried to the coral reefs by 2017.
- 4 2. Measurably reduce fertilizer loss and nutrient loads generated from residential and resort
- 5 properties and agricultural fields of Wahikuli and Honokōwai Watersheds and carried to
- 6 coral reefs by 2017.
- 7 3. By maximizing reuse, decrease the amount of treated wastewater effluent from the Lahaina
- 8 Wastewater Reclamation Facility injected into the ground and transported to the ocean by
- 9 2023.

10 Sites that are generating and/or conveying NPS pollutants with chronic high loads were selected as
 11 priority for implementation of management practices. The prioritization of projects and site
 12 selections are based on the findings of Volume 1 of the WHWMP. They are presented in order of
 13 desired implementation, with the highest priority first (Table ES-1). If funds become available to
 14 implement a lesser priority project or management practice, they should be utilized.

15 **Table 3. Summary of Management Practices**

Management Practice	Definition	Preventative	Treatment
Priority			
Baffle Box	Structural device fitted to storm sewer to capture nutrients, solids/sediments, and hydrocarbons carried in runoff		X
Bioretention Cell (Rain garden)	Shallow depressions excavated and filled with native plants and soil mixtures that allow infiltration, bioremediation and filtering of stormwater routed into the cell		X
Burn Area Emergency Response Plan	A plan that identifies actions, protocols and strategies to implement erosion control practices immediately after a wildfire	X	X
Conservation Cover	Vegetation planted on fallow fields or between plantings of active crop fields to protect soil from erosion	X	
Dam Debris Retrofit	Placement of engineered filter or other device in Honokōwai Structure #8 outlet structure horizontal debris port orifice to trap sediment and other pollutants		X
Fertilizer Management Plan	A plan that quantifies amount and timing of fertilizer applications for agricultural fields and landscaped areas	X	
Road Drainage Improvements	A series of features used to divert water off road surfaces, ditches to drain runoff, and sediment retention basins to collect diverted water and settle particulates.	X	
Road Realignment and Rebuilding	Set of practices for access roads to minimize erosion (i.e. realignment, relocation, revegetation)	X	X
Sediment Retention Basin	Constructed basin that traps sediment-laden stormwater runoff and promotes settling prior to discharge		X
Vegetated Filter Strip	A line of vegetation planted perpendicular to overland flow paths used to filter sediment and other NPS pollutants		X
WWRF Alternate Disposal: Increase Production and Reuse of R-1 Water	Increase usage of R-1 wastewater in Agricultural and Urban Management Units through construction of additional transmission lines and storage reservoirs, and additional customers	X	

16

Management Practice	Definition	Preventative	Treatment
Secondary			
Curb Inlet Basket (with Filter)	Mesh grate placed inside curb inlet used to capture coarse solids.		X
Debris Removal	Removal of illicit dumped debris or rubbish by hand or mechanical methods		X
Erosion Control Blanket / Turf Reinforcement Mat	Manufactured product used to temporarily protect and stabilize exposed ground from erosion due to rainfall and runoff	X	
Facility Stormwater Assessment	Assessment of sites to assess storage of materials and supplies, storm water runoff control, and spill response plans	x	
Good Housekeeping Practices	Actions and activities conducted by watershed dwellers that reduce the generation of NPS pollutants and runoff from their properties. Handling and usage practices that prevent or minimize potential for spills or misuse of fluids and other pollutant sources from activities within the watershed	X	
Gutter Downspout Disconnection	Removal of directly piped, roof-generated stormwater runoff into the S4. Promotes infiltration into landscaped and pervious surfaces and avoids introduction onto impervious surfaces	X	
Illicit Dumping Signage	Erected signage prohibiting dumping of debris or rubbish at established problematic dumping locations	X	
Irrigation Water Management Plan	A plan for matching water use to needs of crops and managing chemicals applied through irrigation water	X	
Natural/Native/Drought Resistant Vegetation	Vegetative species planted on ground surface to prevent soil losses due to rainfall runoff or wind borne sources	X	
Pesticide Management Plan	A conservation practice recommended to be prepared for any activities where pesticides are actively applied, stored, and present the potential for introduction into the environment	X	
Pond Sampling Plan	Schedule of sampling for Kā'anapali golf course ponds to inventory nutrient contributions from the courses	X	
Riprap	Rock armor surface treatment used to reinforce and protect soils to prevent scour, erosion, and sediment loss	X	
Shoreline Erosion Control	Bioengineered designs to stabilize terrestrial soils from wave erosion		X
Storm Sewer Disconnection	Removal of directly piped urban S4 within a developed site and instead promoting onsite retention and treatment	X	
Vegetated Swale	Engineered, vegetated conveyance channel constructed at a gentle grade designed such that water quality treatment can occur for a specific contributing drainage area through infiltration of runoff and pollutants into the soil. Native drought and fire tolerant plants preferred		X
Vehicle Washwater Containment	Practices for retaining and treating used washwater from fleet vehicle rental facilities to prevent discharge into environment		X

1

3.1 Access Road and Trail Inventory Assessment and Proposed Practices

Problem Statement

Dirt access roads and single track trails in the Agricultural District of Wahikuli and Honokōwai Watersheds are a source of sediment, runoff water, and other pollutants that are discharged into gulches, streams, and other waterways that ultimately reach the ocean and adversely impact the West Maui coral reef system.

A portion of the roads that originally were designed and laid out to provide access to the former pineapple and sugar cane fields are now used by coffee growers, land managers and for access throughout the watersheds. Road condition varies depending on present land uses, and some are essentially obsolete. The specific alignment and slope of the roads were designed to maximize field sizes while minimizing surface area dedicated to the road network. Dirt road maintenance practices throughout the watersheds include water bars, broad-based dips, and, within the former pineapple region, terraces used to drain the fields towards and onto the adjacent roads and into gulches. Over time, a lack of road maintenance has resulted in erosion of the roads, and breakdown of the drainage system to control runoff. Additional sediment comes from the eroding fields, which in many areas is transported on the roads. Many of the roads carry the sediments and other associated pollutants to the nearshore ocean environment at rates that are estimated to exceed background levels. Trails include those that were historically constructed and used, and those created adhoc and often illegally, for off road dirt bikes. Similar to roads, trails need to be fitted with practices to control runoff and erosion, and some that are either beyond repair or are trespassing should be obliterated.

Objectives

1. Reduce the amount of sediment generated off earthen access road surfaces.
2. Reduce sediment loads carried by the road network to the nearshore ocean waters.

Recommended Actions

Two steps are recommended to address the problem of sediment delivered onto, generated off of, and carried downstream by earthen roads and trails: (1) complete a road and trail inventory assessment to identify sections of roads and trails in need of repairs and site practices necessary to control runoff and erosion; and (2) install practices to reduce erosion rates and trap sediments.

Road and Trail Inventory Assessment and Identification of Locations and Practices for Installation

The road and trail inventory assessment will identify sections of roads that are eroding and in disrepair, and/or receiving and carrying sediment downstream from nearby agricultural fields. General recommendations to accomplish the inventory assessment and identify locations for installation of practices include:

1. Maps that depict location of all dirt roads and trails should be developed in GIS and geo-referenced. A current high resolution air image should be used as the backdrop to identify

1 roads and trails.¹⁹ It should be expected that some roads and trails overgrown with
 2 vegetation will not be visible on air images, and as a result not included on maps. Hard copy
 3 and digital maps can be used during field work.

- 4 2. The inventory assessment should be conducted by persons with expertise in secondary
 5 earthen road and trail design, drainage standards, and technical knowledge and experience
 6 in developing and installing management practices typically used to control stormwater
 7 runoff and erosion. A qualified designer is responsible for making measurements, collecting
 8 all data and information necessary to complete the assessment, preparing detailed
 9 specifications for recommended practices, and identifying locations for their installation.
- 10 3. The designer will drive/walk roads and trails identified on site maps and those encountered
 11 in the field not depicted on maps. At a minimum, inventory assessment protocols will
 12 adhere to *Conservation Practice Standard: Access Road* (NRCS 2010). The start and end
 13 points of all inspected roads and trails will be recorded on either/or both the hard copy
 14 fields maps and with DGPS accurate to 3 ft (1 m).
- 15 4. The designer will identify all locations for installation of selected practices on field maps
 16 and/or using DGPS. The designer will stake out and layout sites in the field for installation
 17 of all practices. The designer will determine the priority of roads to be repaired.
- 18 5. Design plans, specifications, and cost estimates for all practices will be prepared and
 19 provided to those responsible for installation of practices (e.g. landowner).
- 20 6. Post installation, the designer will inspect practices to insure installation complied with
 21 plans and specifications.

22 Prioritization by Subwatershed

23 During preparation of the WHWMP SRGII conducted limited on the ground inspections of roads in
 24 the two project watersheds and used GIS and high resolution air images to delineate the dirt roads
 25 (road map should be considered approximate). Wahikuli and Honokōwai Watersheds were
 26 subdivided into eight subwatersheds that have been prioritized for inventory assessment (Table 4
 27 and Figure 1).²⁰ For each of the eight subwatersheds the total length and mean slopes of the dirt
 28 roads were computed. Since most of the degraded coral reefs are located in the Kahekili Beach area,
 29 subwatersheds that drain into the ocean along this section of beach, or those subwatersheds with
 30 outlets to the north were prioritized for road repairs (i.e. Honokōwai Subwatershed and
 31 Pohakuka'anapali Subwatershed).²¹ In addition, Wahikuli Subwatershed, which outfalls to the south
 32 of Kahekili, was considered high priority because there are no sediment detention basins on the
 33 gulches that drain it.

¹⁹ During preparation of the WHWMP, SRGII created several GIS shapefiles of dirt roads depicted on high resolution air images that will be available for use in the assessment.

²⁰ The names of the subwatersheds were derived based on local place names and were assigned only to facilitate the prioritization.

²¹ Under normal trade wind weather patterns the nearshore currents flow north to south between the northern boundary of Honokōwai Watershed to Pu'u Keka'a. Sediments and other pollutants carried in runoff and discharged off the subwatershed areas to the north most probably are carried towards the Kahekili section of the coast. Between Pu'u Keka'a and Wahikuli the nearshore currents are variable with eddys that cause reversal of currents under rising and falling tides.

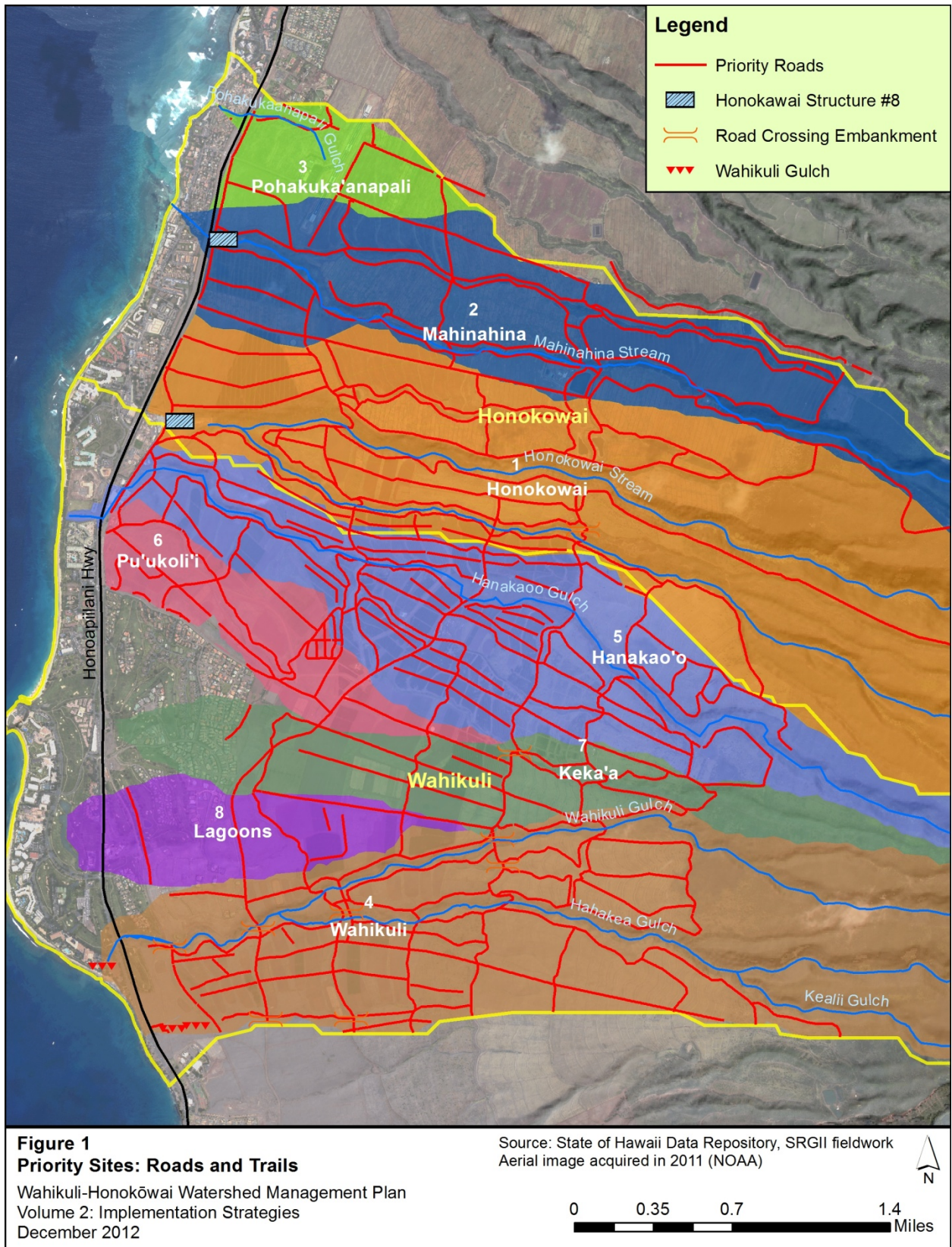

1
2

Figure 1. Priority Sites: Roads and Trails

Table 4. Priority Sub-Watersheds for Road Drainage Improvements

Priority	Subwatershed
1	Honokōwai
2	Mahinahina
3	Pohakuka'anapali
4	Wahikuli
5	Hanakaō'ō
6	Pu'ukoli'i
7	Keka'a
8	Lagoons

Road and Trail Special Considerations

The roads in need of remedial repairs that should be considered priority are generally aligned perpendicular to the ground slope with grades greater than 5 percent and/or those that have frequent terraces or diversions that convey runoff onto the roads and are located along the top of gulches. Some roads and trails observed by SRGII during preparation of the WHWMP appear to be no longer used, and are in such poor condition and/or are so poorly aligned that obliteration may be recommended. In general, obliteration is accomplished by ripping or disking the road deck down to the base of hardpan, covering it with vegetative litter, and revegetating it. The road designer is responsible for acquiring land owner permission prior to recommending obliterating a road. Obliteration and repairs to trails may be more difficult due to access issues for vehicles and equipment. In such cases practices can be installed with hand tools and closures of trails with boulders, ballards, or other structures if equipment needs access. Due to maneuverability of dirt bikes and the skill of riders, efforts to block off trails are often unsuccessful. In some areas it may be necessary to block trails with vegetation such as large trees to prevent them from bypass. The WMMWP is addressing issues on trails in the Conservation District. Management practices they use to control or restrict dirt bike damage include: erosion control and blocking trails with rocks and woody debris.

Practices to Control Erosion and Runoff

Several different practices can be used to control erosion and runoff from dirt roads and trails. Recommended practices are identified below along with brief descriptions. Practice locations and their design specifications will be identified by the person(s) conducting the assessment. The designer shall identify the equipment, materials, supplies necessary to install selected practices and be onsite to direct installation. In most cases it is expected that no single practice will be sufficient to control the rate of erosion, sequester or trap sediment onsite, and contain runoff volumes during extreme runoff events. Most sites will be treated with a combination of practices, creating a treatment chain (e.g. broad based dips outlet to detention basins fitted with energy dissipaters).

Road Surface Improvements

Road surfaces with rills, gullies and other issues that affect road use and/or sources of sediment and concentrated runoff should be repaired. Existing rills, gullies, and channels that have formed on the roads should not be simply filled in, but rather the road regraded so that repeated erosion does not form in the same location. Graded roads should be crowned or cross sloped to facilitate runoff. Roads may require installation of ditches to carry runoff to improved outlets (e.g. energy

1 dissipators or retention basins). Existing water bars and broad-based dips and their outlets should
 2 be inspected. See Appendix B.3 and B.4 for more information on road grading and repair, as well as
 3 *Conservation Practice Standard: Access Road* (NRCS 2010).

4 Road Drainage Improvements

5 A qualified contractor should install and repair broad-based dips, water bars, energy dissipaters,
 6 road grading, and drainage ditches according to NRCS guidelines. The spacing and dimensions of
 7 these features are a function of the road slope and the area of adjacent land that drains onto the
 8 road. In general, close spacing of the features reduces the erosive energy and the sediment
 9 production. Actual site conditions will dictate spacing and feature locations. Where necessary,
 10 ditches should be installed along the road shoulder to carry runoff to either a dip or bar, or directly
 11 into a detention basin. Outlets of bars, dips, and ditches should be fitted with either a detention
 12 basin or energy dissipater. See Appendix B.3 and B.4 for more information on installation and
 13 repair of dirt roads, as well as *Conservation Practice Standard: Access Road* (NRCS 2010).

14 Sediment Retention Basins

15 Specific locations and sizing of sediment basins will be based on site conditions. Basins should
 16 include energy dissipaters, in the form of riprap overflow weirs, at their outlets. Vegetation such as
 17 grasses should be allowed to grow in to provide for filtration and to prevent embankment scouring
 18 and increase filtration. Sediment basins are recommended for placement at the outlets of water
 19 bars, broad based dips and ditches that drain both road and adjacent field runoff. See Appendix B.5
 20 for more information on sediment retention basins, as well as *Conservation Practice Standard:
 21 Sediment Basin* (NRCS PIA 2011a).

22 **Implementation**

23 ***Estimated Cost***²²

24 There are two components of this project: (1) inventory/assessment, and (2) installation of
 25 practices. The inventory/assessment costs include labor for services of a professional engineer and
 26 an assistant to conduct the field work, identify (stake out) locations in the field, and prepare
 27 designs, specifications and estimates for management practices. The installation costs cover
 28 construction work to install practices, including equipment operator, assistant, equipment (e.g.
 29 road grader, loader/excavator) and supplies.

30 While the cost for conducting the inventory assessment portion is relatively uniform across road
 31 conditions, estimating costs for installation is challenging due to the unknown findings of the
 32 assessment. There will be variability in the number and types of practices that will be developed
 33 and installed on the roads. Roads and trails in moderate to good existing condition, and those in
 34 areas with low potential for collecting runoff and eroding, will not require as much design and
 35 installation effort when compared to roads in poor condition and with existing and high potential

²² The cost estimates were prepared using standard guidance documents, cost reference documents, and local pricing information compiled from other construction projects in Hawai'i. Reference documents include the 2012-13 edition of R.S. Means Cost Data book, NRCS cost data, and information supplied by equipment and material suppliers. Estimates are approximate and should be considered provisional. A contingency of 5 percent and Hawai'i General Excise tax of 4.166 percent were also applied.

1 for erosion and runoff accumulation. Estimates in Table 5 were derived by calculating the length of
 2 dirt roads in each subwatershed, obtaining an average slope of these roads, making assumptions
 3 about the percentage of roads needing work, and using standard spacing for management practices
 4 based on road slope and condition. Detailed information is provided in Appendix B.3.

5 **Table 5. Estimated Cost for Road Drainage Improvements**

Subwatershed	Inventory/ Assessment	Installation	Total
Honokōwai Subwatershed	\$10,500	\$56,331	\$66,831
Mahinahina Subwatershed	\$8,750	\$51,314	\$60,064
Pohakukaanapali Subwatershed	\$1,750	\$9,825	\$11,575
Wahikuli Subwatershed	\$10,500	\$61,148	\$71,648
Hanakaō'ō Subwatershed	\$8,750	\$44,811	\$53,561
Pu'ukoli'i Subwatershed	\$3,500	\$15,132	\$18,632
Kekaa Subwatershed	\$3,500	\$20,956	\$24,456
Lagoons Subwatershed	\$1,750	\$8,637	\$10,387
TOTAL	\$49,000	\$268,154	\$317,154

6 **Timeframe**

7 The inventory assessment and installation of practices should proceed immediately, as funding
 8 becomes available, and to the extent possible, be completed by the end of 2017. A phased approach
 9 will be used since it is not likely there will be sufficient funding to complete the work under one
 10 contract. To the extent possible, the roads should be addressed according to the priority order
 11 shown for the eight subwatersheds. If access to lands or other issues preclude adherence to this
 12 priority, the work should proceed as feasible. The Inventory Assessment Phase should be
 13 conducted from 2012-2014, and the Implementation Phase should be conducted from 2013-2017.

14 Funding has been obtained to implement these tasks within some areas of the Wahikuli and
 15 Honokōwai Watersheds, and the West Maui Watershed Coordinator is working with land owners to
 16 gain authorization to conduct the tasks on their properties.

17 **Responsible Entity**

18 The inventory assessment and installation of practices should be conducted by the land owner with
 19 technical assistance from the NRCS/SWCD. Major land owners whose property falls in this project
 20 area include: Maui Land & Pineapple, Inc. (ML&P), Kā'anapali Land Management Corporation
 21 (KLMC), General Finance Group (GFG), and State of Hawai'i. Although financial assistance from the
 22 government for this type of work is potentially available, the financial status of private land owners
 23 is used to determine eligibility for Farm Act related programs (Section 2.2.1).

24 **Area Treated and Load Reduction Estimates**

25 Within Wahikuli and Honokōwai Watersheds there are approximately 102 miles (164 km) of dirt
 26 roads, with an average width of 15 ft (3 m) resulting in 185 ac (75 ha) of road surface area. The
 27 road conditions vary, as does the rate of erosion and sediment loads generated off them along with
 28 additional runoff and sediment routed onto the roads from adjacent lands. Although it is not
 29 possible to make a definitive calculation on the amount of sediment generated, to generate an
 30 estimate on the sediment load reduction for the recommended practices, relative amounts of

1 sediment load reductions are presented. In addition, other pollutants associated with sediments
2 transported in surface waters will also be reduced.

3 Water Bars/Broad Based Dips

4 Used to reduce slope length, thereby reducing erosive energy and down cutting into road and
5 controlling road erosion and sediment generation. Does not control rate of erosion from land
6 adjacent to roads. Proper installation requires outlets be reinforced or fitted with retention basin to
7 prevent erosion. Potential sediment load reduction: 75 to 99 percent.

8 Retention Basin

9 Used to trap sediments, does not affect rate of erosion from landscape. Potential sediment load
10 reduction: 60 to 90 percent. Trapping efficiency is a function of the size of the basin, which is
11 computed based on hydrology and size of drainage area.

12 **Example Road**



13

14

Photo 1. Access Road in Honokōwai Watershed

15 Site Description

16 Photo 1 is a road in Mahinahina Subwatershed within the larger Honokōwai Watershed. It serves as
17 an example of sediment loads generated by erosion off a road in poor condition. The estimated cost
18 and sediment load reduction was derived by preparing a conceptual level build out of practices to
19 repair the road. The rills and gullies on the road surface and its shoulders are approximately 3,100
20 feet (945 m) in length by 3 ft (1 m) in top width by 1 ft (0.3 m) in depth for a total of approximately
21 9,288 ft³ (344 yd³) of sediment that has eroded from this section of road. It appears the sediment
22 generated and delivered off this road is carried to Mahinahina Gulch just upstream of the PL566

1 sediment detention basin, though how much of the sediment has been delivered to the ocean is
 2 unknown.

3 Road specifications derived off GIS were used to compute number of broad based dips and
 4 retention basins fitted with energy dissipators are as follows:

- 5 Average slope = 7 percent
- 6 Road Length = 6,300 ft (1920 m)
- 7 Average Width = 14 ft (4.3 m)
- 8 Number of Broad Based Dips = 29
- 9 Number of Sediment Detention Basins = 11
- 10 Other work: Grade road = 3,100 ft (945 m)

11 Estimated Sediment Load Reduction = 90 percent of existing or 310 ft³ (11.5 yd³)

12 **Table 6. Cost for Improvement of Example Road**

ITEM DESCRIPTION Mahinahina Subwatershed	QUANTITY		MATERIAL & LABOR	TOTAL COST
	TOTAL QTY	U/M	UNIT COST	
Broad Based Dips	4,060	SF	\$0.24	\$974
Retention Basin	3,454	SF	\$0.31	\$1,071
Grade Road	3,500	Ft	\$0.42	\$1,470
Energy Dissipators	200	SF	\$0.24	\$48
Mobilization/Demobilization	1	LS	\$4,500	\$4,500
Subtotal				\$8,063
Contingency 5%				\$403
HI GET (4.166%)	4.166%			\$353
Phase Two: Installation				\$8,819

13

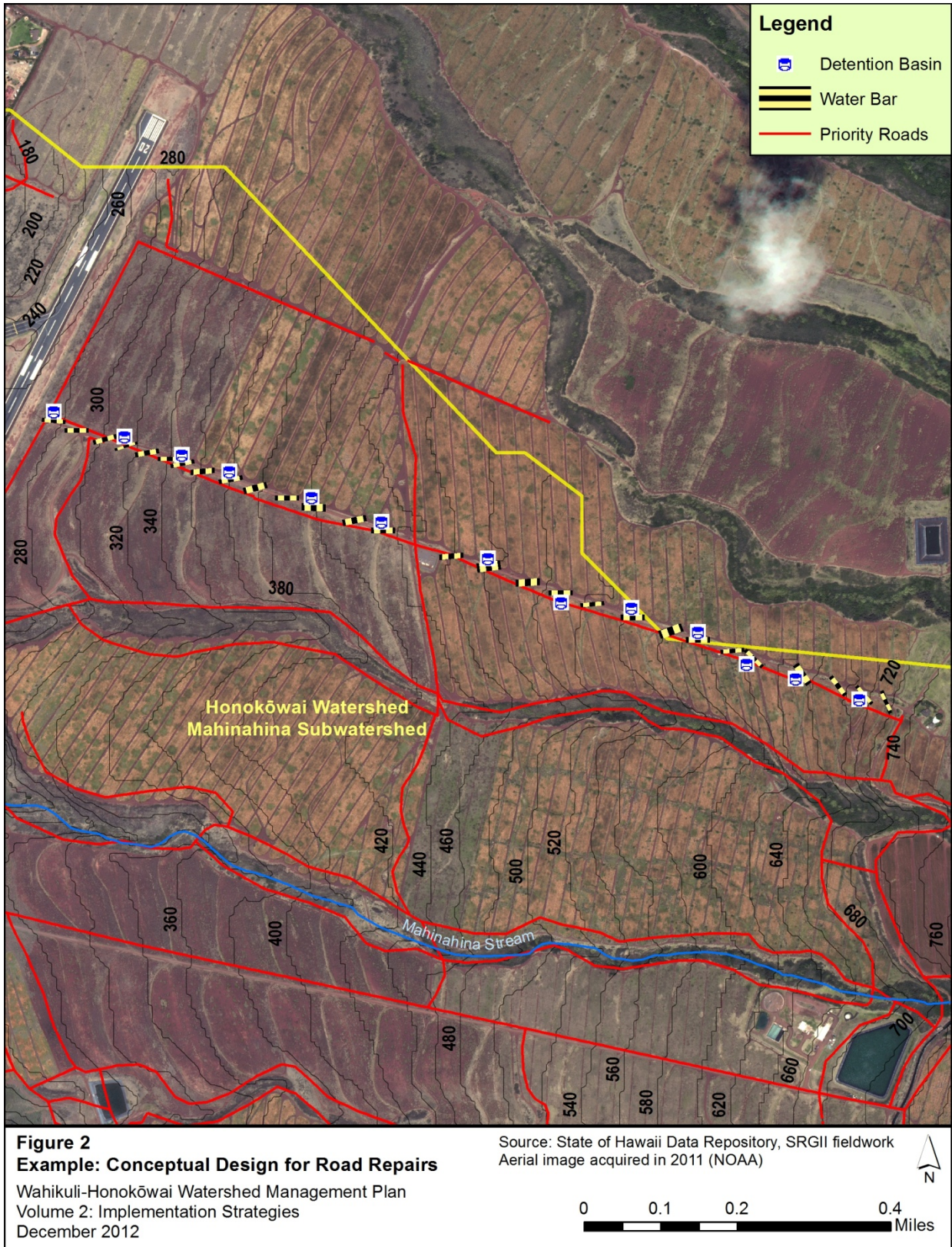

1
2
3
4

Figure 2. Example: Conceptual Design for Road Repairs
 Dirt roads are depicted as red and black lines. Example road extends 6,100 ft from 280 to 740 ft elevation.
 Road starts due east of the Kapahula Airport runway.

3.2 Agricultural Field Inventory Assessment and Proposed Practices

Problem Statement

The majority of the agricultural fields within the Agricultural District of Wahikuli and Honokōwai Watersheds lay fallow and have varying types, density, and vigor of vegetative cover (Table 7). Depending on the ground cover or lack thereof, and rates of erosion and sediment transport, legacy pollutants used during cultivation are carried with overland flow and discharged into gulches, streams, and other waterways that ultimately reach the ocean and adversely impact the West Maui coral reef system.

Fallow agricultural fields have varying amounts of ground cover depending on their elevation and the length of time they have been fallow. The fallow seed corn fields have not been out of cultivation for a long period, and may have less ground cover when compared to the fallow pineapple and sugar cane fields. Since conditions of the fields change with time, an inventory of individual field conditions and degree of vegetative cover will be necessary to accurately determine which are at highest risk for erosion and priority for incorporating conservation cover.

Fallow pineapple fields have a network of terraces that were designed to concentrate and direct surface water runoff off the fields to prevent plant root rot. Many of these terraces are currently filled with sediment, and have outlets that route the sediments and other pollutants attached to them onto the roads and into gulches that drain towards the ocean. There are areas within the Agricultural District that lack of management practices to detain stormwater runoff, control erosion, and reduce export of sediment into the nearshore ocean environment.

Table 7. Acres of Fallow Fields by Crop Types and Subwatershed

Subwatershed	Pineapple	Seed Corn	Sugar Cane	Total
Hanakao'o	0	158	388	546
Honokōwai	570	0	371	940
Kekaa	0	195	155	349
Lagoons	0	147	0	147
Mahinahina	781	0	0	781
Pohakuka'anapali	204	0	0	204
Pu'ukoli'i	0	289	0	289
Wahikuli	0	477	588	1,065
Total	1,554	1,266	1,501	4,322

Objective

Reduce the amount of sediment and associated pollutants generated off agricultural fields and transported to the ocean.

Recommended Actions

Two steps are recommended to address the problem of sediment from agricultural fields: (1) complete an agricultural field inventory assessment and identify sites and practices necessary to

1 control erosion and runoff generated off field surfaces; and (2) install practices to reduce erosion
2 rates and trap sediments.

3 ***Field Inventory Assessment and Selection and Identification for Installing Practices***

4 The field inventory assessment will identify specific fields that are prone to erosion due to a lack of
5 vegetative cover. To the extent possible, specific erosion hotspots (e.g. gullies) located within the
6 fields should be identified and practices to prevent or remediate them developed. General
7 recommendations to accomplish the inventory assessment and identify locations for installation of
8 practices include:

- 9 1. Maps that depict location of fields should be developed in GIS and geo-referenced. A current
10 high resolution air image should be used as the backdrop to visually identify fields.²³
- 11 2. The inventory assessment should be conducted by persons with expertise in agricultural
12 practices and erosion control management practices typically used to control stormwater
13 runoff and erosion. A qualified designer is responsible for making measurements, collecting
14 all data and information necessary to complete the assessment, and preparing detailed
15 specifications for recommended practices.
- 16 3. The designer will inspect fields identified on site maps. The coordinates of the field will be
17 recorded on either/or both the hard copy fields maps and with DGPS accurate to 3 ft (1m).
- 18 4. The designer will identify all locations for installation of selected practices on field maps
19 and/or using DGPS. The designer will stake out and layout sites in the field for installation
20 of all practices.
- 21 5. Design plans, specifications, and cost estimates for all practices will be prepared and
22 provided to those responsible for installation of practices (e.g. landowner).
- 23 6. Post installation, the designer will inspect practices to insure installation complied with
24 plans and specifications.

25 Prioritization by Subwatershed

26 During preparation of the WHWMP SRGII conducted limited on the ground inspections of fields in
27 the two project watersheds and used GIS and high resolution air images collected at several
28 different dates to qualitatively assess agriculture fields. Our observation is that fallow seed corn
29 fields appear to be the most barren, followed by fallow pineapple and sugar cane fields at elevations
30 below 700 ft (213 m) mean sea level (msl). To facilitate prioritization of fields for the inventory
31 assessment Wahikuli and Honokōwai Watersheds were subdivided into eight subwatersheds
32 (Table 8 and Figure 3). Since most of the degraded coral reefs are located in the Kahekili Beach
33 area, subwatersheds that drain into the ocean along this section of beach, or those subwatersheds
34 with outlets to the north were prioritized for field repairs (i.e. Honokōwai Subwatershed and
35 Pohakuka'anapali Subwatershed). In addition, Wahikuli Subwatershed (Wahikuli and Hahakea
36 Gulches), which outfalls to the south of Kahekili, was considered high priority because there are no
37 sediment detention basins on the gulches that drain into it. Sediment from the numerous fallow
38 seed corn fields, as well as the network of eroded and degraded dirt access roads within this
39 subwatershed, drains generally unrestricted into Wahikuli Gulch and discharges to the ocean.

40

²³ During preparation of the WHWMP SRGII created several GIS shapefiles of fields depicted on high resolution air images that will be available for use in the assessment.

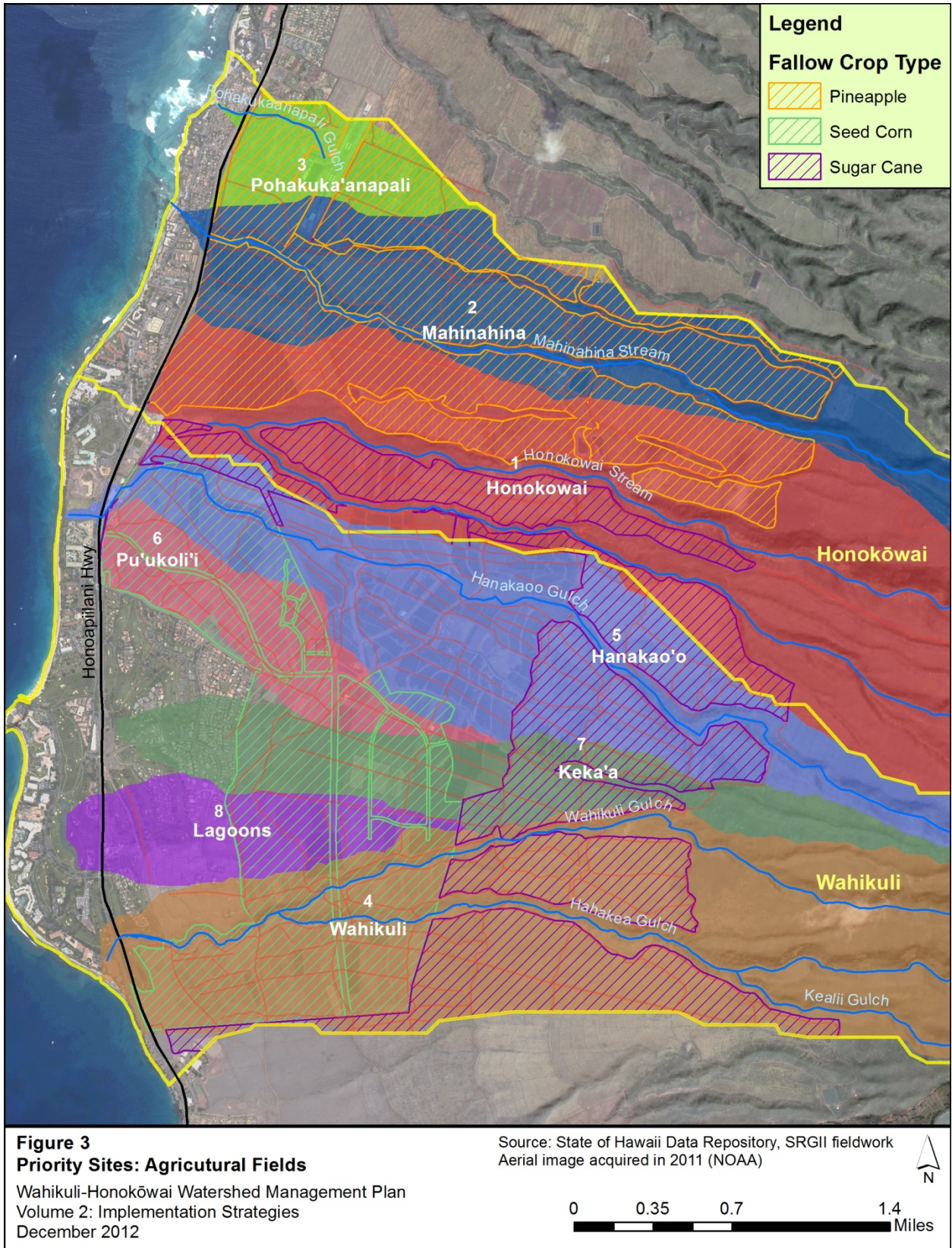

1
2

Figure 3. Priority Sites: Agricultural Fields

1

Table 8. Priority Sub-Watersheds for Field Improvements

Priority	Subwatershed
1	Honokōwai
2	Mahinahina
3	Pohakuka'anapali
4	Wahikuli
5	Hanakaō'ō
6	Pu'ukoli'i
7	Keka'a
8	Lagoons

2 Special Considerations

3 Several alien grass species and other naturally recruiting plants are prone to fire, and may increase
 4 fuel loads and, in the event of fire, its spread, intensity, and frequency. Additionally, during times of
 5 drought, plants may die back, reducing their effectiveness to control erosion rates. When possible,
 6 drought tolerant plants should be used for conservation cover on fallow fields. Due to the presence
 7 of and potential for wildfires, practices in addition to conservation cover are needed to control
 8 erosion. Erosion rates following a fire may be extreme since ground cover will be consumed and
 9 soils exposed. The growth rate of conservation cover will be a function of several factors, primarily
 10 the amount of water available to the plants. Low elevation fields with low rainfall rates will likely
 11 only be sparsely covered, as is the case for many of the fields in this zone presently. In fields where
 12 irrigation water is available, it should be used to promote growth of conservation cover. In areas
 13 where irrigation piping and/or amount of water are limited, vegetative filter strips should be
 14 planted at strategic locations and irrigation water used for plants to become well established.

15 ***Practices to Control Runoff and Erosion***

16 Recommendations for controlling erosion and sediment transport associated with agricultural
 17 fields include non-structural practices (e.g. conservation cover and vegetative filter strips), and
 18 structural practices (e.g. sediment retention basins). Most fields, especially in the lower elevations,
 19 will benefit from conservation cover. Although it may not be possible to plant and irrigate large
 20 tracts of land (a traditional application of conservation cover), allowing plants to recruit across the
 21 fallow fields regardless of species types will provide some form of cover without expending
 22 resources. In most fields it is expected that no single practice will be sufficient to both control the
 23 rate of erosion and sequester or trap sediment onsite. Most sites will be treated with a combination
 24 of practices, normally referred to as a treatment stream.

25 Conservation Cover

26 Conservation cover can be either plants that grow without assistance that recruit and grow on
 27 fields such as alien grasses or other plants that are cultivated, irrigated, and fertilized. The primary
 28 objective is to protect soil surfaces using plant cover at sufficient density to protect from rainfall
 29 and runoff. Conservation cover may also include vegetated litter and crop residue, erosion mats or
 30 blankets, and other items that protect the ground surface while at the same time allow for rainfall
 31 to infiltrate into soils. Impervious surfaces are not considered conservation cover. Specific fields or
 32 sections of them that need conservation cover will be determined by the person conducting the

1 inventory assessment. Criteria include existing cover density and types of plants, field slopes, and
2 proximity to waterways.

3 Sediment Retention Basins

4 Sediment retention basins can be placed along overland flow routes to intercept flow and entrained
5 sediment. Basins should include energy dissipaters, in the form of riprap overflow weirs, at their
6 downstream end. If possible, basins should be lined with vegetation to avoid embankment scouring
7 and increase filtration. Basins can range in size depending on the area of runoff they are treating. In
8 fallow pineapple fields micro sized basins can be installed along the center of field terraces to retain
9 water and sediments on the field. See Appendix B.5 for more information on installation of
10 sediment retention basins, as well as *Conservation Practice Standard: Sediment Basin* (NRCS PIA
11 2011a).

12 Contour Furrows

13 A contour furrow is a shallow depression excavated along the contour of the ground slope that is
14 used to intercept sheet flow. The interception of the water reduces the runoff concentration and the
15 erosive energy. This simple design can be placed at strategic locations such as below a road or other
16 source areas of runoff.

17 Vegetated Filter Strips

18 Vegetative filter strips should be placed within and/or at the edges of fields to slow surface water
19 runoff and filter sediments. The specific locations will be determined in the field by the person
20 conducting the inventory assessment. They should be coordinated with placement of sediment
21 basins to yield the maximum capture of sediment possible. Filter strips can be comprised of a
22 variety of plants depending on site conditions and access to irrigation water. Filter strips can also
23 function as wind breaks on fields exposed to wind erosion. Proper siting will result in retention of
24 sediment near the various sources, with the added benefit of reducing volume and travel length of
25 runoff flow, thereby decreasing potential for erosion. See Appendix B.6 and *Filter Strip* (NRCS PIA
26 2011c).

27 **Implementation**

28 ***Estimated Cost***

29 The cost to perform the inventory and assessment is difficult to estimate since field conditions vary
30 as will the amount of field time needed. Recent high resolution air images can provide an initial
31 screening and give the inspector an idea of priority fields. In general, fields adjacent to gulches and
32 those in the lower elevations should be inspected first. Table 9 provides a rough order of magnitude
33 cost to inventory the fields in each of the eight subwatersheds. The cost is an estimate based on
34 experience and includes (1) time for a two person crew to conduct the inventory and assessment;
35 (2) field supplies to stake out locations for practices; (3) time to develop drawings and derive cost
36 estimates for installation; and (4) time to inspect installation of practices by construction
37 contractors. A conservative and provisional cost per acre to complete these steps is \$10/acre.

Table 9. Estimated Cost for Agricultural Field Inventory and Assessment

Priority	Subwatershed	Fallow Field (ac)	Cost
1	Honokōwai	940	\$9,400
2	Mahinahina	781	\$7,810
3	Pohakuka'anapali	204	\$2,040
4	Wahikuli	1065	\$10,650
5	Hanakaō'ō	546	\$5,460
6	Pu'ukoli'i	289	\$2,890
7	Keka'a	349	\$3,490
8	Lagoons	147	\$1,470
Total		4321	\$43,210

Timeframe

This task should begin immediately and continue until all fields are assessed. All fields should be assessed by the end of 2014. Installation of practices should be installed within one year of completing the inventory and assessment.

Funding has been obtained to implement these tasks within some areas of the Wahikuli and Honokōwai Watersheds, and the West Maui Watershed Coordinator is working with land owners to gain authorization to conduct the tasks on their properties.

Responsible Entity

The inventory assessment and installation of practices should be conducted by the land owner with technical assistance from the NRCS/SWCD. Major land owners whose property falls in this project area include: ML&P, KLMC, GFG, and State of Hawai'i. Although financial assistance from the government for this type of work is potentially available, the financial status of private land owners is used to determine eligibility for Farm Act related programs (Section 2.2.1).

Area Treated and Load Reduction Estimates

A 6 acre (2.4 ha) fallow seed corn field located in Wahikuli Watershed was assessed to generate an estimate of sediment load reduction. In its current condition the field has an estimated sediment loss of 5.8 tons/acre/year computed using the NRCS Revised Universal Soil Loss Equation (RUSLE2) program. An estimate of the potential reduction of soil loss off the field and sediment trapped on it is presented. If ground cover is increased by 50 percent with a combination of bunch grass and shrubs the soil loss drops by nearly 60 percent to (2.3 tons/acre/year). If a series of vegetative filters comprised of grass strips are installed a 60 percent reduction in sediment lost in overland flow is estimated. The total area that could potentially be treated includes all fields, however, it is reasonably expected that only a subset of the fields will actually be treated. It is not possible to extrapolate load reductions for all fallow agricultural fields in the eight subwatersheds since existing soil losses are unknown and the rate of sediment loss from the fallow seed corn fields is changing due to encroachment and natural recruitment of vegetation onto the fields.

3.3 WWRF Alternate Disposal: Increase Production and Reuse of R-1 Water

Problem Statement

Viable recommendations are needed for increasing wastewater reuse to 100 percent, helping preserve potable water supply, and decreasing the volume of effluent disposed into County of Maui injection wells. *Maui's Wastewater Management Future: Charting a Course to Increased Water Recycling and Reduced Reliance on Injection Wells* summarizes recommendations issued by the Maui Wastewater Community Working Group (CWG) (Maui DEM 2010). The CWG was composed of community stakeholders within Maui including large and small-scale ranchers and farmers, environmentalists, developers, utilities, scientists, and others. The CWG considers 100 percent recycling to be the ultimate goal (Maui DEM 2010).

There are three potential options for reducing and/or discontinuing disposal of treated effluent wastewater into the Lahaina WWRF injection wells that will reduce pollutant loadings to nearshore ocean waters, listed in order of feasibility.

1. Treatment of all wastewater effluent to R-1 standards and increase in the customer base that utilizes the R-1 reclaimed wastewater network. [Discussed in this section].
2. Disposing of effluent into a deep injection well.
3. Construction of a submarine outfall pipeline into the ocean in lieu of the current injection well method for ultimate disposal.

Of these three options, increasing R-1 usage within the watersheds is the only viable option economically and environmentally. Disposing of effluent via deep injection well(s) is full of hydrologic uncertainties and is therefore not considered feasible. A deep ocean outfall is primarily unfeasible due to the high cost of constructing a pipeline. Although the offshore waters are Class A per State HAR §11-54 and could accommodate a new discharge, the waters are highly valued for environmental, cultural, and recreational uses (e.g. Hawaiian Island Humpback Whale National Marine Sanctuary). These uses would need to be addressed when considering any new disposal methods.

Objective

Reduce the volume of treated effluent waste water that is injected into wells at the LWRF. A corresponding reduction in the volume of water sourced to the injection wells and discharged as submarine ground water in seeps near Kahekili Beach is expected, resulting in improved water quality in waters near the seeps.

Recommended Actions

Extending R-1 Recycled Water within the project area to include resort, commercial, and residential properties for use as irrigation will decrease the volume of effluent injected into the ground and making its way to the ocean waters at Kahekili Beach Park. At present the length and number of pipelines are limited, resulting in limited numbers of users of R-1 water for irrigation. Extending the pipeline system to distribute R-1 Recycled Water within the project area involves significant infrastructure costs.

1 R-1 Recycled Water expansion includes increasing the R-1 service customer base through
 2 installation of new pipelines to serve agriculture lands within Wahikuli Watershed; and the future
 3 developments in both Wahikuli and Honokōwai Watersheds.²⁴ Expansion of the R-1 system will
 4 result in less directly injected effluent into the wells at the WWRF; reduced nutrient and other
 5 pollutant loadings introduced via groundwater into coastal waters; and the promotion of water
 6 reuse within the watershed. Extension of R-1 use meets several objectives of the *West Maui*
 7 *Community Plan* including (Maui County Council 1996):

- 8 • Expansion of R-1 use, with encouraging park, golf course, landscape, and agricultural uses of
 9 recycled water;
- 10 • Usage of recycled water for irrigation purposes in order to promote conservation of potable
 11 water;
- 12 • Continue to investigate and implement appropriate measures to control the proliferation
 13 and growth of algae within ocean waters;
- 14 • Reuse recycled water for irrigation and other suitable purposes in an environmentally
 15 sound manner.

16 The County of Maui has a commitment to provide R-1 water for future commercial, industrial, and
 17 agricultural developments. Included in the CWG consensus recommendations is to implement
 18 existing Department of Environmental Management plans to increase recycled water use from 22
 19 percent to 40 percent (Maui DEM 2010).²⁵ In order to meet these goals, and the goal of eventually
 20 increasing wastewater reuse to 100 percent, recommendations for required improvements that
 21 must be made to the R-1 system were made in several categories (Maui DEM 2010):

- 22 • Wastewater collection system (reduce saltwater intrusion)
- 23 • Additional UV capacity = more R-1 production
- 24 • Elevated storage of R-1 water within reservoirs; and associated design & construction
- 25 • In-plant storage capacity
- 26 • Distribution pipe lines for R-1 transmission

27 **Wastewater Collection System**

28 Challenges with salinity in the wastewater system will require remediation. These challenges
 29 include concentrations of Total Dissolved Solids (TDS)²⁶ of 1,400 mg/L; and Chlorides, with a
 30 concentration of 600 mg/L. Potential solutions to the salinity issue include: identification of
 31 seawater intrusion areas, lining the gravity sewer pipes, mitigation, and blending.

32

²⁴ These developments will take place in both the Agricultural and Urban Management Units, vary in size and scope, and are at various stages of approvals (*Volume 1: Watershed Characterization* Section 3.3.3).

²⁵ Implementation will be accelerated to achieve a higher percentage of reuse (beyond 40 percent), based on the ability to generate additional, non-sewer fee revenues and to identify additional users (Maui DEM 2010).

²⁶ “Dissolved solids” refer to any minerals, salts, metals, cations or anions dissolved in water. TDS include inorganic salts (principally calcium, magnesium, potassium, sodium, bicarbonates, chlorides and sulfates) and some small amounts of organic matter that are dissolved in water. The suspended or colloidal particles, commonly referred to as TSS are all the extremely small suspended solids in water that will not settle out by gravity.

1 **Additional UV Capacity**

2 Installation of additional UV disinfection at WWRF will allow additional capacity for treatment of
3 wastewater to R-1 standards. Maui County plans to add additional UV disinfection capability by the
4 end of Calendar Year 2013.

5 **Storage**

6 Storage tanks hold R-1 water produced by the WWRF prior to distribution. There is currently a 6.0
7 million gallon (MG) capacity reservoir (containing a blend of ditch and R-1 water) on ML&P land.
8 Additional capacity is needed to help efficiently distribute existing and potential future R-1 water to
9 users. The County of Maui plans to construct a 1.0 MG R-1 covered storage tank at approximate
10 elevation 200 ft (61 m) on Department of Hawaiian Home Lands (DHHL) land. DHHL will provide
11 County of Maui a parcel of land two acres (0.81 ha) in size via license agreement (Maui County,
12 pers. comm.). The tank design is currently underway and construction is planned for Fiscal Year
13 2014. The existing 20 in (51 cm) line running along a DHHL parcel in Honokōwai Watershed has
14 been used in the past and will provide R-1 water to the future tank. The tank will be sufficient to
15 supply R-1 water to existing customers as well as customers within the near future who are in close
16 proximity to the existing R-1 water pipe lines. The goal of these improvements is to supply 110,000
17 gallons per day within two years for commercial developments, and 25,000 gallons per day to
18 industrial developments within five years (Maui DEM 2010).

19 Additional storage (e.g. WWRF in-plant storage and potentially another one million gallon tank
20 adjacent to the initial one) will be required in the future if the County of Maui decides to construct
21 additional pipe lines to distribute more R-1 water (Maui County, pers. comm.). Construction of
22 elevated storage tanks will result in a fully pressurized distribution system.

23 **Distribution Lines**

24 There is existing infrastructure that can be utilized and expanded upon to increase the service area
25 for R-1 use (Chart 1). There are two pipelines that originate at the WWRF. The first is a 16" line that
26 services the Kā'anapali Golf Course and its 2.0 MG capacity reservoir. This pipeline has a lateral
27 near the WWRF that services the Honua Kai Resort, and a lateral extending from the golf course
28 reservoir that services the Hyatt and the lower links of the golf course and common properties
29 managed by KOA. A second pipeline runs in the *mauka* direction and terminates at 700 ft (213 m)
30 msl. It is fitted to a 6.0 MG ML&P reservoir at 600 ft (183 m) msl, and ends at a second reservoir (7
31 MG capacity) at the 700 ft (213 m) msl elevation. The pipeline is currently used infrequently or not
32 at all, and neither reservoir receives water due to the high pumping cost. The County is constructing
33 a 1 MG reservoir along the pipeline at 200 ft (61 m) msl. Future agricultural development projects
34 on lands in Honokōwai Watershed may be possible if R-1 water is available for irrigation. The
35 Honokōwai DHHL project designated as "Planned/Committed" calls for a 1,250 single family unit
36 future development that could potentially benefit from the incorporation of this R-1 system to meet
37 landscaping irrigation needs upon project build-out.²⁷ Other future development projects within
38 the Agricultural Management Unit may also benefit from the use of R-1 water for landscaping,
39 although transmission lines would need to be constructed.

²⁷ Per DOH regulations, in order to avoid cross connections with potable water, recycled water can only be used at single family homes if a homeowner's association maintains the irrigation systems through a landscaping contractor (County of Maui, pers. comm.).

1 There are no existing R-1 service lines within the Agricultural Management Unit of Wahikuli
 2 Watershed. The fallow seed corn fields and the actively cultivated coffee orchards in Wahikuli
 3 Watershed present a current irrigation need that could potentially be met with the use of R-1 water.
 4 Due to brackish water inflows into the sewer lines upstream of the LWRF, R-1 water may be too
 5 saline for some plant types. An R-1 transmission line constructed to service these fields would most
 6 likely tie in to the existing line that currently runs between the WWRF and the Royal Kā'anapali Golf
 7 Course. Prior to any scenario that delivers water for agriculture use, a cost benefit analysis will
 8 need to be conducted to determine feasibility. The multiple future development projects within
 9 Wahikuli Watershed that have "Planned/Committed," "Planned/Designated," and "Proposed"
 10 designations include a mixture of single family and multi-family units that could also benefit from
 11 an extension of the R-1 system to meet their landscape irrigation needs. Future projects abutting
 12 Honoapi'ilani Highway would most likely be the most cost feasible for R-1 service as they are
 13 located closest to the current R-1 transmission line.

14 ***R-1 Reuse for Irrigation***

15 R-1 reuse for irrigation should be incorporated at various sites within the watersheds based on in-
 16 place nutrient and hydrology management methods. A given site should have management
 17 methods that will prevent leaching of R-1 water through the vadose zone, or excess R-1 water to be
 18 lost from excess application and resulting overland flow. The ultimate goal for R-1 reuse is
 19 application at a rate that matches that of the uptake of plants onsite. R-1 water should be applied
 20 through irrigation in such a way that it results in final treatment and filtering of potential residual
 21 contaminants contained in it through the vadose zone. Liberal R-1 water application should not be
 22 encouraged due to potential for Nitrogen, Phosphorus, and other contaminants to leach through the
 23 soil and into groundwater and to the ocean.

24 **Implementation**

25 ***Estimated Cost and Funding***

26 Funding sources for construction of the R-1 Storage Tank and Related Infrastructure include: SVO
 27 Pacific (North Beach, Lot #3); Hyatt; and Bureau of Reclamation, Title XVI (accounting for 25
 28 percent of total developer contributions; requires matching funds) (Maui DEM 2010). West Maui
 29 Developers (Honua Kai North Beach Lot #4) has contributed funds for WWRF improvements such
 30 as upgrades to the existing UV channels and infrastructure.

31 The County has identified four separate projects related to extending the R-1 wastewater network.
 32 Estimated construction costs as of 2010 are: Pressurized System Expansion: \$8.78 M²⁸; Kā'anapali
 33 Parkway Expansion: \$6.56 M; Lower Honoapi'ilani Road Extension: \$2.18 M; and Upper Kā'anapali
 34 Condominium Extension: \$10.69 M.

35 Private funds may be contributed in the future from several customers (resorts) that will be
 36 utilizing the water for irrigation purposes.²⁹ Additional potential funding sources for future system
 37 expansion include (Maui DEM 2010):

- 38 • WWRF (State Revolving Fund, Bonds)

²⁸ Required before other Lahaina projects.

²⁹ Several of the North Beach lots along Honoapi'ilani Highway will be future customers.

- 1 ○ Recycled water rates and sewer user fee significant increases
- 2 • Grants
- 3 • Developers
- 4 • Major Land Owners and/or Businesses
- 5 • Water Department
- 6 • Property Taxes

7 **Timeframe**

8 Maui County is proposing to implement recommendations contained in the CWG recommendations
 9 by 2025 (Maui DEM 2010). Practically speaking, the improvements would be phased in as funds
 10 become available.

11 **Responsible Entity**

12 County of Maui, Landowners

13 **Area Treated and Load Reduction Estimates**

14 Because of the uncertainty that exists regarding water quality sourced to the WWRF in the
 15 nearshore waters, it is not possible to quantify pollutant load reductions for the various component
 16 upgrades that may increase R-1 water reuse and reduce the volume of effluent injected. It is
 17 reasonable to assume that a decrease in the volume of effluent injected into the wells at the WWRF
 18 will result in a proportional decrease of the total volume of effluent that discharges via submarine
 19 seeps along the Kahekili Beach area. This will also reduce the total loads of various contaminants
 20 carried in the effluent since the total load is the product of the water volume times the
 21 concentration of a contaminant. Upgrades to the WWRF in the form of disinfecting all effluent
 22 waters will result in R-1 quality of water that is either reused or disposed of in the injection wells.
 23 This is expected to reduce virus and bacteria concentrations, resulting in water that does not pose a
 24 human or environmental health risk.

25
 26

Chart 1. Proposed West Maui R-1 Transmission System Improvements

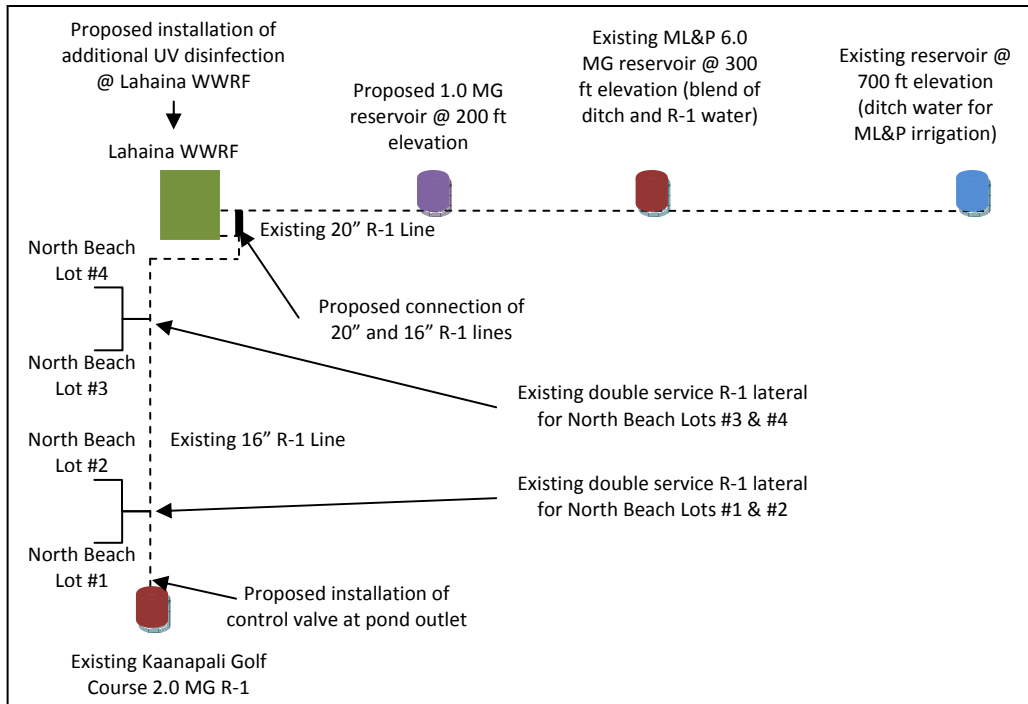



1

2

Figure 4. Wahikuli Urban District: Selected Management Practice Locations

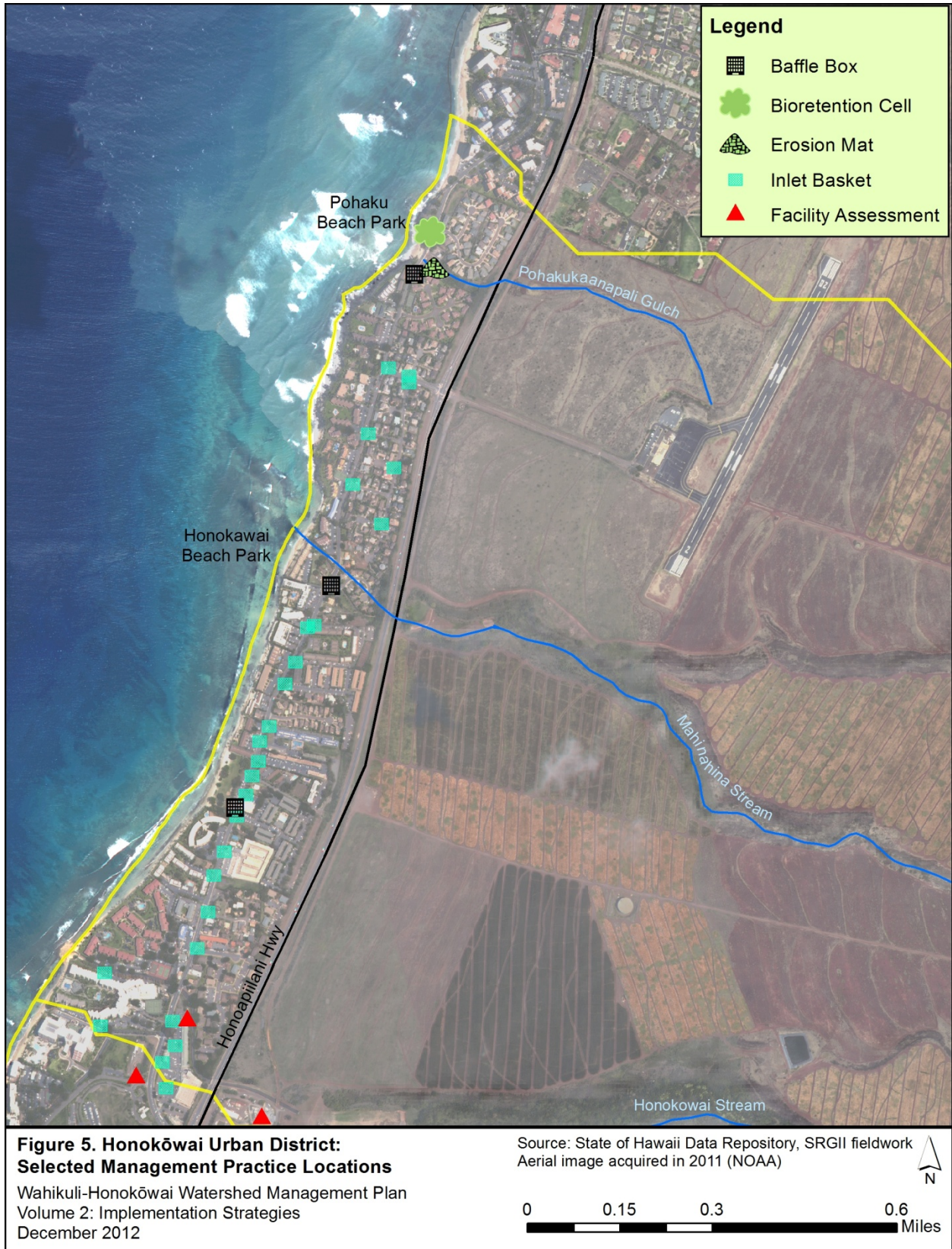

1

2

Figure 5. Honokōwai Urban District: Selected Management Practice Locations

3.4 Honokōwai Structure #8: Dam Analysis and Solution Design Development

Problem Statement

Honokōwai Structure #8 (located on Honokōwai Stream) receives runoff from the Conservation and Agricultural Districts of Honokōwai Watershed. During and following periods of moderate to high rains, Honokōwai Stream flows and carries fine and coarse sediments and other pollutants that are attached to the sediment particles, as well as plant matter, and animal waste. A portion of the pollutants carried in the water, primarily the fine matter, makes it past Honokōwai Structure #8 and flows to the ocean.

The term “desilting basin” is commonly used to describe Honokōwai Structure #8, however it is somewhat of a misnomer. The intended design of the basin and outlet structure was to capture coarse vegetation, debris and rocks, thereby its effective function is as a “debris basin”. It appears to function adequately to retain coarse sediment and plant matter. However, the design of the concrete outlet structure and outlet ports fitted in it allow fine sediment to readily pass through the basin untreated, into the concrete outlet channels, and ultimately into the ocean.³⁰ This fine sediment is of primary concern because of impacts to the coral reef resulting from its presence in the nearshore coastal areas.

Additionally, during flows generated by storm events exceeding the 2-year storm recurrence interval, the emergency overflow spillway for Honokōwai Structure #8 conveys water around the dam to the concrete channel downstream of the dam. The emergency spillway channel has unlined banks and bed that appear to be erodible and is a likely source of sediment when conveying stormwater. The sediment-laden runoff is then readily transported directly to the ocean through the outlet channels.

Objective

1. Increase trapping efficiency of fine sediment in the basin by 50 percent thereby decreasing the sediment load discharging from Honokōwai Structure #8 to the ocean.

Recommended Actions

Engineering Analysis and Development of Retrofit Designs

There are two ways to increase trapping efficiency of fine sediments that enter the Honokōwai Structure #8. The first is to increase retention time of impounded water thereby allowing more settling of fines out of the water column. This approach is challenging since the soils eroded off the watershed are fine silty and clay particles with extended settling times, making gravity settling difficult. The second is to actively filter or trap sediment particles using engineered structures and/or vegetation. Any practice or set of practices will require detailed engineering analysis and design to determine design effectiveness and to insure that the design does not alter the structural integrity of the dam and its features, or adversely impact the reservoir/basin hydrology. Since the

³⁰ The six outlet port orifices are paired and arranged vertically with the lowest pair approximately 2 to 4 feet (0.7 to 1.2 m) higher than the low point of the basin. They have an opening of approximately 4 ft² (0.4 m²). The result is that flows entering the basin are impounded only to the invert of the lowest pair of outlet ports, which then allows any additional and higher water levels to flow through the basin with minimal decrease in velocity and settling of fine suspended sediments.

1 dam is registered and regulated under the Hawai'i Dam and Reservoir Safety Act of 2007, any work
2 on the dam and/or within the basin will need to be coordinated with and approved by both the dam
3 owner (County of Maui Department of Public Works) and DLNR Engineering Division Dam Safety
4 Program. Several conceptual level designs were considered to increase trapping efficiency of fine
5 sediments. All the conceptual level designs will require detailed engineering designs prepared by a
6 professional engineer and analysis that will include but not be limited to: sediment particle size
7 analysis, hydrologic study, hydraulic study, and cost benefit analysis.



8
9 **Photo 2. Honokōwai Structure #8 (Aerial)**

- 10 1. Retrofit the basin's six outlet ports with a sediment filtration device such a hydro screen.
- 11 2. Install a baffle box or other structural treatment practice within the concrete outlet channel
12 to capture and retain pollutants downstream from Honokōwai Structure #8. See Appendix
13 B.1.
- 14 3. Install vegetated filter strips aligned perpendicular to flow direction in the basin to slow
15 flow, and intercept sediments, to settle and filter sediments. See Appendix B.6.
- 16 4. Construct a series of infiltration trenches aligned perpendicular to flow direction within the
17 basin. Objective is to slow flow by increase roughness and inducing sediment settling in
18 trenches.
- 19 5. Increase storage volume of basin below the invert of the outlet ports by excavating within
20 the basin. Purpose is to increase time of retention of impounded water and increase
21 sediment settling.
- 22 6. Increase storage volume of basin above invert of the outlet ports by closing them off and
23 using the concrete outlets on top of concrete outlet structure as the primary outlet works.
24 Purpose is to increase time of retention of impounded water and increase sediment settling.
- 25 7. Stabilize the interior face Honokōwai Structure #8 dam embankment using non-degradable
26 erosion mat, vegetation or shotcrete. Objective is to prevent erosion of dam face and input
27 of sediment into basin. Note this element is low priority. See Appendices C.3 and C.8.



Photo 3. Honokōwai Structure #8

Detailed designs for the recommended actions should include specifications for stabilizing the emergency spillway channel so that future erosion and sedimentation will not be generated from its banks or bed during runoff events. Any design will have a maximum volume of water that can be treated. The selected design and features should be designed to treat the more frequently occurring runoff volumes. All will require post-installation maintenance of varying frequency.

Implementation

Estimated Cost

Table 10 details an order of magnitude cost estimate to prepare an engineering plan that includes plans, specifications, construction cost, and cost to prepare and acquire permits, for one or more of the conceptual level recommendations for Honokōwai Structure #8. It is not possible to generate construction cost estimates until a detailed design is completed.

Table 10. Cost Estimate for Developing Honokōwai Structure #8 Detailed Engineering Design

Title	Rate/hr	Task (hr) Hydrology /Hydraulics	Task (hr) Engineering Design	Task (hr) Permits	Total Hours	Total Cost
PM	\$135	4	16	32	52	\$7020
Engineer III	\$124	40	80	24	144	\$17856
Engineer I	\$110	48	56	32	136	\$14960
Environmental Specialist	\$88	16	24	120	152	\$13376
Survey (topo / property)	\$200	0	160	0	160	\$32,000
TOTAL		108	176	208	644	\$85,212

1 **Timeframe**

2 An engineering design for Honokōwai Structure #8 should be completed by 2015.

3 **Responsible Entity**

4 As the owner and operator of the structures, the County of Maui Department of Public Works is
5 responsible for any improvements to Honokōwai Structure #8.

6 **Area Treated and Load Reduction Estimates**

7 Honokōwai Structure #8 receives runoff from approximately 2,350 acres (951 ha) of land within
8 the larger Honokōwai Watershed. The area represents the treatment area of the dam and detention
9 basin. Runoff entering the basin and passing through the structure contains sediment in suspension
10 in varying concentrations. The targeted load reduction will vary based on the volume of discharge.
11 For low magnitude more frequent runoff events (<=2 year) the target load reduction is 70 percent.
12 For high magnitude discharges, or the infrequent events the load reductions will be lower due to
13 water volumes that will most probably exceed treatment capacity and result in flow through
14 condition in the basin. Regardless of discharge the target load reduction for discharges between the
15 2 and 25 year discharge is 40 percent. Note the percent reductions are relative to the suspended
16 sediment concentrations.

17 **3.5 Wahikuli Gulch: Gulch Analysis and Solution Design Development**

18 **Problem Statement**

19 Wahikuli Gulch receives and transports runoff containing pollutants generated within the
20 Conservation, Agricultural, and Urban Districts. The segment of Wahikuli Gulch between
21 Honoapi‘ilani Highway and the coastline within the Urban District is unstable. During periods when
22 the gulch carries water this segment adds additional sediment eroded from the unstable bed and
23 banks of the channel. Along this segment there are several locations where concentrated overland
24 flow from the Hanaka‘ō‘ō Cemetery and the Hyatt parking lot flow onto unprotected banks eroding
25 the unprotected banks and delivering pollutants. The proximity of this segment to the ocean makes
26 this unstable channel a high priority for remedial action.

27 **Objective**

- 28 1. Stabilize the bed and bank of the channel of Wahikuli Gulch between Honoapi‘ilani Highway
29 and the ocean to prevent erosion and generation of sediment that is discharged into the
30 ocean.

31 **Recommended Actions**

32 **Engineering Analysis and Development of Stabilization Designs: Wahikuli Gulch**

33 The recommended strategy for stabilizing the segment of Wahikuli Gulch between Honoapi‘ilani
34 Highway and the coastline requires the development of a detailed engineer/geomorphologic design
35 that prescribes installation of features to protect the bed and banks of the channel. The conceptual
36 level design involves stabilizing the channel banks with a combination of practices including
37 bioengineering (using plants and synthetic fabrics), earth work on slope banks to stabilize inclines,
38 and use of coir logs to stabilize slopes and protect the toe of the channel (Figure 6). In addition it is

1 recommended that at least three channel grade control structures in the form of upstream pointing
 2 vortex weirs constructed with keyed in boulders be installed in the channel bed to set a grade line
 3 of approximately 1.5 percent. The design should also consider hardening discrete locations that
 4 cannot be stabilized with fabrics, vegetation and manipulation of geometry.³¹ The conceptual design
 5 is predicated on the assumption that R-1 water currently used on the Hyatt property adjacent to the
 6 gulch can be used to irrigate vegetation that will be installed as part of the design. The channel
 7 stabilization will reduce erosion and enhance the area’s viewshed. Recommended management
 8 practices include:

- 9 1. Earthworks: the channel’s geometry will be altered along sections where banks are unstable
 10 due to slope angle and/or unconsolidated materials. Where possible banks will be sloped to
 11 2:1 angle. Vortex weirs will be installed using local rocks with diameters greater than 30 in
 12 (76 cm) along the bed of the channel to achieve a grade line from the single lane bridge over the
 13 gulch near the canoe *halau* at the Hanakao’o Beach Park up to the highway.
- 14 2. Vegetation plantings: Bank stabilization and erosion protection will be accomplished in part
 15 using a combination of plants selected for erosion control, aesthetics, cultural value, and
 16 bioremediation. The channel banks will be planted with a variety of native plants adapted to
 17 the soil and hydrology of the site. Three zones of vegetation will be delineated on the banks
 18 of the channel: toe zone, from the intersection of the channel bed and banks 1 to 2 ft (0.3 to
 19 0.6 m) up the bank; middle zone, extending from toe zone up to the top of the banks; and
 20 upper bank zone, which includes the area from the top of the bank outward (planting
 21 distance outward will vary depending on site conditions). On banks comprised of large
 22 rocks (>12 in, 31 cm), plants will be installed in spaces between to the extent possible.

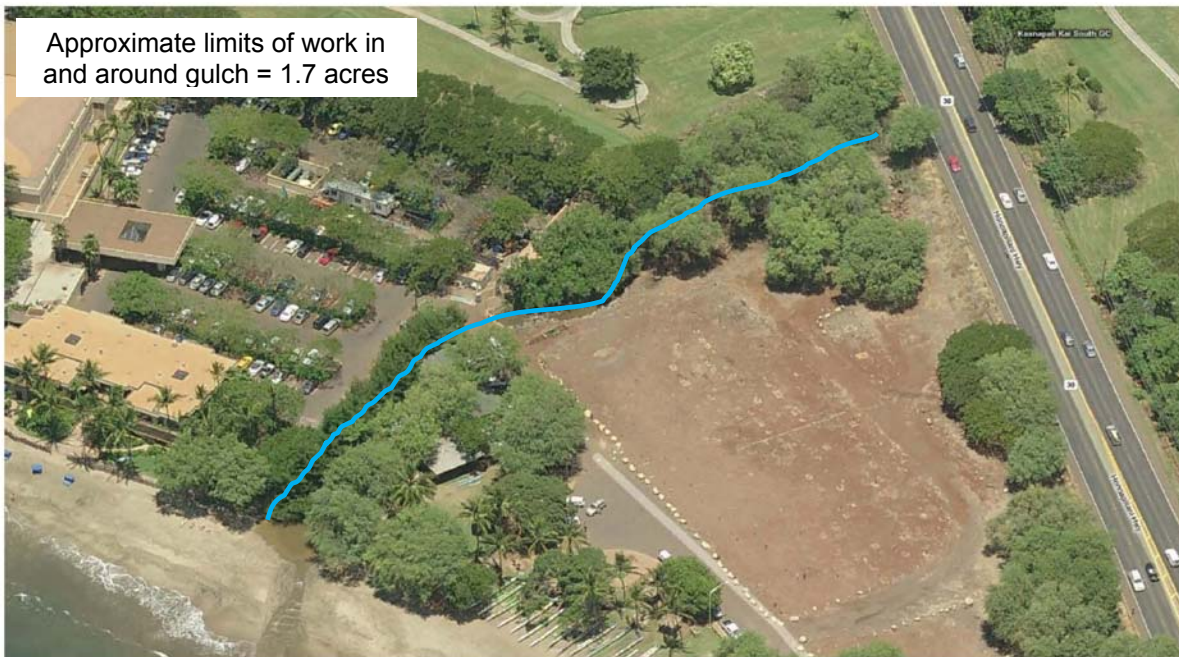

23
 24

Photo 4. Wahikuli Gulch

³¹ The use of concrete and other hardened treatments should be kept to a minimum and used only where necessary.

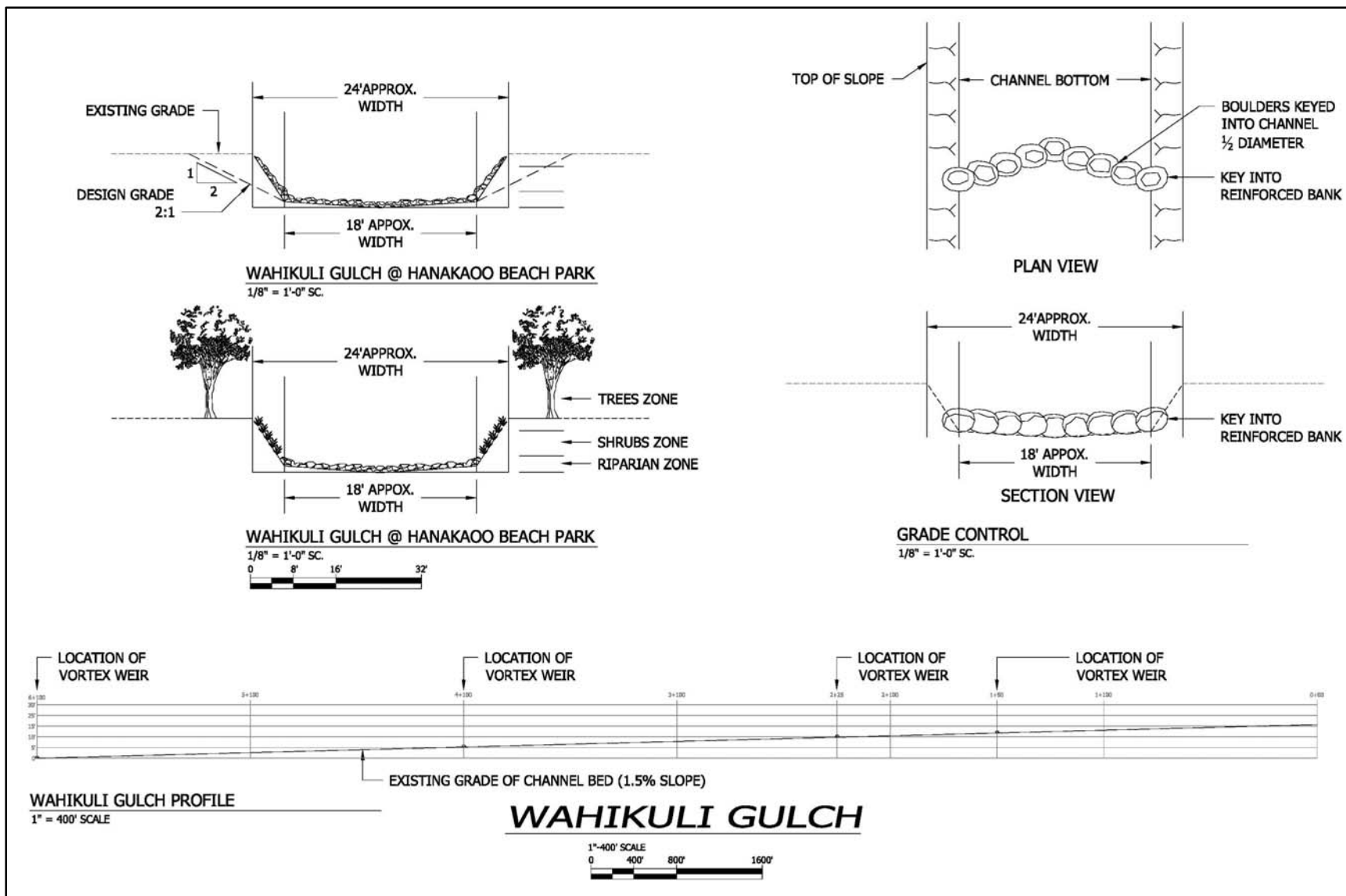

Figure 6. Conceptual Design for Wahikuli Gulch Stabilization

3. Channel liners: Synthetic channel lining fabrics will be installed on banks comprised of small unconsolidated surfaces (e.g. soil and fine rocks). Vegetation will be planted both under and in holes in the fabric to cover the liners. Channel liners will not be installed on banks comprised of large rocks.
4. Coir logs: Coir logs will be installed along the toe channel where loose and small particles exist and along banks and other surfaces where additional slope stabilization is needed or used to protect installed plants. Coir logs will be anchored with biodegradable stakes and/or tiebacks. Implementation

Estimated Cost

There are two cost components provided for planning purposes: engineering designs and estimated construction cost. The total cost estimated for both components is approximately \$344K. Table 11 details an order of magnitude cost estimate to prepare an engineering plan that includes plans, specifications, construction cost, and cost to prepare and acquire permits, for the conceptual level recommendations. A conservative approach was used to account for uncertainty in the number of permits and potential issues with right of entry. Table 12 provides an order of magnitude cost estimate for the construction component of the project. Construction costs were based on limited site information with respect to topography, and should be considered provisional until detailed designs are prepared.

Table 11. Cost Estimate for Developing Wahikuli Gulch Stabilization Detailed Engineering Design

Title	Rate/hr	Task (hr) Hydrology /Hydraulics	Task (hr) Engineering Design	Task (hr) Permits	Total Hours	Total Cost
PM	\$135	4	16	40	60	\$8,100
Engineer III	\$124	40	120	80	240	\$29,760
Engineer I	\$110	48	56	40	144	\$15,840
Environmental Specialist	\$88	16	32	160	208	\$18,040
Survey (topographic / property)	\$200	0	120	0	120	\$24,000
TOTAL		108	344	320	772	\$95,740

Table 12. Estimated Construction Cost for Wahikuli Gulch Stabilization

ITEM DESCRIPTION Wahikuli Gulch	QUANTITY		MATERIAL & LABOR UNIT COST	TOTAL COST
	TOTAL QTY	U/M		
Plants	1	LS		\$42,000
Coir logs	4,800	LF	\$9.80	\$47,040
Channel Liner	1,600	SY	\$8.00	\$12,800
Earth Work(excavation)	2,200	CY	\$12.20	\$26,840
Earth Work (grubbing and grading)	6,300	SY	\$9.80	\$61,740
Mobilization/Demobilization	1	LS	\$4,500	\$4,500
Irrigation	1	LS		\$23,000
Subtotal				\$217,920
Contingency 5%				\$10,896
HI GET (4.166%)	4.166%			\$9,532
TOTAL				\$238,348

1 Timeframe

2 A channel stabilization design for Wahikuli Gulch should be completed by 2016.

3 Responsible Entity

4 As the owner of most of the land within the project area, the County of Maui is responsible for any
5 improvements to Wahikuli Gulch. The Department of Public Works Highways and Engineering
6 Division and Planning Department would be involved.

7 Area Treated and Load Reduction Estimates

8 Wahikuli Gulch between Honoapi'ilani Highway and the ocean is approximately 650 ft (198 m) long
9 with average top width of 42 ft (12.8 m). This segment of the gulch carries water derived off
10 approximately 1,600 acres (650 ha) in the larger Wahikuli Watershed. A design to stabilize the bed
11 and banks in this segment is expected to reduce 80 percent of the sediment generated from within
12 the gulch segment. In addition, the stabilized channel would be expected to retain a portion of the
13 sediments and pollutants carried in runoff from the watershed area above the site. As a result the
14 stability of the channel would reduce a portion of sediment delivered off the watershed. With a
15 proper engineering design the channel would be less prone to floods, would enhance aesthetics of
16 the area, and reduce pollutant loads.

17 3.6 Fertilizer Management Plan**18 Problem Statement**

19 Fertilizers applied to agricultural fields, residential lots, and landscaped areas of resorts in amounts
20 that exceed plant uptake have the potential to leach through soils to ground water, or be flushed off
21 the ground surface in overland flow. In either scenario, fertilizers have the potential to reach the
22 ocean and elevate nutrient levels. In addition, fertilizers stored without adequate safeguards have
23 the potential to leak and inadvertently enter the environment.

24 A fertilizer management plan is a conservation practice recommended for any activities where
25 nutrients are actively applied, stored, and present the potential for introduction into the drainage
26 system. A fertilizer management plan can include information on timing, application rates, soil
27 moisture tests, and other pertinent information that results in the most effective use of fertilizer. It
28 is a comprehensive plan kept onsite at resort, golf course, industrial, and commercial facilities that
29 generate nutrient loadings during the normal course of operations that are potentially detrimental
30 to watershed health. Plans for agricultural fields should be created if not already in place, and
31 reviewed on a regular basis for efficiency and incorporation of changes in practices.

32 Objectives

33 The objective of developing and utilizing a fertilizer management plan is to minimize the amount of
34 nutrients that are lost due to leaching and surface runoff in order to reduce nutrient loads carried
35 to the ocean. This is accomplished by using specific, quantified fertilizer applications based on
36 specific site conditions. Fertilizers should be applied at minimum amounts needed by plants and at
37 times when the chance for wash off by rainfall is minimal. Judicious use of fertilizers should result
38 in reduced amounts applied on the watersheds and transported into the ocean.

1 **Recommended Actions**

2 Fertilizer management plans are recommended for both the Agricultural and Urban Management
 3 Units. Within the Agricultural Unit, this practice applies to the active fields. It is recommended that
 4 a plan be incorporated at all resorts, hotels, condominiums, businesses, and golf courses within the
 5 Urban Unit that actively maintain landscaped areas and apply fertilizers as a part of site operations.

6 ***Design Considerations***

7 A fertilizer management plan has several key components. Plans produced for agricultural lands
 8 within the Agricultural Unit should include at a minimum:

- 9 • Maps depicting land acreage, crop locations, existing soils, and waterbodies.
- 10 • Yield expectations based on achievable crop yields.
- 11 • A summary of onsite soil conditions and nutrient resources available. For the actively
 12 grown crops in the watersheds, this summary should include:
 - 13 ▪ Soil and/or plant tissue testing or historic crop yield response data.
 - 14 ▪ Nutrient analysis of manure or effluent applied on fields (as applicable).
 - 15 ▪ Irrigation water nutrient inputs.
 - 16 ▪ Other significant sources of nutrients.
- 17 • An inventory of hazards or concerns to incorporate into an evaluation of field limitations.
 18 For the actively grown crop fields in the watersheds, topics covered in this evaluation
 19 should include:
 - 20 ▪ Lava tubes.
 - 21 ▪ Shallow soils over fractured bedrock.
 - 22 ▪ Soils with high potential for leaching or runoff.
 - 23 ▪ Linear distance to surface water bodies.
 - 24 ▪ Soils with high erodibility.
 - 25 ▪ Shallow aquifers.
- 26 • The best available information for creating recommendations for crop nutrient sources and
 27 crop requirements.
- 28 • Identification of effective application methods and timing rates for nutrients including:
 - 29 ▪ Nutrient rates necessary for realistic crop yields.
 - 30 ▪ A reduction in nutrient losses to the environment.
 - 31 ▪ Avoidance of nutrient application during leaching and runoff periods.
- 32 • Soil erosion / sediment loss prevention practices.
- 33 • Proper calibration and operation provisions for the equipment used.

34 Plans produced for resort, hotel, business, and other professionally maintained lands within the
 35 Urban Unit should include at a minimum:

- 36 • Maps depicting total parcel size, turf/grass and landscape locations, existing soils, and any
 37 waterbodies onsite.
- 38 • A summary of onsite soil conditions and nutrient resources available to the site. This
 39 summary should include:
 - 40 ▪ Soil and/or plant tissue testing.

- 1 ▪ Nutrient analysis of reclaimed R-1 effluent applied (as applicable to specific properties
- 2 which utilize it).
- 3 ▪ Irrigation water nutrient inputs.
- 4 ▪ Other significant sources of nutrients.
- 5 ▪ Current fertilizer application rates and historical usage.
- 6 • An inventory of hazards or concerns to incorporate into an evaluation of site limitations.
- 7 Topics covered in this evaluation should include:
- 8 ▪ Lava tubes.
- 9 ▪ Shallow soils over fractured bedrock.
- 10 ▪ Soils with high potential for leaching or runoff.
- 11 ▪ Linear distance to surface water bodies.
- 12 ▪ Soils with high erodibility.
- 13 ▪ Shallow aquifers.
- 14 • The best available information for creating recommendations for turf and landscaping
- 15 nutrient sources and requirements.
- 16 • Identification of effective application methods and timing rates for nutrients including:
- 17 ▪ Nutrient rates necessary for establishment of healthy turf/grass and landscaping.
- 18 ▪ A reduction in nutrient losses to the environment.
- 19 ▪ Avoidance of nutrient application during leaching and runoff periods.
- 20 • Soil erosion / sediment loss prevention practices.
- 21 • Proper calibration and operation provisions for the equipment used.

22 **Implementation**

23 ***Estimated Cost***

24 Cost will vary based on size of property, type and variety of plants grown, and number of soil
 25 samples needed to accurately represent site conditions. For planning purposes a provisional cost
 26 estimate was derived based on a typical resort located in the Kā'anapali area with 10 acres of
 27 turf/grass (seashore paspalum) and landscaping comprised mixed shrubs and trees. A rough order
 28 of magnitude cost estimate to produce a fertilizer management plan is \$3k.

29 ***Timeframe***

30 Fertilizer management plans for Agricultural Areas should be completed by 2015. Fertilizer
 31 management plans for Urban Areas should be completed by 2016.

32 ***Responsible Entity***

33 The land owner is responsible for preparing a fertilizer management plan for their land. Targeted
 34 land owners include: KLMC, Ka'anapali Coffee Company (Coffee Farm), KOA (Ka'anapali Resorts),
 35 property owners and neighborhood associations (property owners and managers, with assistance
 36 from landscaping companies and Maui Association of Landscape Professionals).

37

1 **Area Treated and Load Reduction Estimates**

2 Area treated will vary based on the size of the parcel each plan is prepared for. Load reductions will
3 vary based on size of parcel and any decrease in fertilizer application as a result of plan
4 implementation.

5 **3.7 Burn Area Emergency Rehabilitation Plan**

6 **Problem Statement**

7 Stakeholders in the Conservation and Agricultural Units agree that wildfire threats are imminent
8 and can have widespread damage that potentially affects all properties within the Wahikuli and
9 Honokōwai Watersheds. Fire danger is related to the arid conditions and high fuel potential of
10 vegetation. Wildland fires have the potential to consume some or all of the vegetation within the
11 area they burn. Loss of vegetation to wildland fires often results in bare and exposed soils that are
12 vulnerable to erosion. The time it takes for burned areas to become re-vegetated and soils
13 protected varies based on rainfall rates, seed source, plant germination rates, and intensity of the
14 fire. In most areas of West Maui following a fire, vegetation that recruits into the burn area is
15 comprised of alien species that do not provide dense ground cover.

16 Concurrent to preparation of this WHWMP, regional land managers, land owners, and the Maui
17 County Fire Department are developing a *West Maui Fire Management Plan*. A fire management
18 plan typically defines levels of protection needed to ensure safety; protect facilities and resources;
19 and restore and perpetuate natural processes. This plan will address fuel loads, fire fighting tactics
20 and strategies, fire prevention, prescribed fires to reduce hazard fuel accumulation, logistical
21 operations, and other topics necessary to reduce occurrence, probability, duration, and intensity of
22 wildland fires across the West Maui region.

23 As part of the effort, certain dirt roads will be selected to function as fire fuel breaks. It is likely that
24 these roads will be widened to decrease the risk of fire spread and increase the effectiveness of the
25 breaks. It is strongly recommended that newly created fuel breaks or those created along existing
26 roads be fitted with management practices recommended for dirt roads.

27 **Objectives**

28 Reduce the risk of erosion and trap sediments within the burn area following a wildland fire.

29 **Recommended Actions**

30 Rehabilitation of natural areas in the aftermath of wildfire is part of comprehensive fire
31 management planning. A Burn Area Emergency Rehabilitation (BAER) plan is a component of post-
32 fire rehabilitation efforts and should be incorporated into the fire management plan for all lands
33 with the Agricultural and Conservation Districts currently being developed by West Maui
34 stakeholders. A BAER plan contains protocols and actions; identifies equipment, supplies, and
35 personnel necessary; and lays out logistical elements to implement erosion control strategies
36 immediately after a wildland fire. It should include the following components:

- 37 • Post-fire burn area rapid assessment and inventory (to determine areas where erosion
38 control and resource protection are needed).

- 1 • Description of burn area:
 - 2 ▪ A full description of the anticipated impacts the burn area will have on the coral reef.
 - 3 ▪ A full description of the area under study, including geography, cultural resources, fish
 - 4 and wildlife, vegetation, and structures/facilities within the area.
 - 5 ▪ Maps, photos, and supporting documentation of the area.
- 6 • Assembly of a planning team:
 - 7 ▪ The team is governed by an administrator.
 - 8 ▪ The team includes a standing or ad hoc group of technical or scientific specialists, either
 - 9 locally, regionally, or nationally based. This includes resource specialists
 - 10 (geomorphology, soils, hydrology, revegetation, wildlife, ecology, range, etc); members
 - 11 knowledgeable about post-fire impacts and effective rehabilitation techniques, and
 - 12 advisors.
 - 13 ▪ Team size and makeup is dependent on wildfire size, values to be protected,
 - 14 jurisdictions, and time frames involved.
- 15 • Tasks related to practices / supplies:
 - 16 ▪ Determination of availability and cost of supplies (e.g. seeds proposed for planting to
 - 17 establish revegetation).
 - 18 ▪ List of management practices (erosion and sediment control practices) to deploy at sites
 - 19 identified.
 - 20 ▪ List of suppliers of management practices.
 - 21 ▪ A suitable storage facility that can house the necessary management practices.
 - 22 - This will typically be a warehouse housing the fertilizer, seeds, and erosion and
 - 23 sediment control products necessary in proximity to the region.
 - 24 ▪ An inventory and details for placement procedure of erosion and sediment control
 - 25 management practices to protect resources (e.g. waterways, natural areas) from
 - 26 sedimentation in areas where fuel has burned off the landscape and left bare soil.
- 27 • Tasks related to equipment and labor:
 - 28 ▪ Availability and preliminary arrangements for mobilizing necessary equipment.
 - 29 ▪ Work force that can perform the management practice installations.
 - 30 ▪ List of governmental entities involved in potential fire fighting activities.
 - 31 ▪ Contact information for management or responsible party for implementing
 - 32 management practices.
 - 33 ▪ A description of the fire management team.
 - 34 ▪ Arrangements for cultural and threatened and endangered species consultations,
 - 35 including coordinating with agency specialists.
 - 36 ▪ Funding needs.

37 **Implementation**

38 ***Estimated Cost***

39 A rough order of magnitude cost estimate to produce a BAER plan is \$50k.

40 ***Timeframe***

41 A BAER plan should be completed by 2014.

42

Responsible Entity

Land owners in the Agricultural and Conservation Management Units (ML&P, KLMC, DHHL, GFG, State), along with the West Maui Mountains Watershed Partnership (WMMWP), the West Maui Fire Task Force, and the Hawai'i Wildfire Organization should be responsible for developing and implementing the plan.

Area Treated and Load Reduction Estimates

The area covered in the BAER plan will include all agricultural and conservation lands within the two project watersheds. It is not possible to estimate load reductions for a specific past fire. However, for discussion, a hypothetical fire with a contiguous burn area of 10 acres (4 ha), located on slope of 10 percent, with silty loam soil, which consumed 50 percent of the vegetative cover was estimated using RULSE2 to lose five tons of soil. It is reasonable to expect that erosion control practices installed following the fire but prior to rainfall events could trap approximately 80 percent of the sediment onsite, preventing nearly four tons from moving towards the ocean.

3.8 Baffle Box**Problem Statement**

The S4 is used to collect and convey storm water runoff generated off the urban areas of the watershed and discharge it into waterways that connect to the ocean or directly into the ocean. The S4 does not treat or otherwise remediate pollutants. As a result, pulses of pollutants are carried into ocean waters. S4 features (e.g. pipes and outfalls) located below the ground surface provide locations where treatment devices can be installed without interruptions or displacement to surface features. As urbanization continues, the amount of impervious area will increase along with storm water runoff and associated pollutants. In many areas that the S4 services space to install surface features (e.g. rain gardens) is limited. Retrofitting the S4 with treatment devices is a practical, though costly, approach to reducing land based pollutants.

The S4 along Lower Honoapi'ilani Road collects runoff and land-based pollutants that are discharged into an open channel that connect to the ocean at the south end of Honokōwai Beach Park. Space to install surface practices of any significant size is limited along the roadway and the numerous connected driveways and roads.

Honokōwai Beach Park sees high usage rates by locals and visitors alike. The presence of stores fronting Lower Honoapi'ilani Road attract both visitors and locals to the immediate area. Installation of a baffle box provides an excellent public education opportunity to bring awareness to urban area land-based pollution associated with coral reef decline. Permanent signage in "plain English" describing the project near the implementation location will help generate community support and promote the acceptance of future projects.

Objectives

Reduce loads of nutrient, total suspended solids (TSS), hydrocarbons, organics, and rubbish discharged into the open drainage channel that is connected to the ocean.

1 **Recommended Actions**

2 Baffle boxes are recommended for placement in the Urban District, placed inline within the S4 at
 3 various outfall locations along County roadways and in County beach parks and public parking lots
 4 (Figure 4 and Figure 5). The identified locations have a significant amount of contributing
 5 stormwater flow from upstream Urban Unit areas; are located near the outlet point of a County of
 6 Maui owned and maintained closed drainage system; and are in an area readily accessible to the
 7 public to increase awareness of the implementation of the practice. Baffle boxes should also be
 8 considered for installation as part of the future build-out of the S4. Main steps for installation of
 9 baffle boxes within the existing S4 include:

- 10 • Topographic survey in vicinity of proposed installation, completed by State of Hawai'i
 11 Licensed Land Surveyor.
- 12 • Hydrologic / hydraulic engineering analysis of site contributing drainage area, stormwater
 13 runoff calculations, and baffle box specifications, completed by State of Hawai'i Licensed
 14 Engineer.
- 15 • Installation of baffle box by qualified contractor.
- 16 • Long-term maintenance. The County of Maui Department of Public Works would be
 17 responsible for long-term maintenance of the baffle box, which includes:
 - 18 - Removal of trapped gross solids (e.g. rubbish, vegetative debris) within the unit's mesh
 19 grate.
 - 20 - Removal of settled particles within each of the three interior chambers.
 - 21 - Removal of pollutants absorbed onto the skimmer boom.
 - 22 - Clean out twice a year for a properly sized baffle box (depending on the number of
 23 runoff events).
 - 24 ○ Clean out with a standard vactor truck is approximately two hours per box.
 - 25 - Maintenance does not require hazardous materials training nor do workers need to
 26 enter the boxes' vaults.

27 Benefits of baffle boxes include:

- 28 - Storage volume is sized for drainage area.
- 29 - No loss of above grade or ground area.
- 30 - Box is below ground surface and not visible.
- 31 - Box has weep holes to allow water to drain after storm to prevent mosquito breeding.
- 32 - Boxes are not placed in streams or waterways and do not impair channel flows.

33 **Implementation**

34 ***Estimated Cost***

35 Costs for implementing a baffle box were based on lump sums estimates from equipment vendors
 36 and experience with preparing cost estimates for other Hawai'i locations. Costs include:

- 37 • Permitting costs as required (Maui County Department of Public Works)
- 38 • Topographic survey by licensed land surveyor (\$3,000 - \$5,000)
- 39 • Engineering design by licensed engineer (\$2,000)
- 40 • Baffle box construction (\$80,000)

- Baffle box lifetime maintenance (to be determined).

A rough order of magnitude cost estimate to install a baffle box is \$90k.

Timeframe

The installation of a baffle box above the S4 outfall at Honokōwai Beach Park should be completed by 2015. In the event the County determines that a baffle box is not warranted or is too costly, an alternative design should be developed. One potential alternative would be a constructed wetland in the channel located along the south side of Honokōwai Beach Park. At present the channel is in a degraded condition and holds stagnant water.

Responsible Entity

As the owner and operator of the S4, the County of Maui Department of Public Works is responsible for any improvements.

Area Treated and Load Reduction Estimates

Area treated will vary based on the location of the baffle box. Pollutant load removal efficiencies for baffle boxes are depicted in Table 13.

Table 13. Baffle Box Pollutant Removal Efficiencies³²

Constituent	Percent Removal
TSS	76.9 – 93.3
Total Phosphorus	18 – 70
Total Nitrogen	38 - 63
Metals	Up to 57
Trash and Debris	99

Priority Location

There is a series of catch basins and drain pipes that is part of the S4 running along the western edge of Lower Honoapiʻilani Road, adjacent to Honokōwai Beach Park and immediately in front of Boss Frog’s Dive and Surf and the West Maui Wellness Center. Placement of a baffle box inline within the existing S4 network on the *makai* shoulder of Lower Honoapiʻilani Road just downstream of the last catch basin before the southerly access driveway to the park is recommended. This location will allow the unit to receive and treat the maximum amount of inflow from upstream catch basins that capture runoff from a portion of the park’s parking lot as well as from Lower Honoapiʻilani Road. The location proposed for installation of the baffle box drains approximately 24 acres (9.8 ha), of which nearly 80 percent of are impervious surfaces. This location is also ideally located for generating public awareness regarding pollution abatement activities in the region through signage (Photo 5 and Photo 6).

³² Bio Clean Environmental Services, Inc. Nutrient Separating Baffle Box brochure, www.biocleanenvironmental.net.

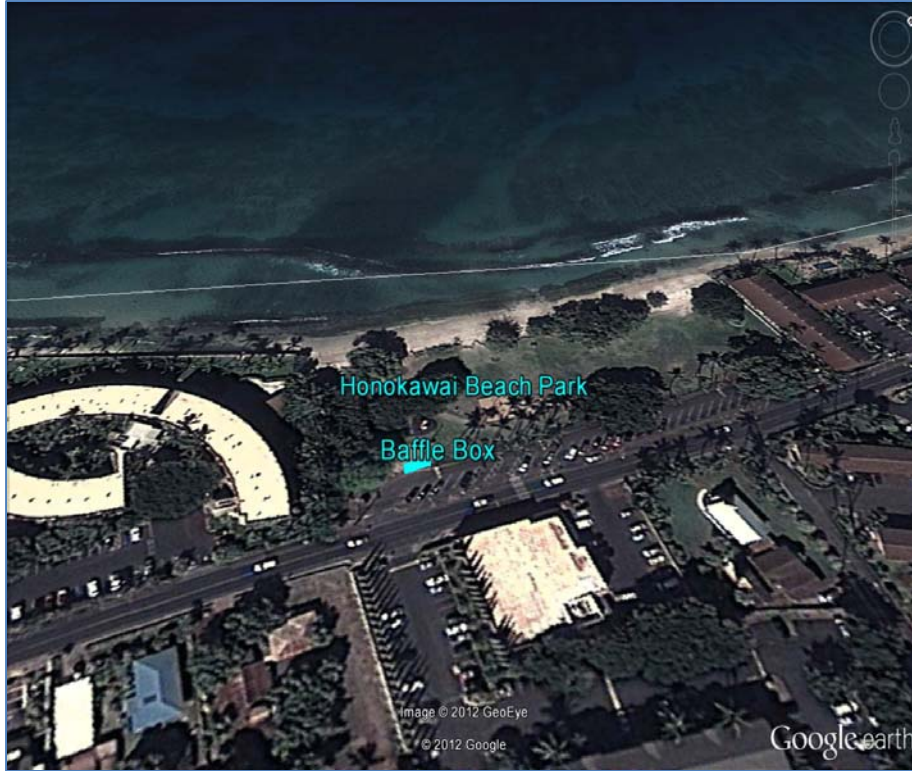

1
2

Photo 5. Baffle Box Location (aerial), Honokōwai Beach Park



3
4

Photo 6. Baffle Box Location, Honokōwai Beach Park

3.9 Bioretention Cells for Treatment of Surface Runoff

Problem Statement

Within the Urban District of Wahikuli and Honokōwai Watersheds, NPS pollutants such as hydrocarbons and metals from vehicles, nutrients, solids including sediments, and rubbish accumulate between storm events. Impervious surfaces that generate runoff and carry pollutants are located throughout the region. In locations where open space exists near impervious surfaces bioretention cells can be installed to intercept overland flow, improve quality of runoff, and attenuate runoff volumes.

Objective

Minimize pollutant runoff from impervious surfaces near the coastline by using natural features to collect and filter pollutants onsite.

Practice Locations

Bioretention cells are recommended for placement in proximity to areas within the Urban Unit that receive high traffic volume and low sediment loads (Figure 4 and Figure 5). Recommended locations for placement include within existing vegetated shoulders/lawn areas that abut parking lots. This includes public beach parks; resort parking lots; resort drop-off points, and along paved roads. Ideally, these areas should not be in the direct path of pedestrian traffic, as to avoid trampling of the cell. Existing grading of the site should be taken into consideration such that stormwater runoff can sheet flow directly from impervious areas into the bioretention cell without channelizing. Additionally, incorporating signage at a bioretention cell can provide an educational benefit, as many of the public are unfamiliar with the technology. It can also be seen as a selling point with tourists visiting the resorts in the area as many travelers are becoming more environmentally conscious and may appreciate that businesses in the area are helping to alleviate impacts to the coral reefs due to development. Exact placement will need to be conducted on a case-by-case basis, taking into account the volume of water generated on the impervious surfaces draining to the unit.

Resorts

The multitude of resorts along the coast gives ample opportunities to incorporate bioretention. Along the edge of parking lot pavement, or within parking lot islands between stalls and aisles are excellent choices for bioretention installation. The Sheraton Resort parking lot, located between the tennis courts and Kā'anapali Parkway just past the cul-de-sac, and the Westin Resort parking lot, located between the Westin Resort and Kā'anapali Parkway may be well suited for bioretention cells. Along Kā'anapali Parkway in level areas adjacent to the edge of pavement, where stormwater can sheet flow into the cell is also recommended. It is important to verify existing grades and to determine if stormwater will sheet flow off of paved areas naturally into the bioretention areas without bypassing or overloading the system.

Beach Parks

There are five beach parks along the coast of the two watersheds, which may be excellent locations for bioretention cell installation. From north to south, they are Pōhaku, Honokōwai, Kahekili,

1 Hanaka'ō'ō (Canoe), and Wahikuli Wayside Beach Park. All have parking lots adjacent to the public
2 access area.

3 While a detailed survey has not been performed at any of these sites, preliminary visual
4 observations conducted during the field reconnaissance phase of WHWMP indicate there is
5 potential for bioretention cell installation immediately adjacent to the beach park parking lots. Cells
6 can be placed on the downslope side of the parking lots, where existing lawn area abuts the
7 shoreline, or where picnic areas, or open space are currently. Incorporation of a grass filter strip
8 between the bioretention cell and the edge of pavement may be possible, if space allows, to improve
9 removal of sediment prior to stormwater entering the cell. It is important that runoff naturally
10 sheet flow into the cell without channelizing off of the impervious area.

11 **Recommended Actions**

12 Construction of bioretention cells (commonly known as rain gardens) is proposed for treatment of
13 parking lot runoff at two County beach parks (Wahikuli Wayside Beach Park and Pōhaku Beach
14 Park, commonly referred to as S-Turns Park). Hydrologically, a rain garden will reduce magnitude
15 of flows and increase travel time of water over the watershed to the ocean. Main steps include:

- 16 • Topographic survey, completed by State of Hawai'i Licensed Land Surveyor.
- 17 • Hydrologic / hydraulic engineering analysis of site contributing drainage area, stormwater
18 runoff calculations, and bioretention cell design, completed and stamped by State of Hawai'i
19 Licensed Engineer.
- 20 • Construction of bioretention cell by community-based organization or qualified contractor.
- 21 • Manual irrigation (as necessary) during first year of installation to establish healthy plant
22 stands.

23 **Priority Locations**

24 ***Wahikuli Wayside Beach Park***

25 Site Description

26 Wahikuli Wayside Beach Park is owned and operated by the County of Maui and is a local spot used
27 for recreational activities and barbecuing on the weekends, and to a lesser extent the weekdays.
28 The site consists of a small paved parking lot with approximately 24 parking stalls; a short access
29 driveway leading from Honoapi'ilani Highway into the site; an open grassy area with covered picnic
30 benches and barbeque grills; and a narrow, sandy beach.

31 Existing Conditions

32 The overall site slopes away from where it meets Honoapi'ilani Highway down to the shoreline.
33 Runoff generated on the parking lot and access driveway surfaces, and most likely a portion of the
34 highway, sheet flows across the strip of grass between the parking lot and shoreline. There is a
35 bituminous concrete curb that lines the *makai* edge of the parking lot, however breaks in the
36 curbing provide routing for stormwater to enter the grass strip. There are currently no practices in
37 place for treatment of pollutants contained in runoff generated at the site, although the grass strip
38 may provide some level of pollutant removal through natural infiltration.

1 Proposed Location

2 Photo 7 shows the proposed location of a proposed rain garden in Wahikuli Wayside Park.³³ The
 3 impervious cover draining to the rain garden is a total of 3,677 ft² (342 m²) and includes the
 4 parking lot, half of the bathhouse roof, and the shower pad. Stormwater will flow from the parking
 5 lot through three existing curb cuts into stone-lined swales to reduce erosion before finally entering
 6 the rain garden. Water from the shower will also be directed into the rain garden, which will help
 7 keep the plants watered during extended dry periods. For large storm events, water will overflow
 8 the rain garden, into the existing shower drain and outfall. The rain garden will not pond water for
 9 more than 24 hours, will be planted with low maintenance native plants, and will have educational
 10 signage for park users. This rain garden will not impede on maintenance since the existing access
 11 path appears to go around the shower and bathhouse. Figure 7 depicts a conceptual design for the
 12 rain garden.



13

14

Photo 7. Wahikuli Wayside Beach Park Rain Garden Location (Not to Scale)³⁴

³³ This rain garden has been designed by Horsely Witten Group, Inc. and is planned for installation as part of a workshop.

³⁴ Area shown for placement is approximate.

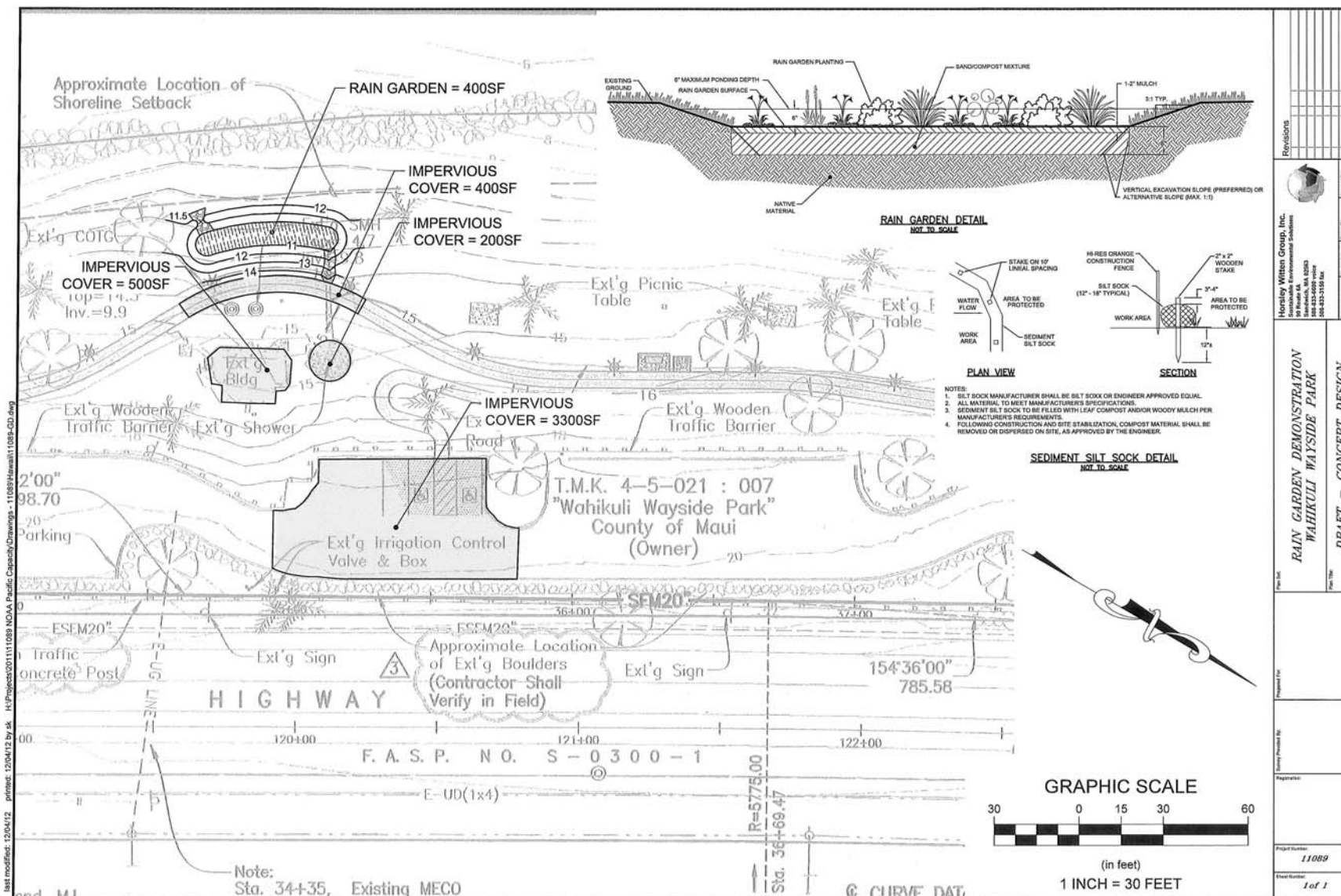

Figure 7. Conceptual Design for Rain Garden at Wahikuli Wayside Park

1 **Pōhaku (S-Turns) Beach Park**

2 Site Description

3 Pōhaku Beach Park (commonly referred to as S-Turns Park) is owned and operated by the County
 4 of Maui and is a local hotspot for surfing and recreation on the weekends, and to a lesser extent the
 5 weekdays. The site consists of a T-shaped paved driveway that provides access from Lower
 6 Honoapi'ilani Road, and terminates in two small parking lots with unlined stalls, to the north and
 7 south. The northern parking lot can accommodate approximately seven vehicles, while the
 8 southern parking lot can accommodate approximately five vehicles. Additionally, vehicles
 9 frequently parallel park along the access driveway. There are open grassy areas within the park as
 10 well as benches and picnic tables and an outdoor shower at the southern end of the park. A small,
 11 sandy beach is also available for recreation at the southern end of the park.

12 Existing Conditions

13 A high point exists in the access driveway near the "T" point where the driveway splits. This point
 14 directs runoff either to the northern or southern portion of the site. Runoff generated on surfaces
 15 north of this point drains across the access driveway, the northern parking lot, and nearby grassy
 16 area before discharging into the ocean. Runoff generated on surfaces south of the high point flows
 17 down the access road and across the small southern parking lot and grassy area before reaching the
 18 outdoor shower at the southern end of the park. Accumulated rainfall runoff and overflow from the
 19 shower drains from this point across the grass and into the ocean.

20 Lower Honoapi'ilani Road runs parallel to Pōhaku Beach Park and is crowned along its full length. It
 21 consists of two lanes, with a paved, striped shoulder on both sides of the road. Lower Honoapi'ilani
 22 Road slopes downward in the southern direction, and runoff generated within the *makai* lane and
 23 shoulder runs along the pavement/grass interface until it reaches the southern end of the park.
 24 Road runoff flows across the park's grassy area as well as the gravel area at the bottom of the hill
 25 where Pohakuka'anapali Gulch (channelized and hardened) flows under the road and discharges
 26 into the ocean. There are currently no practices in place for treatment of pollutants contained in
 27 runoff generated on the park driveway or parking lot surfaces, nor for runoff generated on this
 28 section of Lower Honoapi'ilani Road. The grass areas at the northern and southern ends of the park
 29 may provide some level of natural pollutant removal through infiltration, although the degree of
 30 which is unknown.

31 Proposed Location

32 The bioretention cell will capture runoff from impervious areas that lie south of the driveway high
 33 point, including the driveway itself and the full southern parking lot, as well the *makai* lane and
 34 shoulder portion of Lower Honoapi'ilani Road that drains to the southern end of the park (Photo 8).
 35 The cell should be constructed within the grass area at the southern end of the site, in the vicinity of
 36 the outdoor shower area, south of the southern edge of the parking lot. The grass area between the
 37 edge of the parking lot and the edge of the bioretention cell will allow for pretreatment (capture) of
 38 sediments contained in parking lot runoff prior to entering the cell.

1

Photo 8. Pōhaku Beach Park (Not to Scale)³⁵



2

Implementation

Estimated Cost

Costs for implementing one location of a bioretention cell include:

- Special Management Area (SMA) permit, Maui County.
- Topographic survey by licensed land surveyor including shoreline certification required for work performed within shoreland area (\$7,500 - \$10,500)
- Engineering design by licensed engineer (\$3,000)
- Bioretention cell construction (\$10,000 - \$15,000). Volunteer and community efforts will reduce implementation costs. Includes use of mini excavator or hand shovels.

Total Design and Construction Cost: \$20-30k.

Timeframe

Installation of the bioretention cells should be completed by the end of 2015.

15

³⁵ Area shown for placement is approximate; existing site utility locations have not been verified.

1 **Responsible Entity**

2 The land owner is ultimately responsible for the installation and long-term maintenance of
3 bioretention cells. In the case of the beach parks, the bioretention swales may be constructed by the
4 County or by private entities with the permission of the County Department of Parks and
5 Recreation. It may be possible to enlist volunteers to adopt a rain garden and provide the necessary
6 maintenance.

7 **Area Treated and Load Reduction Estimates**

8 Photo 7 and Photo 8 show recommended bioretention cell locations at Wahikuli Wayside Beach
9 Park and Pōhaku Beach Park. The locations are presented as representative examples of possible
10 installations and contributing drainage areas treated within beach parks.

11 The proposed bioretention cell in Wahikuli Wayside Beach Park receives and treats a drainage area
12 of approximately 10,500 ft² (975 m²). The proposed bioretention cell in Pōhaku Beach Park
13 receives and treats a drainage area of approximately 16,000 ft² (1,486 m²). Typical pollutant load
14 reductions resulting from installation of bioretention cells can be seen in Appendix A.7, Table A.6.

15 **3.10 Low-Impact Development Strategies for Future Development**

16 A Low Impact Development (LID) management practice is a stormwater management strategy
17 concerned with maintaining or restoring the natural hydrologic functions of a site to achieve
18 natural resource protection and maintain water quality while meeting environmental regulatory
19 requirements and minimizing a project's impact. LID practices utilize a variety of natural and built
20 features that reduce the rate of runoff, filter out pollutants, and facilitate the infiltration of water
21 into the ground. LID management practices help to improve the overall quality of receiving surface
22 waters and stabilize the flow rates of nearby streams.

23 For existing developments, management measures and practices serve several purposes:

- 24 • Minimize and reduce introduction of pollutants into the environment.
- 25 • Control pollutants at their source.
- 26 • Reduce pollutant loadings in surface water runoff in developed areas.
- 27 • Minimize sediment loadings from stream banks and other natural conveyance features, by
28 reducing volume and velocities of runoff.
- 29 • Preserve, enhance, or establish buffers that create benefits to water quality along
30 waterbodies and their tributaries.

31 In most existing developments and built areas within a watershed, practices to control runoff and
32 land-based pollutants are added as retrofits to conventional storm water systems or onto other
33 features. Management practices can provide these same purposes in future developments, but also
34 have the advantage of incorporating low impact design controls into the design phase, rather than
35 retrofitting a developed site. Addressing water quality and placing controls on pollution generation
36 during the design phase of a project can represent a cost savings over the life of the project, when
37 compared to future retrofits that may be required to address pollutant issues. LID can also
38 represent a significant reduction in disturbed and impervious areas associated with a project (e.g.
39 utilizing natural areas for detention and treatment of stormwater runoff in lieu of standard large
40 detention ponds).

1 Of the recommendations made in this WHWMP, bioretention cells and vegetated swales are two
2 low impact designs that are cost effective and feasible for use in future developments. Additional
3 LID practices that should be encouraged in the West Maui region though not specifically
4 recommended in this WHWMP include, but are not limited to, permeable surfaces (e.g. concrete or
5 asphalt); residential and commercial green roof systems; and clustered residential development
6 layouts to minimize impervious areas and development areas in sub-divisions in lieu of
7 conventional lot layout. The most effective method for ensuring the incorporation of LID strategies
8 into future development is to require their use through policy and regulatory requirements (e.g.
9 building codes, permit requirements), primarily at the County level (Section 5.5).

10 There are multiple future development projects proposed for Wahikuli and Honokōwai
11 Watersheds. These projects include a range of single family, multi-family, and timeshare/hotel unit
12 developments.³⁶ Future development projects are identified by the County of Maui according to
13 their approval status, zoning entitlements, and Community Plan designation. Some of the
14 management practices that currently apply to lands within the Agricultural Management Unit may
15 no longer apply upon completion of the future development projects slated for that region.³⁷ It will
16 be necessary to select new practices that apply to the development uses of the land on a project-
17 specific basis, as some developments will be agricultural subdivisions, while others will be urban in
18 nature and incorporate facilities and landscaping. Use of LID should be adopted and included in
19 designs by all developments regardless of size or scale of the project (e.g. single family residential,
20 large multi unit developments, commercial centers).

21

³⁶ For more information on the designation, scope, and number of units proposed for each of the development projects proposed in the project area, see Section 3.3.3 of *Volume 1: Watershed Characterization*.

³⁷ See *Volume 1: Watershed Characterization*, Sections 6.7.2 and 6.7.3 for a discussion on the transition of lands from Agricultural to Urban as the result of future development and the associated impacts to NPS pollution.

4. Evaluation and Monitoring

The *Evaluation and Monitoring* section provides guidance for evaluating the progress of program implementation and measuring performance of management practices in meeting the plan's vision and goals. This is critical to determining the success of a watershed planning effort and to securing additional funding. Before implementation gets too far underway, the watershed coordinator and working group should establish a formal tracking and monitoring program.

4.1 Measuring Effectiveness of Watershed Management Planning

Evaluating the success of watershed management planning efforts is important. Successful program implementation is demonstrated when management practices are being implemented in areas identified, in a timely fashion, cost-effectively, etc. The effectiveness of management practices is measured by achieving reductions in pollutant loads into the waterways and related improvements to the health of the coral reef environment.

4.1.1 Program Implementation

Development of an implementation strategy requires selecting practices, securing funds, establishing timescales, and planning tasks. Target timeframes can be assigned to management practices as a means to support scheduling and track tasks. EPA suggests outlining tasks and the level of effort for each to establish a baseline for time estimates. It is also necessary to collectively discuss tasks and identify those that are feasible and identify the responsible parties (EPA 2008b). Factors such as funding availability, participation of managing and regulatory entities, and effectiveness of pollutant load reduction will influence feasibility of management practice implementation and the implementation timeline. As the implementation process moves forward, additional work will be needed to fund the efforts and distribute work requirements. An implementation strategy for education and outreach activities is presented in Section 4.3.5.

The principles of adaptive management require regular review of the program and revision of management goals, objectives, actions, and techniques, to improve the performance of the program. The WHWMP is a living document that will benefit from regular review and updating, to remain current and to support effective management. The WHWMP should be reviewed (yearly) and updated (as needed) regularly. Future reporting and results of monitoring activities will be essential to providing information on the pollutant loads in the watershed and the effectiveness of management practices. This WMP will serve as a template for other WMPs being addressed by the West Maui R2R Initiative. Lessons learned from the process of developing the WHWMP will be applied to subsequent watershed management planning efforts in the region.

4.1.2 Management Practice Performance

To ensure the most effective pollution control strategies for Wahikuli and Honokōwai Watersheds, the success of management practices to limit generation and transmission of pollutants in the watersheds must be regularly evaluated. Regular monitoring must occur in order to determine if progress is being made towards meeting stated goals. A status report should be developed by the watershed coordinator every year to document progress, challenges, and next steps. Next steps will consist of a list of priority management practices to occur the next year, along with a realistic schedule that reflects available funding, equipment purchases, and personnel time. Comparison of

1 the projected schedule with the actual schedule will enable better timeline estimates for future
 2 projects and will help determine if the scale and scope of the management practices slated for the
 3 following year(s) are appropriate.

4 Information in the GIS and associated databases will be essential for developing this report so data
 5 can be objectively analyzed and compared between years. Notes on problems encountered with
 6 management practices, interesting outcomes, successes, and ideas for improving management
 7 practices in the future should be kept on a linked document, to allow for easy cross-reference.

8 **4.1.3 Pollution Reduction Targets**

9 Ideally, a WMP should identify specific targets for load reductions of identified pollutants (i.e.
 10 sediment). The practical reality of the WHWMP is that there is limited baseline water quality data
 11 available from project area sources (e.g. groundwater wells, natural stream channels, nearshore
 12 environment) over a consistent historical basis for use in establishing specific reduction targets. It
 13 will be difficult to quantify specific pollution reduction targets for Wahikuli and Honokōwai
 14 Watersheds without this information.

15 However, monitoring can be conducted to evaluate whether management practices are reducing
 16 NPS pollutants (e.g. sediments captured by the installed structures). There is a need to address both
 17 the current lack of available information and ongoing monitoring to set targets and measure
 18 progress towards reducing pollutant loads. Indicators will provide quantitative measurements of
 19 progress toward meeting goals and will be easily communicated to target audiences. The indicators
 20 and associated targets will serve as triggers to indicate whether progress is being made and
 21 whether the implementation approach needs to be reevaluated. It is important to note that often,
 22 long and uncertain lag times occur between implementation and response at the watershed level.
 23 This timing is accounted for in the evaluation and monitoring framework.

24 **4.1.4 Performance Metrics**

25 Performance metrics can be used to evaluate progress towards meeting each of the watershed goals
 26 (Table 14). These example metrics can be refined over time.

27 **Table 14. Example Metrics for Evaluating Progress towards Meeting Watershed Goals**

Watershed Goal	Metric
Measurably reduce rates of erosion and sediment loads generated on dirt roads, fields, and along waterways in the agricultural and urban areas of Wahikuli and Honokōwai Watersheds and carried to the coral reefs by 2017.	<ul style="list-style-type: none"> - Measured improvements in water quality - Length of roads inventoried and treated with erosion control practices - Area of fields inventoried and treated with erosion control practices - Number of management practices installed - Development and implementation of BAER plan
Measurably reduce fertilizer loss and nutrient loads generated from residential and resort properties and agricultural fields of Wahikuli and Honokōwai Watersheds and carried to coral reefs by 2017.	<ul style="list-style-type: none"> - Measured improvements in water quality - Number of fertilizer management plans developed and implemented
By maximizing reuse, decrease the amount of treated wastewater effluent from the Lahaina Wastewater Reclamation Facility injected into the ground and transported to the ocean by 2023.	<ul style="list-style-type: none"> - Length of new R-1 service lines installed - Number of users with access to R-1 water - Amount of R-1 water diverted from injection

Watershed Goal	Metric
Provide effective guidance to ensure implementation and long-term success of watershed management efforts in Wahikuli and Honokōwai Watersheds by 2014.	<ul style="list-style-type: none"> - Participation in watershed working group - Regular review and update of WHWMP - Use of WHWMP as a model for other WMPs - Establishment and implementation of a monitoring program
Increase education, understanding, and participation by both residents and visitors regarding watersheds, non-point source pollution, and coral reef health in Wahikuli and Honokōwai Watersheds by 2017.	<ul style="list-style-type: none"> - Dollars spent on education and outreach - Number of volunteers participating in outreach activities - Installation of demonstration restoration projects - Number of attendees participating in site visits/workshops to discuss retrofit and other restoration projects - Number of public and private landowners participating in WHWMP efforts

1 **4.2 Monitoring Logistics**

2 **4.2.1 Drivers for Monitoring**

3 Monitoring is conducted for both regulatory and non-regulatory purposes, although in many cases
 4 it is driven by regulations even if the regulation itself does not “require” monitoring.

5 **Water Quality**

6 Section 208 of the 1972 CWA requires every state to establish effective practices to control NPS
 7 pollution. Also, under CWA Section 303(d), the EPA requires that each state develop a list of waters
 8 that fail to meet established water quality standards. Waters on the §303(d) list of impaired water
 9 bodies are defined as water bodies having beneficial uses but that are impaired by one or more
 10 pollutants. The law requires that states establish priority rankings for waters on the list and
 11 develop Total Maximum Daily Loads (TMDL) for these waters.³⁸ In many cases, the recognition of
 12 CWA §303(d) listing and the subsequent development of TMDLs for that water body triggers a
 13 water quality monitoring program.

14 Honokōwai Stream, and various water bodies within the Wahikuli and Honokōwai Watersheds are
 15 on the §303(d) list of impaired water bodies (*Volume 1: Watershed Characterization*, Section 5.3).
 16 Each of the water bodies is listed as medium priority (on a scale of low, medium, high) for initiating
 17 TMDL development based on prioritization criteria and resource availability. However, TMDLs
 18 have not yet been initiated by the State DOH. All water bodies in the State are required to adhere to
 19 water quality standards, however, most streams are not routinely sampled and determining if a
 20 stream is compliant with standards is difficult. The development and implementation of a WMP
 21 may preclude the need for a TMDL, while achieving the same endpoint, reduction of NPS pollutant
 22 loads and attainment of water quality standards.

23 **Coral Reef Health**

24 As a priority site for the Hawai’i Coral Reef Strategy, watershed management efforts in the West
 25 Maui Region are targeted at improving the overall health of coral reefs, nearshore waters, and

³⁸ A TMDL is a calculation of the maximum amount of a pollutant that a water body can receive, also known as the loading capacity, so that the water body will meet water quality standards. The TMDL allocates that load to point and non-point sources, which includes both anthropogenic and natural background sources of pollutants.

watersheds (*Volume 1: Watershed Characterization*, Section 1.1). As a key partner in this effort, the NOAA Coral Program uses a set of performance measures to track progress toward reaching on-the-ground outcomes in addressing threats from LBSP (Box 6) (NOAA Coral Reef Conservation Program 2012). Monitoring efforts conducted as part of and in relation to the WHWMP will assist NOAA in gathering the information needed to demonstrate progress. Although the WHWMP does not include monitoring of coral reefs, there are related efforts to assess coral reef health over time (Section 4.3.1).

Box 6. NOAA Coral Program’s LBSP Performance Measures

- | |
|--|
| <ol style="list-style-type: none"> 1. Number of watersheds with completed and approved integrated WMPs. 2. Number of projects completed from approved WMPs to reduce LBSP in priority coral reef areas. 3. Stable or decreasing total suspended solids (metric tons/year) measured in target watersheds. 4. Stable or improving coral demographics (recruitment, size frequency, mortality) in priority coral reef areas. 5. Number of in-water restoration projects implemented in degraded coral reef ecosystems to reduce accumulated sediments, nutrients, and algae. 6. Number of active partnerships established with local, state/territory, federal and/or non-governmental organizations with a common goal to reduce LBSP impacts in priority coral reefs areas. |
|--|

4.2.2 Monitoring and Data Collection Responsibility

At present there is no single entity responsible for collecting and maintaining data and information on water quality and/or watershed conditions in Wahikuli and Honokōwai Watersheds. Watershed and stream resources in West Maui have been studied by a range of public and private entities including University of Hawai’i researchers, State and Federal agencies, and non-governmental organizations (*Volume 1: Watershed Characterization*, Section 5.4 and Appendix D). Each of these efforts contributes valuable information to support monitoring efforts. Studies that do not have a monitoring component can provide essential baseline information about watershed condition. Past monitoring efforts provide data for comparison and determination of effectiveness.

The WHWMP characterizes the watershed conditions and makes recommendations on how to reduce NPS pollutants generated from the watershed and discharged into the ocean. This is an essential first step towards improving the health of the watershed and its receiving waters. However, there is still a need to develop a monitoring program that can provide baseline data and numeric criteria to evaluate the expected changes of water quality following implementation of some or all of the recommended management practices.

There needs to be an identified entity conducting baseline monitoring in the watershed, even if not required. Similarly, monitoring the effectiveness of the practices once they are installed is not necessarily required under the CWA, but should be conducted. As the entities ultimately responsible for ensuring successful implementation of the WHWMP, it is recommended that DLNR-DAR and the West Maui Watershed Working Group play a role in figuring out who should take the lead on collecting, managing, and analyzing the information recommended as part of monitoring for Wahikuli and Honokōwai Watersheds.

4.2.3 Data Collection, Storage, and Reporting

Identifying specific approaches for accurate collection and analysis of data is essential for determining the effectiveness of implemented management practices. General guidance on water

1 monitoring to be conducted by volunteers is available in *Taking Care of Hawai'i's Waters: A*
 2 *Guidebook for Getting Started in Volunteer Water Quality Monitoring*.³⁹ Monitoring stormwater
 3 management practices tends to generate a considerable amount of data and information. A well
 4 designed and implemented data management program is valuable for the development of
 5 comprehensive and ongoing monitoring of management practices (Appendix D.1).

6 In order to maximize the effectiveness of data and information collected, and to increase its
 7 exposure and usefulness to larger stakeholder groups, a central repository should be developed to
 8 house the data collected by the various parties. A geo-database for Wahikuli and Honokōwai
 9 Watersheds and/or the greater West Maui Region should be developed and maintained.
 10 Collaboration with past efforts and building onto existing databases would be an efficient means for
 11 utilizing GIS in monitoring efforts.

12 **4.3 Monitoring in Wahikuli and Honokōwai Watersheds**

13 Monitoring is a process that provides feedback to managers and stakeholders to verify if pollution
 14 control strategies are being installed and working as designed, and if water quality is improving.
 15 Some level of monitoring is necessary to verify and justify the installation of practices and provide
 16 support for future installation of management practices. Of the seven types of monitoring used in
 17 watershed management, this plan focuses on four: trend, implementation, baseline and
 18 effectiveness (EPA 1997) (Table 15; Appendix D.2). These four types best address the intent of the
 19 *Evaluation and Monitoring* requirements and will provide the necessary information to determine if
 20 NPS pollutant reduction is occurring in Wahikuli and Honokōwai Watersheds. Monitoring also
 21 helps to refine future selection of practices for other watersheds.

22 **Table 15. General Characteristics of Monitoring Types**

Type of Monitoring	Location of Monitoring	Frequency of Measurements	Duration of Monitoring	Intensity of Data Analysis
Trend	Reference Site	Low	Long	Low to moderate
Baseline	Installation & Reference Site	Low	Short to medium	Low to moderate
Implementation	Installation site	Variable	Duration of project	Low
Effectiveness	Installation & Reference Site	Medium to high	Usually short to medium	Medium
Project	Variable	Medium to high	Greater than project duration	Medium
Validation	Installation & Reference Site	High	Usually medium to long	High
Compliance	Installation Site	Variable	Dependant on project	Moderate to high

23 The overall goals of implementing stormwater management practices pertain to preventing
 24 pollution at the source, improving stormwater outfall discharge quality, reducing pollutants loads
 25 to receiving waters, restoring ecosystem functions for beneficial uses and erosion protection, and
 26 complying with water quality standards. The priority parameters that monitoring of Wahikuli and
 27 Honokōwai Watersheds will focus upon are 1) fine terrigenous sediments, 2) nutrients, and 3)
 28 other land-based NPS pollutants.

³⁹ http://monitoring.coral.org/sites/default/files/documents/Water%20Quality%20Manual_Final_10_2.pdf

4.3.1 Trend Monitoring

Trend monitoring is used to measure improvements in water quality and coral reef health over time. As practices to reduce land-based pollutants are implemented, it is expected that marine life will respond positively, resulting in a positive trend. While the WHWMP does not specifically call out parameters for trend monitoring, on-going activities will provide information to assess water quality and coral reef health. Trend monitoring is being conducted for shoreline water quality (DOH-CWB Beach Monitoring Program, with comparisons to State water quality standards) and coral reef health (DLNR-CRAMP Surveys). The CRAMP long-term monitoring is conducted to describe the spatial and temporal variation in Hawaiian coral reef communities in relation to natural and anthropogenic forcing functions. CRAMP surveys have and will continue to be conducted in the Kā'anapali Region. CRAMP monitoring efforts should be expanded to the coral reefs off Wahikuli Watershed, including marginal reef areas. When conducted prior to or concurrent with any implementation projects, monitoring will help to demonstrate the effectiveness of these efforts over time. Development of accurate benthic habitat maps should be a priority for the off-shore areas of both Wahikuli and Honokowai Watersheds as an additional component of monitoring reef health.

Robert Richmond (Research Professor, University of Hawai'i at Mānoa, Pacific Biosciences Research Center, Kewalo Marine Laboratory) is developing biomarkers to determine exposure of coral reefs to pollutants. These genetic markers can indicate when a coral has been exposed to a pollutant even if the substance is no longer present in the coral's tissue, making them useful for trend monitoring. The biomarker methods are being used to assess coral reef response to reductions of specific land-based pollutants in the Kā'anapali Region.

Long-term trend monitoring of water quality and coral reef health can be used in conjunction with the efforts to monitoring implementation and effectiveness of the management practices recommended in the WHWMP, with the idea that installation and maintenance of management practices will, over time, reduce NPS pollutant loading to streams and off-shore systems, resulting in improved quality. This type of monitoring aligns with NOAA Coral Program's LBSP Performance Measures 3 and 4 (Box 6).

4.3.2 Baseline Monitoring of Environmental Conditions

In general, water quality data for Wahikuli and Honokōwai Watersheds is sparse and/or lacking, making the development of numerical estimates on the concentration of pollutants in runoff and groundwater challenging. Management units were delineated in order to focus on NPS pollutant types and control methods within the State Land Use Districts. Monitoring methods to collect baseline information that address the identified priority NPS pollution parameters in the Agricultural and Urban Management Units are identified in

Table 16.⁴⁰ Establishing baseline sampling (reference) sites across the management units will provide data and information that can be used for baseline and trend monitoring. Trend monitoring can supplement effectiveness monitoring and can be used to correlate the management practice installation and trends in water quality, watershed condition, and coral reef health.

⁴⁰ Monitoring in the Conservation Management Unit is addressed in the WMMWP Management Plan.

1

Table 16. Baseline Monitoring Parameters

Monitoring Location	Monitoring Objective	Method
Agricultural Management Unit		
Fallow fields	Estimate sediment loss.	Measure surface area, establish photo points, establish erosion pins
Dirt access roads	Inventory condition to determine specific locations for broad based dips and water bars to reduce sediment production.	Ground based survey of road and trails, establish photo points, establish erosion pins
Māhinahina, Honokōwai Streams above dam; Wahikuli Stream above highway	Determine baseline water quality, use for long term trend monitoring.	Collect and analyze water samples at routine intervals
Exposed surface soils	Determine percent ground cover, estimate exposed field surface area, and potential sediment loss.	Establish photo points, establish erosion pins
Urban Management Unit		
Collect water samples at stormwater pipe outfalls within Honokōwai Stream, coastal outfalls	Determine baseline water quality of stormwater runoff, can be used for long term trend analysis and identifying pollutant hotspots to remediate.	Collect grab samples during runoff events and analyze at lab.
Resorts and hotels, throughout residential and commercial areas.	Determine attitudes and views of stakeholders; assess willingness to alter behavior to reduce generation of NPS pollutants.	Survey a subset of residents to determine activities and uses that generate NPS pollutants.
Seeps near Kahekili Beach Park	Evaluate water quality, macro algae, and coral over time	Use methods currently employed by various researchers and government entities.

2 **4.3.3 Implementation Monitoring**

3 For each management practice installed in the Wahikuli and Honokōwai Watersheds, the following
 4 information should be collected and maintained in a GIS database and/or relational database.
 5 Information on implementation should be conveyed to County of Maui, DOH, DLNR-DAR, DOT,
 6 NOAA, USACE, U.S. Geological Survey, and other entities to be determined.

- 7 - Details on specific type of management practice
- 8 - Management unit
- 9 - Location installed
- 10 - Construction start date
- 11 - Construction completion date
- 12 - Entities involved
- 13 - Purpose and targeted pollutants
- 14 - Expected performance (if applicable)
- 15 - Issues and delays before implementation (if applicable)

4.3.4 Effectiveness Monitoring of Management Practices

Once management practices are installed, effectiveness monitoring should be conducted. Information on effectiveness monitoring for each management practice, including the objective(s) of monitoring efforts, basic monitoring protocols, and recommended monitoring frequency, is included in Appendix D.3. Results of effectiveness monitoring should be maintained in a GIS database and/or relational database.

Although a monitoring frequency of a set interval (for example, every six months or annually) is advantageous with respect to planning and resource efforts, the most beneficial data is usually obtained in inclement weather, typically during or after a rainfall event of significant intensity that tests the management practice under conditions for which it was designed. Due to potentially high variability of discharge and pollutant concentrations in Wahikuli and Honokōwai Watersheds, collecting accurate and sufficient data from a significant number of storm events and base flows over a range of conditions (e.g. season, land cover) is important. Developing a monitoring plan that is flexible with respect to weather patterns is a recommendation to gain insight into which practices require maintenance or replacement with a more suitable management practice (Box 7).

Box 7. Stormwater Quality Monitoring Challenges

Stormwater quality at a given location varies greatly both among storms and during a single storm event. Significant temporal and spatial variability of stormwater flows and pollutant concentrations are challenging to effectively sample. For example, the intensity of Hawai'i's rainfall varies seasonally and is often irregular and dramatic. Variations in rainfall affect the rates of runoff, pollutant wash-off, in-channel flow, pollutant transport, sediment deposition and resuspension, channel erosion, and numerous other phenomena that collectively determine the pollutant concentrations, pollutant forms, and stormwater flow rate observed at a given monitoring location at any given moment. The arid environment of both the Agricultural and Urban Management Units also presents challenges with respect to stormwater quality monitoring. In addition, the transitory and unpredictable nature of many pollutant sources and release mechanisms (e.g. spills, leaks, dumping, construction activity, landscape irrigation runoff, vehicle washing runoff) contribute to inter-storm variability (GeoSyntec and ASCE 2002). In general, many measurements (i.e. many samples taken during a single storm event) are necessary to obtain enough data to be confident of actual management practice performance. Available resources, such as budget and staff, should be considered when determining the number of samples required to obtain a statistically valid assessment of water quality. A well-designed monitoring program will need to collect enough stormwater samples to result in a high level of statistical confidence when determining management practice effectiveness. A small number of samples are not likely to provide a reliable indication of stormwater quality at a given site or the effect of a given management practice.

4.3.5 Additional Studies to Fill Data Gaps

Monitoring is also conducted in the context of conducting studies to determine causative factors. Two additional studies (baseline monitoring) are recommended as priority in the Wahikuli and Honokōwai Watersheds to evaluate unknowns.⁴¹

Coral Toxicologic Assessment

Monitoring coral reef health is critical in order to better understand what environmental variables are causing the corals to decline. Refining these relationships will provide information that can be used to better inform management decisions and direct resources to address causes of reef decline. This includes determining what are the impacts to coral health are from various toxins and other chemicals. Monitoring efforts are essentially studies that are necessary to understand the baseline environmental conditions of the coral reef ecosystem. There are still unknowns as to how coral respond to different chemicals under varying concentrations and exposure time. Assessing these

⁴¹ These studies should be higher priority than effectiveness monitoring of management practices.

1 responses with new scientific techniques will aid in identifying potential sources of chemicals that
 2 are adversely impacting corals and implementing practices to remediate the sources. Researchers
 3 such as Dr. Robert Richmond use coral biomarkers to assess individual coral response to chemicals.

4 **Groundwater and Solute (Pollutant) Transport and Fate Modeling**

5 The volume of groundwater and the discharge locations along the shorelines and as submarine
 6 groundwater in Wahikuli and Honokōwai Watersheds is unknown. Groundwater data is limited to a
 7 few monitoring wells with temporal gaps in data that are primarily located in the middle elevations
 8 of the watersheds. Over time, groundwater can transport a variety of solutes (pollutants) to ocean
 9 waters. Modeling groundwater and the flow paths, concentrations, and transport rates of various
 10 chemicals (both known to exist and potentially existing) in the aquifers will provide information on
 11 total loads delivered to ocean waters that is currently not available. This is necessary to better
 12 understand the role and impact groundwater has on the health of the coral reefs and develop
 13 remedial strategies.

14 **4.4 Summary of Evaluation and Monitoring Recommendations**

15 Monitoring results will inform an adaptive management approach to implementing the WHWMP
 16 (Section 2.4). A comprehensive monitoring program to support implementation is needed. DLNR-
 17 DAR and the West Maui Watershed Working Group should work to identify one or more
 18 responsible entities.

19 **Table 17. Evaluation and Monitoring Recommendations**

Recommended Action	Priority
Establish a formal mechanism for tracking progress and results, particularly for programmatic activities, priority projects, and environmental conditions. <ul style="list-style-type: none"> - Identify entity to collect, manage, and analyze information - Engage community groups in monitoring activities - Incorporate results of related efforts to monitor long-term trends in water quality and coral reef health 	High
Establish and use performance metrics to evaluate progress toward meeting watershed goals.	High
Develop and maintain geodatabase to organize monitoring information. ⁴²	Medium
Conduct trend monitoring of coral reef health.	High
Conduct baseline monitoring for primary pollutants (sediments, nutrients).	High
Conduct implementation monitoring to document progress in conducting projects and practices.	Medium
Conduct effectiveness monitoring (Appendix D.3)	Low
Conduct additional studies to fill data gaps	Medium

20

⁴² Scope could be for Wahikuli and Honokōwai Watersheds and/or the greater West Maui Region.

5. Education and Outreach

The *Education and Outreach* section describes strategies to educate and engage people in reducing NPS pollution in Wahikuli and Honokōwai Watersheds including: building public awareness and support, supporting implementation, engaging the community, and changing policy. In addition, this section includes an explanation of the organizational structure in place to assist in finding, funding, and synergizing on education and outreach initiatives. Strategies presented in this section are aimed at meeting Goal 5: *Increase education, understanding, and participation by both residents and visitors regarding watersheds, non-point source pollution, and coral reef health in Wahikuli and Honokōwai Watersheds by 2017* (Box 2).

Lack of education or awareness of water quality impacts is a root cause of many NPS pollution issues. Successful implementation of the WHWMP, including the recommended management practices, is dependent on stakeholder awareness and involvement. Some landowners exposed to information and education campaigns will change their practices based on a greater awareness of water quality issues. This can be expected to improve and/or maintain water quality and coral reef health. Education and outreach programs should:

- Increase stakeholder awareness about the link between LBSP and coral reef ecosystem health.
- Increase stakeholders' level of knowledge about nutrient and sediment loading and the health of the off-shore waters.
- Educate land use decision makers.
- Increase agency support for, and participation in, actions to reduce NPS pollution.
- Engage the community in installation, monitoring, and maintenance of projects.
- Convey information about monitoring activities and results.
- Involve partnering with other groups to develop and implement a comprehensive education and outreach program addressing water quality, watershed management, and coral reef health issues.
- Develop targeted outreach activities and materials.
- Affect policy change.

5.1 Build Public Awareness and Support

An education and outreach strategy needs to build community support for a holistic approach to planning for the Wahikuli and Honokōwai Watersheds, and West Maui in general. This includes developing general public awareness about polluted runoff, including its negative effects on coastal and marine environments including coral reefs. Educational outreach on pollution prevention should be conducted to inform stakeholders how they can reduce generation of NPS pollutants and discharges to the receiving ocean waters. Efforts also need to target implementation of structural and non-structural management practices identified in the WHWMP. Watershed awareness and active stewardship among residents, community associations, businesses, and visitors can be promoted through education programs, recreational opportunities, and participatory watershed activities (Section 5.3).

1 **5.1.1 Key Themes and Messages**

2 For all levels of stakeholder interaction, the West Maui R2R Initiative, in which the WHWMP is
 3 included, has a set of key themes and messages to communicate the basic aspects of the project:
 4 who, what, why, where, how, and when. This provides the framework for understanding the larger
 5 context and intent in which specific educational efforts are nested. The key themes, and the
 6 messages relative to each, are as follows:

7 Coral reefs are declining in many parts of Hawai'i

- 8 • In West Maui, nearly one-fourth of all living corals have been lost in the last thirteen years
 9 alone.
- 10 • Without dramatic steps to restore favorable conditions, reefs statewide risk rapid
 11 degradation.

12 Healthy watersheds and coral reefs are vital to our island lifestyle, economy, and a thriving Native
 13 Hawaiian culture.

- 14 • Healthy watersheds recharge and purify our water resources, preserve biodiversity and
 15 protect the land and ocean from storm damage.
- 16 • Healthy reefs provide abundant fish for sustenance, recreation and tourism, protect
 17 shoreline during storms and keep Maui a world class destination.
- 18 • Healthy watersheds and reefs improve resilience to the effects of climate change.
- 19 • Coral reefs support complex food systems, diverse biological life, recreation, commerce, and
 20 shoreline protection.
- 21 • Coral reefs are integral to the rich spiritual and cultural heritage of the Hawaiian Islands
 22 and their people.

23 The goal of the R2R Initiative is to restore and enhance the health and resiliency of West Maui coral
 24 reefs and nearshore waters through the reduction of land-based pollution threats from the summit
 25 of Pu'u Kukui to the outer reef.

- 26 • The initiative was triggered when the area was locally and nationally designated as a
 27 priority because of rapidly declining reef health.
- 28 • The initiative area extends from Kā'anapali northward to Honolua and from the summit of
 29 Pu'u Kukui to the outer reef. The area includes five watersheds: Wahikuli, Honokōwai,
 30 Kahana, Honokahua, and Honolua.

31 The R2R Initiative, of which the WHWMP is one component, is a collaborative effort.

- 32 • The initiative builds off of already established efforts underway and leverages resources
 33 across agencies and community groups to implement actions to reduce LBSP.
- 34 • The small, discrete actions that we have been doing to date must now evolve into a more
 35 comprehensive plan of action. Reducing LBSP is one of the single most important steps to
 36 help restore coral reef ecosystems.
- 37 • A number of partners have come together to work collaboratively to address and reduce
 38 impacts to West Maui's coral reefs: NOAA, NRCS, EPA, and NFWF.
- 39 • DLNR and USACE are co-funding the R2R Initiative, while NOAA is funding the WHWMP.
- 40 • The initiative will coordinate resources among county, state and federal agencies.

- The initiative will ensure that the process, on-the-ground actions, and lessons learned can be transferred to, and replicated in, watersheds in other island communities.

The R2R Initiative and the WHWMP are focused on land-based pollution, a key source of reef decline.

- The islands and reefs are connected; what we do on land affects the reef.
- LBSP include erosion, compounds found in fertilizers and pesticides, human waste, urban runoff and many other sources.
- Increased sedimentation associated with loss of forest land, historical agriculture practices, stream channelization, and rapid development has impacted coral reef health.
- LBSP cause reef decline by increased nutrient loading and smothering the coral from increased amounts of sediments settling on the coral.

The outcome of the R2R Initiative, beginning with the steps taken with the WHWMP, will be community and partner organization based actions to reduce land-based pollution in near-shore waters.

- The initiative will include activities that agencies, organizations, and the community can undertake to restore coral reefs.
- Strategies will include prioritized actions for community and group implementation.
- Grant funds from several sources may be available to address the initiative’s priorities.
- Recommended practices are voluntary with no regulatory requirement.

5.2 Organizational Support for Implementation and Outreach

By virtue of being a component of the R2R Initiative, there is a broad base of support for the goals of the WHWMP from four teams, which in working together, form the organizational structure covering plan management and funding, to advisory and implementation functions. These elements are the Watershed Coordinator, the FAST, the West Maui R2R Working Group, and the West Maui R2R Hui. These components are described in more detail below, and among other functions, provide the structure to support educational and outreach activities.

5.2.1 Watershed Coordinator

A West Maui Watershed and Coastal Management Coordinator was hired in March 2012. The Coordinator is tasked with assisting in comprehensive planning for the West Maui Project Area with a focus on building community networks that include the working group, the Hui, and stakeholders. The internal communications function of the Watershed Coordinator is to be the on-the-ground coordinator furthering the goals of the West Maui R2R Initiative by convening and facilitating the working group, coordinating the needs of the Hui to keep forward momentum, and functioning as a conduit for information between the FAST, working group, and Hui. This role also includes taking the lead on outreach and education efforts for the initiative, increasing impact by working in partnership with the FAST, the Hui, and the working group to achieve the communication objectives above.

1 **5.2.2 FAST and Other Agency Support**

2 The West Maui R2R Initiative is managed, funded, and directed by the FAST, which is led by USACE
 3 and DLNR-DAR, and includes NOAA, DOH, EPA, FWS, USGS and NRCS (Section 2.2). This multi-
 4 agency approach is essential in that the actions needed to target LBSP and nearshore ecosystem
 5 health cannot be addressed by a single agency. In addition to the support from the FAST,
 6 engagement with the County of Maui and other agencies facilitates integration of improved water
 7 quality management practices into existing agency management plans and practices. Key to these
 8 efforts will be the ability to secure funds for implementing management solutions.

9 **5.2.3 West Maui R2R Working Group**

10 The West Maui R2R Working Group was established in June 2012. It is a DLNR-chaired working
 11 group that is facilitated by the Watershed Coordinator. The working group includes representation
 12 from recreational users, land owners, agricultural operations, cultural representatives,
 13 environmental groups, natural resource conservationists, visitor industry, and Maui County
 14 representatives. These individuals represent the diversity of main uses and interests in the Wahikuli-
 15 Honokōwai Region. The working group is a vehicle for ensuring regular, timely stakeholder input
 16 into the WHWMP and the R2R Initiative strategy development, via the FAST. In addition, it will
 17 propose and champion implementation projects and assist in the dissemination of information back
 18 to the respective interest groups, as well as assist with tracking and monitoring of progress.

19 **5.2.4 West Maui R2R Hui**

20 Participating at the level of project implementation, including education and outreach, research,
 21 support, and action planning is the West Maui R2R Hui. The Hui includes all governmental agencies,
 22 non-profits, community groups, individuals, businesses, landowners, etc. who are taking action
 23 towards the goals of the West Maui R2R Initiative. This can take the form of projects, data
 24 collection, or other products such as reports or studies. Examples of engaged entities contained in
 25 the West Maui R2R Hui include the County of Maui via various departments, The Nature
 26 Conservancy, and the University of Hawai'i. The number of entities in the Hui is expected to grow
 27 throughout the life of the project as more organizations become involved in implementing
 28 activities, conducting outreach, or providing educational opportunities to the community.
 29 Engagement at the Hui level does not preclude involvement with the working group or FAST.

30 **5.3 Engage the Community**

31 Community engagement focuses education, enforcement, and technical resources on changing
 32 behaviors that cause pollution. Specific resources applied to different target audiences are selected
 33 based on major pollutant source areas identified in a watershed. Pollution prevention and source
 34 control education is a broad restoration practice that seeks to prevent pollution by targeting
 35 stakeholders. Public engagement is key to success as implementation of recommendations will, in
 36 part, be accomplished through community projects (Table 18).

1

Table 18. Potential Projects for Community Members

Type	Tasks	Notes
Bioretention Cell (Rain Garden)	Design, permitting, installation	Planned rain garden workshop will provide community members with a starting point for developing additional installations
Illicit Dumps	Debris removal, signage	Community sponsored clean-up May require coordination with County to dispose of items
Good Housekeeping Practices	Various, to reduce generation of NPS pollutants and runoff; includes LID strategies	See Appendix C.5 for details
Gutter Downspout Disconnection	Physical manipulation of infrastructure on residential properties	Requires appropriate location for infiltration
Natural/Native/Drought Resistant Vegetation	Vegetation planting	Encourage use of native, dryland species in residential landscaping
Monitoring	Water quality sampling, coral reef surveys	Should be conducted as part of an overall plan for the area to insure that quality data is obtained.
Policy	Work with government agencies to develop and achieve policy changes	Rules governing the management of stormwater for new and redeveloped lands

2 **5.3.1 Outreach Tools and Methods**

3 A range of stakeholder interaction methods and tools are typically needed to reach and engage the
4 full range of stakeholders as effectively as possible. Recognizing that the values and interests of
5 project stakeholders may vary, different methods are needed to meet the needs of the stakeholders,
6 as well as to facilitate the flow of information back and forth between the stakeholders and the
7 project team. The range of methods that will be utilized by the R2R Initiative includes small-group
8 meetings, public meetings, outreach at events, a project website, listserv, news articles, and a
9 social marketing campaign. General tools to be incorporated within these methods include the use
10 of photos, maps, social media and educational signage. In addition, EPA has developed a *NPS*
11 *Outreach Toolbox*, which contains a variety of resources to help develop an effective and targeted
12 outreach campaign to educate the public on NPS pollution or stormwater runoff.⁴³ Examples from
13 Hawai'i and the mainland can be adapted for use in West Maui. The following details how specific
14 outreach methods and tools will be used.

15 **5.3.1.1 R2R Initiative Outreach**

16 **Small Group Meetings**

17 Small-group meetings will be conducted to obtain input and guidance from key stakeholders, as
18 needed, to help inform and guide the project development process, as well as create buy-in for
19 recommended practices. To allow for free exchange of information, the small-group meetings will
20 generally be limited to approximately 10-15 people, and held in a location that is convenient and
21 accommodating to the most number of participants. This format would be used with stakeholders
22 or Hui participants with discrete interests.

⁴³ <http://cfpub.epa.gov/npstbx/index.html>

1 **General Public Meetings**

2 General public meetings are used as a tool for sharing and gathering information specific to the
3 stage of the planning efforts. Public meetings were held to share the content and collect input on
4 the WHWMP.⁴⁴ These meetings are broadly announced to promote maximum participation and
5 input by the public. Additional public meetings will be scheduled, with the input of the FAST, to
6 facilitate the R2R Initiative three year planning process. These meetings will also provide
7 opportunities to share updates on implementation actions from the WHWMP.

8 **Outreach at Related Events**

9 The watershed coordinator will staff a table with resources at marine and environmental events
10 along with partner entities such as Makai Watch, who often participates in outreach events related
11 to reef health and ocean stewardship. Developed collateral will assist in the effectiveness of this
12 approach.

13 **Website**

14 A website was established to inform stakeholders about the WHWMP, key findings, and meetings,
15 and to provide a way of receiving input. Transitioning into the future, a project website has been
16 developed by the Hawai'i Coral Reef Strategy that is available for public viewing.⁴⁵ The information
17 on the website is intended to provide historic and current project information in a format that is
18 understandable to the full range of stakeholders. Information contained on the website includes a
19 location map, project background and history, links to project related documents, details about
20 upcoming project meetings and events, and a “get involved” button that is directed to the
21 watershed coordinator. In addition, the website will allow users to submit project-related
22 comments electronically to the project team. The website will be periodically updated to reflect
23 progress or changes in the project status: www.kaanapaliwmp.com (until Winter 2012).

24 **Listserve**

25 Given that the activities of the West Maui R2R Initiative will take place over three years and the
26 implementation actions of the WHWMP will take place over a similar time frame, it is appropriate
27 to use an email list to share project progress and to solicit participation. This will include
28 newsletter updates two to four times per year, meeting announcements, and announcements for
29 material available for public review or edification.

30 **News Articles**

31 As a means to continue momentum and maintain visibility of the initiative and WHWMP progress,
32 periodic news releases or feature stories will be submitted to the Maui News. Given the ongoing
33 activities of the Hui, there are many stories worth sharing.

34 **Social Marketing Campaign**

35 Working closely with SeaWeb, a non-profit organization specializing in sharing scientific
36 information with the public in a compelling way, a strategic communications and marketing plan
37 that supports the outreach goals of the WHWMP and the overarching West Maui R2R Initiative will
38 be developed. In cooperation with the community and locally based organizations, a campaign will

⁴⁴ The public meeting for Volume 2 of the WHWMP is scheduled for October 2012.

⁴⁵ <http://www.hawaiicoralreefstrategy.com/index.php/prioritysites/westmaui>

1 be organized around the most effective way to drive behavioral change that will improve watershed
 2 health. This process involves several steps including assessing the landscape, market research,
 3 developing a strategy, identifying gatekeepers, engaging partners, designing tactics, and executing
 4 the plan. A campaign could include multiple forms of media, such as video, radio, social marketing
 5 or other methods that engage and inspire the desired audience.

6 **5.3.1.2 Potential Outreach Tools**

7 **Workshops**

8 In partnership with other groups, the R2R Hui could provide workshops on topics specific to the
 9 various aspects of watershed planning and ridge to reef stewardship. This could be educational
 10 sessions aimed at increasing the capacity of the community members in ways that could prime
 11 them for joining the Hui, or providing an educational opportunity for those already engaged.
 12 Potential topics include: effective grant writing, water quality monitoring techniques, and K-12
 13 watershed curriculum. Landowners who attend targeted workshops (e.g. pollution control
 14 strategies) would be expected to come away with increased awareness of how their land
 15 management decisions impact water quality and many will change their current practices.

16 **West Maui Ridge to Reef Fairs**

17 An annual fair in July could be organized in coordination with the Makai Watch Kahekili Birthday
 18 Bash to raise community awareness, mobilize support and involvement, recruit new participants,
 19 and promote best management practices (BMP) and games with the themes of reducing pollution
 20 and restoring reefs.

21 **Colloquiums**

22 The Hui could stay updated on participants' activities through bi-annual colloquiums, or an
 23 informal meeting that will include presentations or seminars from Hui participants and an
 24 exchange of views relating to the West Maui R2R Initiative. These meetings could take place in
 25 public venues and all West Maui R2R partners would be invited along with the general public. Guest
 26 speakers who have been successful with watershed restoration efforts in other areas could be
 27 invited to speak, sharing their stories and lessons learned. Talk story sessions could also be
 28 included, such as inviting Hawaiian practitioners to teach traditional management techniques
 29 based on an *ahupua'a* or *moku* (types of land division systems).

30 **5.3.2 Suggested Educational Topics for Increasing Community Watershed Stewardship**

31 Pollution prevention and source control education is about more than just raising awareness,
 32 although this is an important component. In the Kā'anapali Region, opportunities exist to help
 33 stakeholders practice better stewardship. Much of the region is privately owned and effective
 34 private stewardship of those watershed areas is an integral part of watershed protection. Efforts
 35 should focus on discouraging pollution-producing behaviors and implementing practices or
 36 programs that will help to reduce pollution. By working in partnership with the R2R Hui or other
 37 partners, specific behaviors and activities that can be targeted across the watershed include:

- 38 • Improving lawn care and landscaping practices
 - 39 - Educate land owners on practices to reduce fertilizer and pesticide use on their lawns.
 - 40 - Encourage an increase in native plant landscaping and edible organic gardening.

- 1 - Encourage smaller lawn area.
- 2 • Disconnecting rooftops
- 3 - Install rain barrels, rain gardens, and naturally vegetated depression areas that accept
- 4 rooftop drainage.
- 5 • Improving control of erosion
- 6 - Provide better guidance and enforcement of on-site erosion. Also, provide education on
- 7 appropriate landscaping techniques.
- 8 • Increasing watershed awareness
- 9 - Implement stream buffer awareness signs and create an adopt-a-gulch program to keep
- 10 gulches clean (could include maintenance of contributing roads).
- 11 - Implement storm drain stenciling throughout the Urban District, so the public
- 12 understands “All drains lead to the ocean”. Stenciling the drains can be expected to
- 13 result in increased awareness of landowner impacts to surface water. This should result
- 14 in a change in practices that will improve and maintain water quality.
- 15 - Organize seasonal waterway clean-up days for neighborhoods, by watersheds or *moku*
- 16 (district).
- 17 - Create a ‘reef friendly’ certification program for businesses and/or landowners (e.g.
- 18 coral reef friendly coffee).
- 19 • Managing recreational activities
- 20 - Partner with resorts to educate staff and visitors about potential for damaging coral
- 21 reefs (i.e. humans can easily damage delicate corals by standing on, kicking, or coming
- 22 in contact with them).
- 23 - Work on reducing off-road dirt bike use in the upper portions of the watersheds (e.g.
- 24 use bike shops as a potential avenue).
- 25 - Educate landowners and event organizers on the environmental impacts of insufficient
- 26 restroom facilities and encourage better planning for needed infrastructure to reduce
- 27 negative impact on water quality.
- 28 • Improving municipal responsibility
- 29 - Local governments maintain much of the physical infrastructure in the watersheds,
- 30 including roads, sewers, and storm drain systems. In many cases, communities can
- 31 reduce or prevent pollutants from entering the watershed by changing their
- 32 infrastructure maintenance policies.

33 **5.4 Watershed Management Activities**

34 **5.4.1 Examples of Ongoing Efforts by the West Maui R2R Hui**

35 The WHWMP is one part of a larger watershed-based management planning effort in West Maui
 36 that involves multiple entities and projects that are carried out by entities that form the R2R Hui.
 37 Some of these projects are focused on research, others on planning, and still others on
 38 implementation. Although specific goals and objectives may differ, the overarching vision of
 39 protecting the ecosystem, from ridge to reef, is consistent. Related efforts are detailed in *Volume 1:*
 40 *Watershed Characterization*, Section 1.2. The WHWMP directly and indirectly integrates with these
 41 other efforts as described below.

1 The **West Maui R2R Plan**, being undertaken as part of the West Maui R2R Initiative, will use the
 2 WHWMP as a guide in developing a WMP for three additional watersheds in West Maui: Kahana,
 3 Honokahua, and Honolua.

4 The **West Maui Mountains WMP** is being developed by the WMMWP primarily for the
 5 Conservation lands in the West Maui Mountains. This WMP will complement the WHWMP by
 6 providing management strategies for watershed protection and NPS pollution control in the upper
 7 elevations of Wahikuli and Honokōwai Watersheds. A representative from the WMMWP is a
 8 member of the West Maui R2R Working Group, ensuring coordination of efforts.

9 The **Kahekili Conservation Action Plan (CAP)** used a strategic planning process to outline broad
 10 strategies to address existing and future threats to coral reef ecosystems in the region. The strategic
 11 actions outlined in the CAP provide an overarching framework for more detailed management
 12 plans (i.e. WHWMP, West Maui Mountains WMP), responsible entities, and implementation
 13 activities.

14 The **West Maui Soil and Water Conservation District (WMSWCD)** is the main resource for
 15 technical assistance in managing agricultural lands. WMSWCD will play a key role in identifying
 16 problem areas and helping to design and support implementation of solutions to control NPS
 17 pollution. Some of the management practices outlined in the WHWMP may be eligible for funding
 18 under the U.S. Department of Agriculture-NRCS West Maui Coral Reef Initiative (*Volume 1:*
 19 *Watershed Characterization*, Section 1.2). WMSWCD is assisting with the first implementation
 20 project in the Agricultural District aimed at reducing the erosion from roads starting at the end of
 21 2012.

22 **Maui County** has outlined future development plans for the West Maui region (*Volume 1:*
 23 *Watershed Characterization*, Section 3.3.3). The WHWMP provides recommendations for LID
 24 strategies designed to reduce NPS pollutant generation as lands are converted to different uses. In
 25 addition, the WHWMP supports the findings of the Maui Wastewater CWG to increase usage of R-1
 26 water for irrigation, thereby reducing the amount of wastewater injected into the WWRF wells
 27 (Maui DEM 2010).

28 The **Coral Reef Alliance (CORAL)** is an international organization, working in several locations,
 29 including Hawai'i, to save coral reefs by engaging stakeholders and linking sustainable business
 30 practices and community-based conservation. CORAL has been selected to receive NFWF funding to
 31 work with hotels in the West Maui region beginning Fall 2012 to increase their understanding
 32 about the benefits of using R-1 water and ensure they are actively seeking efforts to reduce potable
 33 water usage and increase water reclamation.

34 The **NOAA Hawaiian Islands Humpback Whale National Marine Sanctuary** staff based in
 35 Kā'anapali have a volunteer base that is engaged in outreach and education as well as potentially
 36 citizen science activities (e.g. water quality monitoring) in the near future.

37 **Makai Watch** provides regular outreach and education opportunities related to ocean stewardship
 38 in West Maui and are therefore natural partners. Efforts may be specific to the WHWMP or may
 39 address the goals of the larger initiative. Where possible, efforts will be coordinated to develop and
 40 implement a comprehensive education and outreach program addressing water quality and

1 watershed management issues. Documenting progress in establishing and maintaining partnering
 2 efforts provides information to support NOAA Coral Program’s LBSP Performance Measure 6 (Box
 3 6).

4 **5.4.2 Educational Opportunity: Pilot Projects**

5 It is important to involve the community in implementing ‘green infrastructure’ and other early
 6 opportunity demonstration projects. Concurrent to WHWMP development, the NOAA Coral Program
 7 is funding installation of a rain garden at Wahikuli Wayside Park based on input from the Maui
 8 participants in the Pacific Island Watershed Institute workshop in June 2011 (Section 3.9). Other
 9 funds from the NOAA Coral Program have been earmarked for implementing priority
 10 recommendations from the WHWMP through the Hawai’i’s Coral Reef Conservation Grant (Section
 11 2.2). These projects, some of which will be high-visibility NPS-reduction pilot projects, will provide
 12 opportunities for local residents and business owners to observe and/or participate in installation
 13 and maintenance. Volunteers will be recruited to assist both with installation and outreach for the
 14 projects. Periodic site visits/tours will be provided and progress updates will be circulated (Section
 15 5.3.1).

16 **5.5 Change Policy**

17 Most, if not all, of the recommendations presented in the WHWMP will be implemented on a
 18 voluntary basis; they are not required by rules or regulations. Adoption of policy at the County or
 19 State level provides developers and landowners with a standard set of guidelines designed to
 20 address limiting production of stormwater or treating NPS pollutants. The County of Maui is
 21 moving in this direction, and is finalizing new rules governing the management of stormwater for
 22 new and redeveloped lands. Additional management practices are proposed to increase the
 23 effectiveness of LID implementation. It is suggested that regardless of the regulatory and permit
 24 requirements, that all developments of all sizes adopt LID designs.

25 **5.5.1 Proposed County of Maui Rules for Stormwater Treatment**

26 Currently, the County of Maui Department of Public Works relies on *Rules for the Design of Storm*
 27 *Drainage Facilities in the County of Maui* (§15-4) to govern the design of storm drainage facilities
 28 associated with development projects. These rules deal with stormwater management and
 29 conveyance systems that are quantity-based and do not address stormwater quality and pollution
 30 treatment.

31 The Department is currently undergoing final review and plans adoption of the proposed *Rules for*
 32 *the Design of Storm Water Treatment Best Management Practices* (§15-111) by the end of 2012.⁴⁶
 33 The rules will establish controls for the time and rate of stormwater runoff discharge to the
 34 maximum extent practicable, through implementation of BMPs and engineering control facilities
 35 that are designed for the reduction of pollution generation (County of Maui Department of Public
 36 Works 2012).

37 The new rules will apply to all new development and significant redevelopment projects with a
 38 disturbed area of greater than one acre. Factors such as future home construction, even if not

⁴⁶ As authorized by Maui County Code §16.26.3306 and §18.20.135 (Post-construction stormwater quality best management practices).

1 immediately constructed with the development of site improvements, may be taken into
 2 consideration by the Director of Public Works during review. These projects must meet the specific
 3 criteria for sizing of stormwater quality facilities, and must be prepared by a Hawai'i licensed
 4 Professional Engineer. The requirements are met through implementation of various water quality
 5 control management practices (e.g. extended detention wet and dry ponds, created wetlands,
 6 vegetated swales, bioretention cells). Additionally, projects with a disturbed area of less than one
 7 acre will be subject to approval of a site specific BMP plan proposed by the developer.

8 **5.5.2 Recommendations for Future Development**

9 SRGII fully supports and recommends adoption of the proposed §15-111 rules for all future
 10 residential, commercial, and industrial developments within Wahikuli and Honokōwai Watersheds.
 11 Incorporation of stormwater quality devices and LID technologies as specified in the rules will
 12 promote reduction of land-based pollution generation across the watersheds. Although the §15-111
 13 rules will apply to projects greater than one acre in size, it is recommended that the rules extend to
 14 all projects less than one acre in development area as well. Individual lot homeowners, regardless
 15 whether their property is included in a subdivision with a master drainage plan, should be
 16 encouraged to adopt LID practices on their parcels. The goal of this would be to reduce runoff
 17 generated on individual parcels, reduce use of potable water for irrigation of landscaped areas, and
 18 promote green practices throughout the County of Maui.

19 Homeowners are also encouraged to adopt practices that reduce their use and disposal of potable
 20 water. Techniques to facilitate this include low flush toilets and reuse of grey water (sink and
 21 shower water) instead of disposal down standard plumbing drains and flow to the WWRf for
 22 treatment and ultimate disposal down the injection wells.

23 In addition, it is recommended the following development practices be incorporated at the County
 24 level:

- 25 • To the maximum extent possible, include native plant xeriscaping into the design of LID
 26 practices, and include as a requirement for obtaining a building permit within Maui
 27 County.⁴⁷
- 28 • Require R-1 use for irrigation on resort and commercial business properties.
- 29 • Revise County of Maui building code to include section of green roof design.
- 30 • Provide incentives for incorporating green roof design into subdivisions.
- 31 • Encourage pervious surfaces for treatment and storage of stormwater runoff in lieu of
 32 paved roadways and standard detention ponds.
- 33 • Require new developments to evaluate and compare LID subdivision/commercial
 34 development vs. standard development layout: area of development impact, runoff quality
 35 at outlet point; area of impervious required.

36

⁴⁷ Xeriscaping refers to landscaping methods that reduce or eliminate the need for supplemental water from irrigation.

1 **6. Conclusions**

2 The WHWMP provides a comprehensive assessment of the existing conditions, with an emphasis on
3 identification of major pollutant sources, in the agricultural and urban areas of Wahikuli and
4 Honokōwai Watersheds. A significant level of effort was invested in compiling existing data and
5 information to determine, to the extent possible, the sources and relative contributions of historical
6 and current land based pollutants. While recommendations for priority projects and management
7 practices were developed to a conceptual level of design, the level of detail related to site-specific
8 recommendations was subject to limited field time and quantitative data and information necessary
9 to develop detailed designs for remedial practices was not collected. This WMP would have
10 benefitted from additional field work and design analysis to provide 'ready-to-implement'
11 solutions. Future WMPs in this area should focus more on site-specific analysis and design of
12 management practices (e.g. stormwater inventory and assessment) in order to serve as practical
13 guides for implementation. While the scientific basis for identifying and prioritizing problems is
14 important, action-oriented WMPs should acknowledge this science (including on-going work), and
15 focus on implementable solutions.

16 When choosing which pollution control strategies to implement, a comprehensive approach should
17 be employed. Each management practice will contribute to the overall success, but only in
18 combination will success be ensured (i.e. significant net reductions of pollutant runoff loads from
19 the watershed). Adaptive management should be used to evaluate the effectiveness of chosen
20 strategies in achieving watershed goals. Monitoring plays an essential role in providing the
21 information required for analysis.

22

1 This page intentionally left blank.

Appendices

Table of Contents

1

2

3 Appendix A. NPS Pollution Management Hierarchy A-1

4 A.1. What are Management Measures? A-1

5 A.2. What are Management Practices? A-2

6 A.3. Delineating Management Units A-3

7 A.4. Choosing Pollution Control Strategies A-5

8 A.5. Management Measures A-6

9 A.6. Management Practices A-14

10 A.7. Pollutant Load Reductions A-19

11 Appendix B. Priority Management Practices B-1

12 B.1. Baffle Box B-3

13 B.2. Bioretention Cell (Rain Garden) B-5

14 B.3. Road Drainage Improvements B-9

15 B.4. Road Realignment and Rebuilding B-17

16 B.5. Sediment Retention Basin B-19

17 B.6. Vegetated Filter Strip B-22

18 Appendix C. Secondary Management Practices C-1

19 C.1. Curb Inlet Basket (with Filter) C-2

20 C.2. Debris Removal C-4

21 C.3. Erosion Control Blanket / Turf Reinforcement Mat C-5

22 C.4. Facility Stormwater Assessment C-7

23 C.5. Good Housekeeping Practices C-10

24 C.6. Gutter Downspout Disconnection C-12

25 C.7. Irrigation Water Management Plan C-13

26 C.8. Natural/Native/Drought Resistant Vegetation C-15

27 C.9. Pesticide Management Plan C-17

28 C.10. Pond Sampling Plan C-18

29 C.11. Riprap C-19

30 C.12. Shoreline Erosion Control C-21

31 C.13. Storm Sewer Disconnection C-22

32 C.14. Vegetated Swale C-23

33 C.15. Other Secondary Management Practices C-25

34 Appendix D. Designing a Monitoring Program D-1

35 D.1. Data Management, Evaluation, and Reporting D-1

36 D.2. Types of Monitoring D-3

37 D.3. Effectiveness Monitoring Protocols D-9

38 Appendix E. Community Input E-1

39 E.1. List of Persons Consulted E-1

40 E.2. Public Input E-2

41 Appendix F. Information Cited F-1

42 F.1. References F-1

43 F.2. Personal Communication F-2

44 F.3. Geospatial Data F-3

1 This page intentionally left blank

1 **Appendix A. NPS Pollution Management Hierarchy**

2 Watershed management uses a hierarchy to address planning at different scales. By delineating
3 management measures and practices within the context of management units, it is possible to focus
4 pollution control activities on achieving specific goals.

5 **A.1. What are Management Measures?**

6 The Coastal Zone Management Act of 1972 created a program for U.S. states and territories to
7 voluntarily develop programs to manage and protect coastal resources. Although the protection of
8 water quality is a key component of these programs, it was not specifically cited in the original
9 statute. The Coastal Zone Act Reauthorization Amendments of 1990 (CZARA) specifically charged
10 State coastal programs and State NPS programs with addressing NPS pollution that affects coastal
11 water quality.

12 Management measures are defined in Section 6217 of CZARA as “economically achievable measures
13 for the control of the addition of pollutants from existing and new categories and classes of
14 nonpoint sources of pollution, which reflect the greatest degree of pollutant reduction achievable
15 through the application of the best available nonpoint pollution control practices, technologies,
16 processes, siting criteria, operating methods, or other alternatives.”¹ In general, management
17 measures are groups or categories of cost-effective management practices implemented to achieve
18 a comprehensive goal, such as reducing NPS pollutant loads.²

19 Management measures can be used to guide the implementation of a comprehensive NPS pollutant
20 and runoff management program. Some examples of WHWMP management measures that can help
21 control the delivery of pollutant loads to receiving waters are: erosion and sediment control
22 (reduce the load of sediment delivered to a water body); fertilizer management (apply fertilizers
23 based on plant needs to lessen amount lost in surface and groundwater); and irrigation
24 management (irrigate to minimize excess water that carries NPS pollutants). Management
25 measures and practices can be implemented for other related purposes, such as:

- 26 • Protecting water resources and downstream areas from increased pollution and flood risks.
- 27 • Conserving, protecting, and restoring stream habitat.
- 28 • Setting aside permanent terrestrial buffers for flow reduction and increased infiltration.

29 Management measures can be implemented using two different approaches. The most desirable
30 approach is to implement practices that prevent NPS pollutant generation. Known as a *preventive*
31 approach, this focuses on controlling or eliminating a specific pollutant at its source. Conversely, a
32 *treatment* approach is focused on treating a specific NPS pollutant along its entire pollution

¹ <http://www.epa.gov/owow/NPS/MMGI/Chapter1/ch1-1.html#Act>

² This report will follow the lead of EPA and use the term management practice instead of the more familiar term best management practice. The word “best” has been dropped for the purpose of this report, as it was in the *Guidance Specifying Management Measures for Sources of Nonpoint Pollution in Coastal Waters* (EPA 1993) and the *National Management Measures to Control Nonpoint Source Pollution from Hydromodification* (EPA 2007) because the adjective is too subjective. A “best” practice in one region or situation might be entirely inappropriate in another region or situation.

1 stream.³ The two approaches can be implemented individually or combined. From a watershed
 2 science perspective, a preventive approach is usually the best way to address NPS pollutants,
 3 because it reduces the need for greater resources to manage pollutants once released into the
 4 environment. However, preventive measures are not always technically feasible or cost-effective to
 5 implement, and it may take considerable time after they are installed for benefits to be realized.

6 The goal of a clean and attractive West Maui environment is best achieved when development or
 7 alteration is based on sound environmental and ecological practices, and resources preserved for
 8 the use of the public (Maui County Council 1996). Implementation of management measures varies
 9 according to the specific site. Incorporating one or more management measures at a specific site
 10 may be necessary to address multiple contributions of NPS pollution. Measures should be
 11 coordinated such that the overall system addresses all sources of NPS pollution in a cost-effective
 12 manner.

13 **A.2. What are Management Practices?**

14 A management practice is a specific action that can be implemented to achieve a management
 15 measure. Practices include individual treatments, strategies, and plans to lessen generation and
 16 transport of NPS pollutants. Management measures are typically implemented by applying one or
 17 more management practices according to the source, location, and climate (EPA 1993).

18 Similar to management measures, management practices can be grouped according to preventive
 19 and treatment approaches and combined as necessary. Preventive management practices
 20 (preventive practices) focus on reducing or eliminating the generation of a pollutant at its source
 21 (e.g. incorporation of conservation cover on the fallow seed corn fields). Conversely, treatment
 22 management practices (treatment practices) involve treating or controlling a particular NPS
 23 pollutant once it has left its source and entered the environment. Treatment practices are typically
 24 engineered designs that function either independently, or within an integrated group of practices.
 25 An example of a treatment practice is a retention basin, which collects sediment-laden water that
 26 has drained by gravity flow from upslope contributing drainage areas. When combined with one or
 27 more other treatment practices (such as a vegetated filter strip) along the sediment pollution
 28 stream, a higher percentage of efficiency in sediment removal can occur.

29 Treatment practices can be hard or soft: hard practices generally use structures made of concrete
 30 or synthetic materials (e.g. baffle box); while soft engineering practices are designed based on
 31 ecological practices, and use natural vegetation and materials. Some situations can call for both
 32 hard and soft engineering practices to maximize the best elements of each approach. For example, if
 33 a desired management measure is erosion and sediment control, then a vegetated swale (soft
 34 practice) could be constructed at the entrance to a baffle box (hard practice) upstream of a S4 and
 35 both could help achieve the management measure prior to stormwater entering the S4.

³ Pollution stream refers to the pathway a pollutant follows across a watershed from its source to its sink. Within the Kā'anapali Region, this pathway is generally dictated by the course taken by rainfall-generated runoff, as the majority of NPS pollutants migrate downstream intermixed within runoff water.

A.3. Delineating Management Units

Volume 1: Watershed Characterization, used three State Land Use Districts (Conservation, Agricultural, and Urban) to characterize the watersheds and describe the types of pollutants generated within each District (Table A.1). In *Volume 2* (this document), the term “District” is replaced with “Management Unit” when describing areas of pollution generation, but the terms, “Conservation,” “Agricultural,” and “Urban” are retained. Delineating the watersheds into these management units creates three discrete geographic areas, each with its own pollutant sources, pollutant types, and land uses.⁴ This aids in the analysis of the sources and pathways of NPS pollutants, and allows specific management measures and practices to be recommended for each unit.

Table A.1. Management Units in Wahikuli and Honokōwai Watersheds

Management Unit	Honokōwai (acres / %)	Wahikuli (acres / %)	Total (acres / %)	Primary Land Use	Primary Land Cover
Conservation	2,302 (61% Conservation) (41% Watershed)	1,464 (39% Conservation) (23% Watershed)	3,766 (31% Total)	Preservation	Forest
Agricultural	3,088 (48% Agricultural) (55% Watershed)	3,393 (52% Agricultural) (53% Watershed)	6,481 (54% Total)	Cropland and Vehicular Egress Routes	Vegetated fallow fields; bare and vegetated active fields; dirt access roads, vegetative and bare field types
Urban	241 (13% Urban) (4% Watershed)	1,563 (87% Urban) (24% Watershed)	1,804 (15% Total)	Residential; Commercial; Resorts; Golf Courses; Light Industry	Impervious (buildings, pavement); landscaped and lawn areas
Total	5,631 (47% Total)	6,420 (53% Total)	12,051		

Conservation Management Unit

The Conservation Management Unit includes lands within the bounds of the Conservation District. It is located in the middle to upper elevations of the two watersheds, with the exception of a small coastal parcel, Wahikuli Wayside Beach Park. Most of the Conservation Unit lands are contained within one of three forested reserves. In both watersheds, the Conservation Unit boundary generally runs parallel to the watershed contours and varies between elevation 1,100 ft (335 m) and 2,100 ft (640 m) mean sea level (msl).

The Conservation Unit lands are located at elevations that receive up to 380 inches (9,562 mm) of rain per year. This area functions as a reservoir and captures a portion of the high rainfall volume, slowly releasing water that soaks into its surfaces to sustain stream flows and recharge the underground aquifers. The lands within the steep mountainous terrain host native forest plant communities that are degraded from illegal dirt bike use, disturbance of ground cover by feral ungulates, and alien plant species, which compromise the ecohydrologic services the forest provides.

⁴ See *Volume 1: Watershed Characterization*, Section 3 for additional information on the various landowners, land uses, and geographic characteristics of the three Districts.

1 The WMMWP manages lands in the upland Conservation Unit for the protection of the West Maui
 2 Watershed, and to prevent further degradation. Management priorities include: feral animal
 3 control; weed control; human activities management; public education and awareness; water and
 4 watershed monitoring; and management coordination improvements.⁵ Information on specific
 5 activities occurring within the Conservation Management Unit aimed at reducing NPS pollution is
 6 presented in the WMMWP WMP, and is not covered in the WHWMP (WMMWP 1999).⁶

7 **Agricultural Management Unit**

8 The Agricultural Management Unit includes lands within the bounds of the Agricultural District. For
 9 nearly a century sugarcane and pineapple fields covered almost 40 percent of the land area within
 10 the watersheds. Today, sugarcane and pineapple fields remain fallow, though there are some fields
 11 with pineapple crops. The majority have vegetative ground cover, primarily a mixture of non-native
 12 grasses and shrubs. Due to the arid conditions in the lower elevations of the watersheds, these
 13 plants are often dry and are a potential fuel source for wildland fires.

14 Current agricultural activities include the cultivation of coffee and until very recently, seed corn,
 15 with both crops grown in areas once used to grow sugarcane.⁷ Field cover includes both active crop
 16 fields and unmanaged fallow fields. Tracts of agricultural lands in the Wahikuli Watershed are
 17 currently being developed as small scale single owner coffee farms. Of total coffee fields,
 18 approximately 50% are presently under active cultivation, while 50% lay fallow. Cropping practices
 19 vary among the active farm fields, as does the ground cover growing in rows between the cultivated
 20 crops.

21 Pasture lands are located upslope and adjacent to fallow sugar cane fields in Wahikuli Watershed.
 22 They are overgrown with shrubs, small trees, and non-native grasses. The Agricultural Unit extends
 23 from the WMMWP management boundary downslope to the Honoapi'ilani Highway, and the lower
 24 limits vary in elevation from 50 ft (15 m) to 300 ft (91 m) msl.

25 **Urban Management Unit**

26 The Urban Management Unit includes lands within the bounds of the Urban District. The Urban Unit
 27 extends from the valley floor along the coastline (msl) to both the *mauka* (inland) and *makai*
 28 (ocean) sides of the highway. The upper limits of the Urban Unit vary between elevation 50 ft (15
 29 m) and 350 ft (107 m) msl in terms of actual development. The Urban Unit of the two watersheds
 30 have a total of 382 acres (154 ha) of impervious surfaces (109 acres (44 ha) in Honokōwai
 31 Watershed; 273 acres (110 ha) in Wahikuli Watershed) covering three percent of the total
 32 watershed area. The percentage in Wahikuli Watershed is skewed low since much of the urban
 33 lands are *mauka* of Honoapi'ilani Highway in an area that contains large lots with only a portion
 34 covered by impervious surfaces. The resorts, hotels, and condominiums fronting the ocean and
 35 located between the highway and the ocean contain nearly 40 percent impervious surfaces when

⁵ <http://www.westmauiwatershed.org>

⁶ The WMMWP WMP is currently under revision, with a draft due out in July 2012.

⁷ Seed corn growers used a rotational grow cycle distributed over approximately 600 acres. At any one time, 300 acres were planted with corn and 300 acres were bare ground or covered with residual crops or grass. Bare fields adjacent to active corn fields were used to minimize cross-pollination potential of the corn crop. At time this report was being prepared, most of the seed corn fields are fallow.

1 looked at as a subset of the Wahikuli Urban Unit. Nearly all impervious surfaces within Wahikuli
 2 and Honokōwai Watersheds are manmade features. The Maui County owned and operated Lahaina
 3 WWRF treats raw sewage collected from the project area's Urban Unit and areas north to Kapalua
 4 and south to Lahaina.

5 Managed landscaped surfaces are present within the Urban Unit at golf courses, resorts, and
 6 residential and commercial properties. Non-native and ornamental plants are the primary
 7 vegetation except along beach front resort properties north of the Black Rock area, where native
 8 plants dominate the vegetation communities, most likely due to development permit requirements.
 9 Landscaped areas are considered permeable surfaces that allow a percentage of rainfall and
 10 irrigation water into the ground.

11 **A.4. Choosing Pollution Control Strategies**

12 Pollution control strategies for the project area were selected based on established guidelines for
 13 the adoption of management measures and management practices. In addition, a large volume of
 14 research has been developed by researchers in the West Maui region with respect to various
 15 pollutants generated, their sources, and the effects they have on the coastal environment.

16 Several published documents and other data sources were consulted during the selection of
 17 management measures:

- 18 • *Guidance Specifying Management Measures for Sources of Nonpoint Pollution in Coastal*
 19 *Waters* (EPA 1993);
- 20 • *Hawai'i's Management Measures for the Coastal Nonpoint Pollution Control Program*
 21 *(Stewart 2010a);*
- 22 • *Responsible Agencies and Authorities - A Supplemental for Hawai'i Management Measures*
 23 *(Stewart 2010b)*, a comprehensive document that covers the various agencies that can aid
 24 in the implementation of management measures within watersheds;
- 25 • *The West Maui Community Plan* (Maui County Council 1996), which details the goals for
 26 preferred future conditions of West Maui, in order to enhance the region's overall living
 27 environment;
- 28 • Historic sources of NPS pollution within the management units, obtained through
 29 interviews with stakeholders;
- 30 • Observations conducted infield in order to identify current NPS pollutant hotspots
 31 presenting a hazard to the health of the ecosystem;
- 32 • Analysis of high intensity aerial photography in order to identify NPS pollutant hotspots
 33 covering significant surface area within the watersheds.

34 Selection of management practices was based on several published documents as well as common
 35 engineering practices used for pollution remediation. Documents include:

- 36 • *Hawai'i's Management Measures for the Coastal Nonpoint Pollution Control Program*
 37 *(Stewart 2010a)* (Agricultural and Urban Management Units)

- 1 • NRCS Hawai'i Field Office Technical Guide⁸ conservation practice standards for use in the
- 2 Pacific Islands Area (Agricultural Management Unit)
- 3 • *Plant Nutrient Management in Hawaii's Soils: Approaches for Tropical and Subtropical*
- 4 *Agriculture* (Silva and Uchida 2000) which details practices for use to assure proper
- 5 management of nutrients (Agricultural Management Unit)
- 6 • *National Management Measures to Control Nonpoint Source Pollution from Urban Areas* (EPA
- 7 2005) (Urban Management Unit)
- 8 • *The West Maui Community Plan* (Maui County Council 1996), which details the objectives,
- 9 policies, and implementing actions regarding land use and activities, and their relation
- 10 toward reaching the goals that have been set within the plan (Agricultural and Urban
- 11 Management Units)

12 **A.5. Management Measures**

13 Management measures are economically achievable measures for the control of the addition of NPS
 14 pollutants (Appendix A.1). There are nine management measures that apply to the Kā'anapali
 15 Region that fall into two categories in regard to implementation sequence: *priority* and *secondary*.
 16 Priority measures are those considered most critical, and deemed to have the most significant
 17 potential for reducing overall land-based pollution impact to the West Maui marine environment.
 18 They should be addressed first, with the appropriate practices. Secondary measures are those
 19 strongly encouraged for addressing subsequent to the implementation of priority measures. Several
 20 sites within the project area are identified for priority measures and will require detailed remedial
 21 designs to be developed in order to identify practice(s) and specifications.

22 Table A.2 summarizes the priority and secondary measures, with the management unit(s) to which
 23 they apply and the approach (preventive, treatment, or both) used to address them. The majority of
 24 management measures are specified for both of the management units; this overlap is the result of
 25 shared presence of pollutants within the units.

26 There are numerous management measures that could be used to achieve the objective of
 27 minimizing pollutant input to the coral reef ecosystem of West Maui, and measures not presented in
 28 the WHWMP should not necessarily be excluded from consideration. Selection of management
 29 measures for inclusion in the WHWMP favored those that would reduce levels of several types of
 30 NPS pollutants and/or attenuate generation of storm water runoff.

31

⁸ <http://efotg.sc.egov.usda.gov/treemenuFS.aspx>

1 **Table A.2. Management Measures, Management Units, and Implementation Approach**

Management Measure	Management Unit		Implementation Approach	
	Agricultural	Urban	Preventive	Treatment
Priority				
Erosion and Sediment Control	✓	✓	✓	✓
Nutrient	✓	✓	✓	✓
Effluent Disposal		✓	✓	
Secondary				
Pesticide	✓	✓	✓	
Bacteria	✓	✓	✓	
Irrigation Water	✓	✓	✓	
Debris/Litter	✓		✓	✓
Hydrocarbon		✓		✓
Runoff Control	✓	✓		✓

2 **Priority Management Measures**

3 Priority management measures that apply to the Agricultural and Urban Management Units are
 4 considered the most critical for implementation with respect to protecting the West Maui marine
 5 environment. They include the Erosion and Sediment Control; Nutrient; and Effluent Disposal
 6 Management Measures.

7 **Erosion and Sediment Control Management Measure**

8 The Erosion and Sediment Control Management Measure applies to all lands within the Agricultural
 9 and Urban Units that are actively eroding or have the potential to actively undergo erosion at rates
 10 greater than background. It applies to lands that are not permanently stabilized with vegetative
 11 ground cover, impervious cover, or other erosion-resistant surfaces. The goal of the measure is to
 12 reduce erosion rates to control the generation and transport of sediment to the maximum extent
 13 practical. This measure is given priority status since one of the primary pollutants of focus in this
 14 WHWMP is sediment. It is also important since a large portion of the Agricultural Unit consists of
 15 active fields and exposed dirt access roads, and the potential for erosion from these sources is very
 16 high. Fallow fields also have the potential for accelerated erosion due to natural wind and water
 17 erosion processes, although field inspections indicated that they are not a significant threat to
 18 watershed health at this time.

19 Application of the measure will reduce the mass loading of sediment reaching streams and the
 20 ocean, resulting in water quality improvement. The measure addresses:

- 21 • Surface erosion (sheet, rill and gully);
- 22 • Wind erosion;
- 23 • Streambank erosion;
- 24 • Soil mass movements;
- 25 • Erosion of roadways;
- 26 • Construction site erosion.

1 Within the Agricultural Unit, preventive approaches for this measure should be implemented on
 2 active agricultural fields to prevent erosion and transport of sediment from the fields.⁹ Preventive
 3 approaches should also be implemented within stream channels in specific sections where erosion
 4 is currently taking place. Agricultural Unit treatment approaches include directing runoff from
 5 fields and access roads through placement of practices within the runoff pollution stream to
 6 remove generated sediment. Within active fields, the measure may increase the potential for water
 7 movement and soluble pollutant movement through the soil profile into the groundwater, because
 8 a higher volume of water from rainfall or irrigation sources will be contained within the fields. To
 9 address this issue, groundwater protection will be enhanced through implementing management
 10 measures to reduce and control application of nutrients and pesticides.

11 Within the Urban Unit, the majority of developed land surfaces are covered by impervious or
 12 landscaped surfaces. However, there are areas of exposed soils that erode including developed
 13 surfaces that lack stabilization through paved, grassed, building, or other permanent surface, as
 14 well as eroding natural stream channel sections. This measure is accomplished through preventive
 15 approaches on these exposed soil areas. This measure is also accomplished through a combination
 16 of preventive and treatment approaches for land development projects. Preventive approaches are
 17 generally utilized for the construction phase of development activities, while preventive and
 18 treatment approaches are typically used post-construction phase.

19 ***Application of Measure to Various Land Uses***

20 New Developments

21 For new developments, the measure: (1) decreases the potential for erosion due to increases in
 22 volume and rates of runoff due to development within the watersheds; and (2) removes solids and
 23 associated pollutants from construction and post-construction site activities that are suspended in
 24 runoff. Through design or performance of future developments, one of the following applies: the
 25 benchmark for reduction of TSS loadings is 80% on an annual load basis, upon completion of
 26 construction and final site stabilization. Alternatively, the reduction of TSS post-development
 27 loadings such that they are below pre-development levels on an annual basis should be employed.

28 Golf Courses

29 Grading and Site Plans for golf courses should adhere to the following:

- 30 - Design and construct both management and physical practices to promote settling of solids
 31 and associated pollutants from both rainfall and wind events.
- 32 - Retain sediment onsite and prevent erosion as much as possible both during and post-
 33 construction.
- 34 - Protect sensitive ecosystems.
- 35 - Avoid construction in erosion-prone areas.
- 36 - Establish buffers to protect waterbodies and natural channels.

⁹ As discussed in Section 6.4.1.3 of Volume 1, subsequent to preparation of this WHWMP it was learned that Monsanto will no longer be operating seed corn fields within the West Maui region. It is unknown what farming activities or crop types will be grown on the now-abandoned seed corn fields. Regardless of whether another grower takes over seed corn cultivation, this measure will apply, as sediment is an ongoing issue with bare or partially vegetated fields. If the fields are left dormant with minimal vegetative cover, this could potentially be a more dire situation in regard to sediment generation than when the fields were operational, as there will be no crops actively protecting a portion of the plots.

- 1 - Follow U.S. Golfing Association construction guidelines for greens.

2 Eroding Streambanks and Shorelines

3 When stabilizing eroding streambanks and shorelines, the measure applies as follows.

- 4 - Stabilize streambanks and shorelines in areas where erosion is a serious NPS pollution
5 problem. Vegetative methods are preferred, though structural methods may be necessary in
6 areas where vegetative methods do not work and where there will be no interference with
7 natural processes or potential for harm to ecologically sensitive areas.
- 8 - Protect both streambank and shoreline features that currently serve to reduce NPS
9 pollution.
- 10 - Protect both streambanks and shorelines from use involved with either shorelands or
11 adjacent surface waters.
- 12 - Remove artificial fill in areas where it is eroding into adjacent streams or coastal waters.

13 Planning/Siting/Developing Roads and Highways

14 To protect susceptible areas from erosion and sediment loss, and to protect areas providing water
15 quality benefits:

- 16 - Limit the extent of land disturbance, including clearing, grading, and cut and fill in an effort
17 to reduce the effects of erosion and sediment loss.
- 18 - Limit disturbance to natural drainage features and vegetation affected by these activities.

19 **Nutrient Management Measure**

20 The Nutrient Management Measure applies to activities associated with nutrient application, which
21 primarily take the form of fertilizer application for plant growth, on lands within the Agricultural
22 and Urban Management Units. Within the Agricultural Unit, the goal of the measure is to minimize
23 the edge-of-field delivery of nutrients and minimize the leaching of nutrients from the root zone on
24 agricultural fields. This is accomplished by:

- 25 • Developing a nutrient budget for crops;
- 26 • Applying nutrients at the proper time;
- 27 • Applying only the types and amounts of nutrients necessary to produce the crop;
- 28 • Considering site environmental hazards.

29 At present, the measure applies only to the active coffee fields within the Agricultural Unit.¹⁰ The
30 measure does not apply to fallow fields or any other land uses that do not actively incorporate
31 nutrient application within the unit. Although legacy use of nutrients occurred on sugarcane and
32 pineapple fields within the watersheds, and it is assumed that legacy nutrient use contributes to
33 groundwater NPS pollution, the effects have not been quantified. The measure will usually result in
34 reduced nutrients migrating offsite within stormwater runoff. Nutrients that migrate offsite

¹⁰ As discussed in Section 6.4.1.3 of Volume 1, subsequent to preparation of this WHWMP it was learned that Monsanto will no longer be operating seed corn fields within the West Maui region. It is unknown what farming activities or crop types will be grown on the now-abandoned seed corn fields. If another grower takes over seed corn cultivation within the project area, the Nutrient Management Measure will apply. If this does not happen, the measure will not apply as the fields will lie fallow.

1 attached to soil particles will be addressed through the erosion and sediment control measure. The
 2 measure is accomplished by implementing preventive approaches on active fields.

3 Within the Urban Unit, the measure applies to all landscaped and lawn surfaces that incorporate
 4 active nutrient application to promote and maintain vegetative growth. This includes resorts,
 5 hotels, commercial businesses, and golf courses. The goal of the measure is to minimize delivery of
 6 nutrients from landscaped and lawn areas, as well as leaching of nutrients from the root zone of
 7 these areas. The measure is accomplished by implementing preventive approaches on these
 8 surfaces.

9 The basis for the measure is the creation and implementation of a fertilizer management plan. In
 10 the Agricultural District, the purpose of the fertilizer management plan is to ensure nutrients are
 11 applied efficiently for realistic crop yields, make improvements to nutrient application timing, and
 12 increase the efficiency of nutrient use through agronomic crop production technology. The
 13 incorporation of a soil and/or plant tissue testing schedule is also an integral part of the measure. In
 14 the Urban District, the purpose of the fertilizer management plan is to ensure nutrients are applied
 15 efficiently for sufficient vegetative growth and to ensure over-fertilization of landscaping/lawns is
 16 prevented to the greatest extent possible.

17 **Effluent Disposal Management Measure**

18 The Effluent Disposal Management Measure applies to the Urban Unit, specifically to the nutrients
 19 and other pollutants contained in effluent disposed into the Lahaina WWRF injection wells. The
 20 transport of nutrients injected into the wells through the groundwater and into surface waters
 21 along the coastline has been well documented, as the subject of several published research papers.
 22 The WWRF operations and research findings are described in Section 6.6 of Volume 1. Seeps have
 23 been discovered along the coastline containing constituents that are characteristic of the injected
 24 effluent. The goal of the measure is to reduce the loading of nutrients and other pollutants injected
 25 into the groundwater through effluent disposal, and application of this measure will accomplish
 26 this goal. The measure is accomplished through treatment approaches.

27 **Secondary Management Measures**

28 There are five secondary management measures that apply to the Agricultural and Urban
 29 Management Units: Pesticide; Bacteria; Irrigation Water; Debris/Litter; Hydrocarbon; and Runoff
 30 Control Management Measures. These measures are recommended for implementation after all
 31 priority measures have been addressed.

32 **Pesticide Management Measure**

33 The Pesticide Management Measure applies to activities associated with the application of
 34 pesticides in both the Agricultural and Urban Management Units. The goal of the measure is to
 35 reduce contamination of surface water and groundwater from pesticides through effective and safe
 36 use. The most effective approaches to reducing pesticide pollution are releasing fewer and/or less
 37 toxic pesticides, and using practices that minimize the movement to surface and groundwater.

1 The Pesticide Management Measure applies to the active fields within the Agricultural Unit, namely
 2 active coffee crops, because pesticide application occurs only on these fields.¹¹ Within the Urban
 3 Unit, the measure applies to all landscaped and lawn surfaces that incorporate active pesticide
 4 application. The measure is accomplished by implementing both preventive and treatment
 5 approaches. There are four core components of the measure:

- 6 • Minimizing chemical uses for pest control by implementing an integrated pest management
 7 strategy;
- 8 • Practicing efficient pesticide management by keeping equipment calibrated, choosing
 9 appropriate pesticides utilized for the immediate site, utilizing alternative pest control
 10 methods, and reducing the migration of pest control agents from the area as much as
 11 possible;
- 12 • Implementation of anti-backflow devices on tank filling hoses;
- 13 • Increasing organic matter content or adjusting pH levels within the soil to increase
 14 degradation or retention of pesticides.

15 **Bacteria Management Measure**

16 The Bacteria Management Measure applies to all lands within the Agricultural and Urban
 17 Management Units that actively generate bacteria. Within the Agricultural Unit, this includes the
 18 upper fields close to the Conservation Management Unit where feral ungulates and wildlife waste
 19 matter accumulates. Within the Urban Management Unit, this includes wherever wildlife or
 20 domestic animal waste is present; as well as residential properties on private sewer systems. The
 21 goal of the measure is to reduce bacterial presence to the greatest extent practical. Application of
 22 the measure will reduce the presence of bacteria within the watersheds, reducing incidence of
 23 infections from pathogenic presence. The measure is accomplished by implementing preventative
 24 approaches.

25 **Irrigation Water Management Measure**

26 The Irrigation Water Management Measure applies to all irrigated lands within the watersheds in
 27 both the Agricultural and Urban Management Units. The goal of the measure is to reduce surface
 28 water NPS pollution due to irrigation activities. The movement of pollutants from land into
 29 groundwater and surface water is directly related to management of the irrigation system, as
 30 typical pollutants applied through an irrigation system can include:

- 31 • Sediment and particulate organic solids;
- 32 • Particulate-bound nutrients, chemicals (e.g. pesticides), and metals;
- 33 • Soluble nutrients, chemicals (e.g. pesticides), metals, salts;
- 34 • Bacteria, viruses, and other micro-organisms.

35 Application of this management measure will reduce the waste of irrigation water, improve water
 36 use efficiency, and reduce total pollutant discharge from irrigation systems. The measure is
 37 accomplished through implementation of preventive approaches.

¹¹ Similar to as stated above, the dormancy of the seed corn fields at the immediate time renders the Pesticide Management Measure applicable to the coffee fields only; although this may change if a new grower restarts cultivation of the seed corn fields.

1 Within the Agricultural Management Unit, the measure applies to the active coffee crop fields.¹²
 2 There are two main aspects of this measure. The first is to develop irrigation scheduling so that the
 3 timing and amount of water applied equals the plant's uptake in order to reduce potential for
 4 seepage. The second aspect applies when chemigation is utilized. Chemigation is the process of
 5 applying chemicals (e.g. pesticides) to fields through an irrigation system. In this case, a
 6 combination of incorporating well backflow preventers, minimizing discharge of chemigated
 7 waters along the field edges, and control of percolation depth will reduce NPS pollution generation.
 8 On fields where irrigation management currently conforms to the measure, additional devices for
 9 soil-water depletion measurements, irrigation water volume computations, or additional labor
 10 resources for managing the system may not be necessary.

11 Within the Urban Management Unit, the measure applies to all properties that utilize irrigation
 12 systems for watering and maintaining vegetative growth on landscaped and lawn areas.

13 **Debris/Litter Management Measure**

14 The Debris/Litter Management Measure applies to all lands within the Agricultural Management
 15 Unit that actively exhibit accumulated debris. This includes illicit dumping sites identified during
 16 infield observations, as well as other locally known areas of accumulation. The goal of the measure
 17 is to reduce the presence of debris and litter in illicit dumping areas and prevent the introduction of
 18 debris and litter.

19 Application of the measure will reduce the mass loading of debris and litter reaching streams and
 20 the ocean, resulting in water quality improvement. This measure relies on implementation of
 21 prevention and treatment approaches at all substantial and repeat dumping sites. Prevention
 22 strategies include informing the public of the illicit nature of dumping. Treatment approaches
 23 include removal of debris from within the runoff pollution stream to the greatest extent practical.

24 **Hydrocarbon Management Measure**

25 The Hydrocarbon Management Measure applies to all lands within the Urban Management Unit
 26 associated with generation and transport of hydrocarbons from presence of motor vehicles.¹³ This
 27 measure primarily applies to lands that incorporate impervious cover, and in particular directly
 28 connected impervious areas (DCIA), because rainfall runoff readily intermixes with hydrocarbons
 29 accumulated on smooth surfaces and is quickly transported offsite.¹⁴ The goal of the Hydrocarbon
 30 Management Measure is to capture hydrocarbons present in the urban environment to the greatest
 31 extent practical. Application of the measure will reduce the loading of hydrocarbons contained in
 32 rainfall runoff and typically sourced from motor vehicle presence. This can result in decreased
 33 loadings reaching streams and the ocean, and therefore improve water quality. The measure is
 34 accomplished through implementation of treatment approaches.

¹² Similar to as stated above, the dormancy of the seed corn fields at the immediate time renders the Irrigation Water Management Measure applicable to the coffee fields only; although this may change if a new grower restarts cultivation of the seed corn fields.

¹³ It is assumed that hydrocarbon presence and transport in the Agricultural Unit is minimal due to sparse vehicle usage.

¹⁴ DCIA are impermeable areas that drain directly to an improved drainage component such as a street, gutter, ditch, or pipe that is part of the S4. An example is a roof that drains into a gutter draining into a downspout, which discharges onto a driveway discharging water onto a street, which runs down a curb into an inlet into a pipe and into Honokowai Stream. The smooth surfaces of these man-made features increase the velocity that water travels at from its point of concentration to its outlet.

1 The majority of Urban Unit developed land is currently covered by impervious or landscaped
 2 surfaces. Many existing sites do not incorporate a hydrocarbon management measure. However, in
 3 some instances, runoff control measures result in hydrocarbon capture as well. Where this is not
 4 the case, the measure can be implemented through treatment approaches and may overlap to an
 5 extent with the implementation of the runoff control measure. The implementation process
 6 involves directing runoff from existing impervious areas with high vehicle egress through practices
 7 placed in close proximity to the location of generated runoff. This will promote onsite treatment
 8 and retention of hydrocarbons contained within runoff. The measure can also be incorporated into
 9 the design process for future developments or redevelopments occurring within the Urban Unit.

10 When future developments (including master planned communities) that are currently planned for
 11 the Agricultural Management Unit are completed, this measure will apply to those sites as well. At
 12 that time, treatment practices should be implemented in a similar fashion to those of the Urban
 13 Unit. The development of these properties will introduce impervious surfaces and an influx of
 14 vehicular traffic for egress, and result in hydrocarbon accumulation.

15 **Runoff Control Management Measure**

16 The Runoff Control Management Measure applies to all land development activity that results in
 17 increased generation and volume of rainfall runoff from a given site, in respect to pre-developed
 18 conditions. This includes lands within both the Agricultural and Urban Units, and applies to lands
 19 that incorporate impervious cover, buildings, and semi-pervious surfaces that effectively reduce the
 20 soil infiltration rate upon completion of development. The goal of the Runoff Control Management
 21 Measure is to mitigate increased flow rates and volumes resulting from development of a given site.
 22 Post-development conditions should approximate as closely as possible pre-development
 23 conditions in respect to volume of runoff and runoff rates. Application of the measure will reduce
 24 the volume, timing, and peak discharge rate of surface rainfall runoff leaving the boundary of a site.
 25 This can result in decreased loadings of NPS pollutants (e.g. sediment and nutrients) reaching
 26 streams and the ocean, and therefore water quality improvement. The measure is accomplished
 27 through implementation of treatment approaches.

28 Within the Agricultural Unit, treatment strategies should be implemented within agricultural
 29 subdivision lots and the future master planned communities planned for the region. The change in
 30 land cover associated with these developments will bring a high percentage of impervious coverage
 31 to lands currently characterized as pervious or semi-pervious. Agricultural Unit treatment
 32 approaches include directing runoff from impervious and landscaped areas through practices
 33 placed in close proximity to the location of generated runoff. The measure will promote water and
 34 soluble pollutant movement through the soil profile into the groundwater, because a higher volume
 35 of water from rainfall will be contained onsite. This process will approximate pre-development
 36 infiltration patterns to an extent. This treatment approach is in contrast to the conventional method
 37 of collecting runoff at a central location within a development with little opportunity for
 38 groundwater recharge across the site landscape.

39 Within the Urban Unit, the majority of developed land is currently covered by impervious or
 40 landscaped surfaces. Many existing sites do not incorporate control of runoff prior to discharge.
 41 However, there are areas where the measure can be implemented through treatment approaches.
 42 This process involves directing runoff from existing impervious and landscaped areas through

1 practices placed in close proximity to the location of generated runoff. This will approximate pre-
 2 development infiltration patterns to an extent, without necessitating a central collection location
 3 for stormwater. The measure can also be incorporated into the design process for future
 4 developments or redevelopments occurring within the Urban Unit.

5 **A.6. Management Practices**

6 A set of management practices have been identified for implementation within the Agricultural and
 7 Urban Management Units based on the targeted pollutants and hotspots (Table A.3). Management
 8 practices were chosen based on their expected performance to reduce sediment, nutrient, and other
 9 types of NPS pollutants that currently impact the coral reef environment.

10 Practices selected were based on those most appropriate and effective to address the NPS pollutant
 11 site, NPS pollutant type, and/or the land use and activity that generates the NPS pollutant.
 12 Management practices are divided into two major categories: *priority* and *secondary* (Appendix B
 13 and C). Priority practices are those deemed most critical for implementation and secondary refers
 14 to those recommended for implementation after priority needs have been satisfied or as
 15 opportunities arise. Using best professional judgment, management practices were also assessed
 16 and prioritized based on a number of criterion, including pollutant load reduction potential, land
 17 acreage affected, landowner “buy-in,” cost, ease of implementation, and potential for educational
 18 outreach and exposure to the community. This process resulted in proposed practices being placed
 19 in priority order.

20 Priority practices are those preventive and treatment practices that are targeted for
 21 implementation as soon as the necessary resources have been secured. Upon full implementation,
 22 these practices are expected to reduce loads of land-based pollutants and have positive benefit on
 23 the overall health of the coral reef system, by either preventing the generation of NPS pollutants at
 24 the source, or treating them prior to reaching the ocean. Some of these priority practices will
 25 reduce land-based pollutant loads and have positive benefit whether or not they are implemented
 26 at all locations identified. Secondary practices are targeted for sources and sites of NPS pollutants
 27 that generate pollutant at rates less than the priority sites. As resources and opportunities become
 28 available to implement secondary practices, they will increase the cumulative NPS load reduction
 29 off the two watersheds.

30 Management practices can also be classified as either preventive or treatment. Preventive practices
 31 can be considered a proactive approach toward NPS pollution management in that they anticipate
 32 and prevent issues before they develop. There may be a lag time between when preventive controls
 33 are implemented and significant reduction of NPS pollutants are achieved. Treatment practices are
 34 focused on the need to treat NPS pollution after a specific pollutant source or sources have begun to
 35 cause detriment to the environment. They are expected to provide immediate NPS load reductions.
 36 In the long term, the best solution to reducing the amount of land-based pollutants reaching the
 37 ocean is to prevent generation and/or reduce generation to background levels. However in some
 38 instances this is not immediately feasible due to high costs, land management constraints, and long
 39 range time commitments. The use of preventative and treatment practices depends on the type of
 40 NPS pollutant, land use and activity, and flow paths transporting the NPS pollutant. At many sites a
 41 combination of preventative and treatment practices will be employed.

Management Practices and Their Applicability to Management Measures

Table A.3 lists the management practices recommended for the Wahikuli and Honokōwai Watersheds, and the management measures to which each applies. Several of the practices apply to more than one management measure. For example, disconnection of the storm sewer system in strategic areas of the Urban Unit and instead allowing vegetative treatment of stormwater to take place accomplishes goals applicable to nearly all of the management measures.

Table A.3. Management Practices and the Management Measures to which they Apply

Management Practice (bold = priority)	Management Measures								
	Erosion and Sediment Control	Nutrient	Effluent Disposal	Pesticide	Bacteria	Irrigation Water	Debris/Litter	Hydrocarbon	Runoff Control
Priority									
Baffle Box	✓	✓					✓	✓	✓
Bioretention Cell (Rain garden)	✓	✓		✓	✓		✓	✓	✓
Conservation Cover	✓	✓		✓					✓
Dam Debris Port Retrofit	✓	✓		✓	✓		✓		✓
Fertilizer Management Plan		✓							
Post-Fire Rehabilitation Plan	✓	✓		✓	✓		✓		✓
Road Drainage Improvements	✓								✓
Road Realignment and Rebuilding	✓	✓							✓
Sediment Basin	✓	✓		✓	✓		✓	✓	✓
Vegetated Filter Strip	✓	✓			✓				✓
WWRF Alternate Disposal	✓	✓	✓		✓	✓			
Secondary									
Curb Inlet Basket (with Filter)	✓	✓					✓	✓	
Debris Removal		✓					✓		
Erosion Control Blanket / Turf Reinforcement Mat	✓	✓							✓
Facility Stormwater Assessment		✓	✓	✓	✓		✓	✓	✓
Good Housekeeping Practices	✓	✓		✓	✓	✓	✓		
Gutter Downspout Disconnection	✓								✓
Illicit Dumping Signage							✓		
Irrigation Water Management Plan	✓	✓		✓		✓			
Natural/Native/Drought Resistant Vegetation	✓	✓							✓
Pesticide Management Plan				✓					
Pond Sampling Plan		✓		✓	✓				
Riprap	✓								✓
Shoreline Erosion Control	✓	✓							
Storm Sewer Disconnection	✓	✓		✓	✓	✓	✓	✓	✓
Vegetated Swale	✓	✓		✓				✓	
Vehicle Washwater Containment		✓						✓	✓

Management Practices and Pollutant Types

Table A.4 illustrates the relationship between management practices and pollutant types generated within the project area. Each of the practices applies to at least one of the six major pollutant types, while several of the practices apply to multiple types. Association with more than one pollutant does not necessarily imply that the practice is more effective at removal of each of the types.

- 1 Practices that are concentrated on one main pollutant, such as creating and adhering to an effective
 2 fertilizer management plan to reduce nutrient-related pollutants, can also be highly successful.

3 **Table A.4. Management Practices and Their Applicability to Pollutant Type**

Management Practice (bold = priority)	Pollutant Type					
	Sediment	Nutrients	Organics	Bacteria	Debris / Litter	Hydrocarbons
Priority						
Baffle Box	✓	✓			✓	✓
Bioretention Cell		✓	✓			✓
Burn Area Emergency Rehabilitation Plan	✓	✓				
Conservation Cover	✓					
Dam Debris Port Retrofit	✓	✓	✓	✓	✓	
Fertilizer Management Plan		✓				
Road Drainage Improvements	✓					
Road Realignment and Rebuilding	✓					
Sediment Retention Basin	✓					
Vegetated Filter Strip	✓					
WWRF Alternate Disposal: Increase Production and Reuse of R-1 Water	✓	✓		✓		
Secondary						
Curb Inlet Basket (with Filter)	✓				✓	
Debris Removal					✓	
Erosion Control Blanket / Turf Reinforcement Mat	✓					
Facility Stormwater Assessment	✓	✓	✓		✓	✓
Good Housekeeping Practices	✓	✓	✓	✓	✓	✓
Gutter Downspout Disconnection	✓					✓
Illicit Dumping Signage					✓	
Irrigation Water Management Plan	✓	✓	✓			
Natural/Native/Drought Resistant Vegetation	✓					
Pesticide Management Plan			✓			
Pond Sampling Plan		✓	✓	✓		
Riprap	✓					
Shoreline Erosion Control	✓					
Storm Sewer Disconnection	✓	✓	✓	✓	✓	✓
Vegetated Swale	✓	✓	✓			✓
Vehicle Washwater Containment						✓

4 **Implementation Costs**

- 5 Cost information, including calculated cost ranges, as well as relative cost in relation to other
 6 practices, O&M, and training for the priority management practices (each expressed relatively
 7 (high, moderate, and low) are illustrated in **Error! Reference source not found.** Costs should be
 8 considered provisional and rough order of magnitude estimates.

9

1

Table A.5. Implementation Costs Associated with Management Practices

Management Practice	Calculated Cost ¹⁵	Relative Cost	O&M Cost	Training Cost	References
Baffle Box	\$90,000 / unit	Moderate	Moderate	Moderate	Vendor quote
Bioretention Cell (Rain garden)	\$85 - \$150 / lineal ft	Low	Low	Low	Puget Sound Action Team (2005)
Road Drainage Improvements	\$2.88 / lineal ft (12' road) (access road repair)	Low	Low	Low	NRCS Pacific Islands Area
Burn Area Emergency Rehabilitation Plan	Variable depending on site conditions and area included	Low	Low	Moderate	National Interagency Fire Center
Conservation Cover	\$718 / ac	Low	Moderate	Low	NRCS Pacific Islands Area
Dam Debris Retrofit	\$85,000 (engineering design)	High	Moderate	Low	RS Means
Fertilizer Management Plan	Variable depending on site conditions and area included	Low	Low	Moderate	College of Tropical Agriculture
Road Realignment and Rebuilding	\$0.25 - \$1.00 / lineal ft	Moderate	Moderate	Low	RS Means, Local Cost Experience
Sediment Retention Basin	\$0.18 / gal	Moderate	Moderate	Low	NRCS Pacific Islands Area
Vegetated Filter Strip	\$1,000 / ac	Moderate	Moderate	Low	NRCS Pacific Islands Area
WWRF Disposal Options					
Extend R-1 Wastewater Network		High	High	Low	Maui DEM (2010)
- Pressurized System Expansion	\$8.78 M				
- Kā'anapali Parkway Expansion	\$6.56 M				
- Lower Honoapi'ilani Road Ext.	\$2.18 M				
- Upper Kā'anapali Condominium Ext.	\$10.69 M				
Deep Injection Wells	Variable depending on scope of project	High	High	High	Engineer Approximations
Submarine Outfall Pipeline	Variable depending on scope of project	High	High	Low	Engineer Approximations
Curb Inlet Basket (with Filter)	\$1800 / unit	Low	Moderate	Low	LA-SMD 2000; USEPA 2003; Field et al. 2004
Debris Removal	Variable depending on scope of project	Moderate	Moderate	Low	Contractor estimate

¹⁵ Includes installation cost unless noted otherwise.

Management Practice	Calculated Cost ¹⁵	Relative Cost	O&M Cost	Training Cost	References
Erosion Control Blanket / Turf Reinforcement Mat	\$2 / sq ft	Moderate	Low	Low	Vendor quote
Facility Stormwater Assessment	\$4,500 / site	Low	Low	Low	Industry
Good Housekeeping Practices	Variable depending on scope of project	Low	Moderate	Moderate	LA-SMD 2000
Gutter Downspout Disconnection	\$6 / linear foot	Low	Low	Low	NRCS
Illicit Dumping Signage	\$350 / sign	Low	Low	Low	Vendor quote
Irrigation Water Management Plan	\$200/acre	Moderate	Low	Low	Vendor
Natural/Native/Drought Resistant Vegetation	\$5 / sq ft	Moderate	Low	Moderate	LA-SMD 2000
Pesticide Management Plan	Variable depending on site conditions and area included	Low	Low	Low	
Pond Sampling Plan	\$1,000	Low	Low	Low	
Riprap	Variable depending on scope of project	High	High	Moderate	
Shoreline Erosion Control	Variable depending on scope of project	High	High	High	
Storm Sewer Disconnection	Variable depending on scope of project	Low	Low	Low	
Vegetated Swale	\$12 / linear foot	Low	Low	Low	RS Means
Vehicle Washwater Containment	Variable depending on site conditions and area included	Moderate	Low	Low	

- 1 **Relative cost** relates the cost of the practice to its performance in terms of reduction of NPS pollutants the practice can be expected to achieve. A “Low” cost
- 2 indicates it costs less per unit for reduction of NPS pollutants compared to the other practices listed. A moderate cost indicates that the cost is balanced roughly
- 3 with the reduction efficiency, and a “High” relative cost means it costs more per unit reduction of NPS pollutant.

- 4 **O&M cost** refers to the amount of labor and expense required to maintain function of the management practice (relative to other management practices). A rating
- 5 of “Low” indicates that the practice does not require much maintenance, “Moderate” implies an average amount of maintenance, and “High” indicates the
- 6 management practice is labor-intensive or otherwise costly to maintain in relation to the other practices listed.

- 7 **Training cost** identifies the costs for time and materials needed to train staff on maintenance protocols to maintain the practices in good, safe and efficient
- 8 operating condition. A rating of “Low” indicates that the practice does not require much training for successful operation; while moderate indicates a balance of
- 9 training to effort for practice success; and “High” indicates the practice is training-intensive to operate and maintain.

1 **A.7. Pollutant Load Reductions**

2 Pollutant load removal efficiency of selected management practices has been the subject of many
 3 studies. There are wide discrepancies in methods for evaluating and quantifying the effectiveness of
 4 management practices. Management practice performance is best described by how much
 5 stormwater runoff is treated and what effluent quality is achieved (Strecker et al. 2001).
 6 Stormwater management practices by definition are specific devices, practices, or methods used to
 7 support the intentions of the stormwater management measure (Field et al. 2004). However this
 8 term lumps widely varying techniques into a single category.

9 NPS pollution is the biggest source of land-based pollution in the Wahikuli and Honokōwai
 10 Watersheds and the management practices recommended will, if implemented, reduce the loads.
 11 Pollutant load reduction estimates were calculated for the watersheds using two primary methods
 12 (*Volume 1: Watershed Characterization*, Section 6.7). The first method used published literature
 13 values to determine relative rates of pollutant loading into the environment for the land uses and
 14 activities occurring within the watersheds (e.g. using University of Hawai'i College of Tropical
 15 Agriculture and Human Resources recommended nutrient application rates per acre for an
 16 agricultural field type and multiplying by the number of acres within the watersheds). This method
 17 was employed when there was limited or no site-specific loading data available to base calculations
 18 upon. The relative load reductions are intended as a general approximation only as the actual loads
 19 released to the environment via land-based transport are unknown in many cases due to other
 20 environmental factors (e.g. actual nutrient loads seen at edge-of-field are unknown due to losses
 21 through the root zone). The second method employed standard engineering formulae to calculate
 22 pollutant loadings whenever empirical data was available (e.g. WWRF pollutant loadings were
 23 calculated by multiplying the measured concentration of a pollutant sampled in the WWRF effluent
 24 by the effluent discharge rate). This method is considered the most accurate for approximating the
 25 pollutant loads within the watersheds.

26 Management practices should address target parameters in management units. Drawing from
 27 multiple guidebooks and engineering judgment, Table presents relative performance of
 28 management practices in addressing pollutant loading and stormwater flow (LA-SMD 2000; EPA
 29 2003; Field et al. 2004; EPA 2005; EPA 2007; EPA 2008a; Bio Clean 2009).¹⁶ The table identifies the
 30 complimentary benefits of various management practices. The actual reduction depends on the
 31 extent of the practice, existing loading levels, and local features like soil and hydrology. Priority
 32 practices that promote the highest comprehensive reduction of the six types include baffle boxes;
 33 bioretention cells; and increasing production and reuse of R-1 water. For secondary practices, good
 34 housekeeping practices also affect reductions substantially.

¹⁶ The *Handbook for Developing Watershed Plans to Restore and Protect Our Waters*, recommends identifying the effectiveness of each management practice in reducing pollutant loading and addressing hydrologic impacts using a scale of high, medium, or low (EPA 2008b).

1

Table A.5. Management Practices and Expected Relative Load Reductions¹⁷

Management Practice	Nutrients	Sediment	Organics	Bacteria	Debris/ Litter	Hydro- carbons
Priority						
Baffle Box	H	H	H	M	H	M
Bioretention Cell (Rain garden)	H	H	H	H	L	H
Burn Area Emergency Rehabilitation Plan	H	H	L	L	L	L
Conservation Cover	H	H	L	L	L	L
Dam Debris Port Retrofit	L	H	L	L	H	L
Fertilizer Management Plan	H	L	L	L	L	L
Road Drainage Improvements	M	H	L	L	L	L
Road Realignment and Rebuilding	M	H	L	L	L	L
Sediment Retention Basin	M	H	M	L	H	L
Vegetated Filter Strip	M	H	M	L	M	L
WWRF Alternate Disposal: Increase Production and Reuse of R-1 Water	H	H	H	H	L	H
Secondary						
Curb Inlet Basket (with Filter)	L	H	L	L	H	L
Debris Removal	L	L	L	L	H	L
Erosion Control Blanket / Turf Reinforcement Mat	M	H	L	L	L	L
Facility Stormwater Assessment	N/A	N/A	N/A	N/A	N/A	N/A
Good Housekeeping Practices	H	H	H	L	H	M
Gutter Downspout Disconnection	L	L	L	L	L	L
Illicit Dumping Signage	L	L	M	M	H	M
Irrigation Water Management Plan	H	H	H	L	L	L
Natural/Native/Drought Resistant Vegetation	L	H	L	L	L	L
Pesticide Management Plan	L	L	H	L	L	L
Pond Sampling Plan	H	M	H	M	L	L
Riprap	L	H	L	L	L	L
Shoreline Erosion Control	L	H	L	M	L	L
Storm Sewer Disconnection	H	H	M	M	H	H
Vegetated Swale	M	H	H	L	L	H
Vehicle Washwater Containment	H	H	L	L	L	H

Pollutant Removal Efficiency of Selected Priority Practices

Pollutant removal efficiency data was available for a typical installation of selected structural management practices: baffle box, conservation cover, bioretention cell, sediment retention basin, and vegetated filter strip. The remainder of the priority practices are non-structural in nature (and their pollutant removal capabilities are dependent on various factors) or there is no data available to determine their efficiency.

¹⁷ Load reductions are expressed as High (H), Medium (M) or Low (L) for the various practices. High is equal to greater than 80 percent reduction; medium is between 50 and 80 percent; and low is less than or equal to 50 percent.

1 Table illustrates the relationship between bioretention cells, sediment retention basins, and
 2 vegetated filter strips and the removal efficiencies of common pollutants generated within the
 3 project area.¹⁸ As shown, all of the practices have significant reductions in the median TSS
 4 concentration. The reduction is greatest for bioretention cells, with an 80% reduction. Bioretention
 5 cells also have the greatest reduction for Total Phosphorus (7.1%) and Total Nitrogen (21%).

6 Pollutant load reductions can be achieved by reducing pollutant concentrations, surface runoff
 7 volumes, and/or a combination of both. For bioretention cells, as an example, the BMP Database
 8 does not show a statistically significant reduction in nitrate concentrations; however, nitrate loads
 9 are expected to be reduced at bioretention sites that effectively reduce volumes discharged to
 10 surface waters.

11 **Table A.6. Selected Priority Management Practice Pollutant Removal Efficiency Data¹⁹**

Constituent	Bioretention Cell			Sediment Retention Basin			Biofilter – Vegetated Filter Strip		
	Inf	Eff	% Red	Inf	Eff	%Red	Inf	Eff	%Red
TSS (mg/L)	50	10	80	64	24	63	51	18	65
Total Phosphorus (mg/L)	0.14	0.13	7.1	0.16	0.21	(+)31	0.12	0.20	(+)66
Total Nitrogen (mg/L)	1.38	1.09	21.0	N/A	N/A	-	0.59	0.62	(+)5.1
Nitrate (mg/L)	0.30	0.23	23	0.63	0.42	33	0.30	0.28	6.7
Fecal Coliform (# / 100 mL)	N/A	N/A	-	749	813	(+)8.55	2,628	4,724	(+)79.76
Total Metals (µg/L)									
Arsenic	N/A	N/A	-	2.5	1.8	28	0.9	1.0	(+)11
Cadmium	N/A	N/A	-	0.5	0.5	0	0.5	0.2	60
Chromium	N/A	N/A	-	6.7	3.2	52	4.9	2.7	45
Copper	18	9	50	10	7	30	24	7	70
Lead	N/A	N/A	-	10.0	5.0	50	8.6	2.0	77
Nickel	N/A	N/A	-	6.5	3.7	43	4.9	2.9	41
Zinc	74	20	73	66	24	64	99	24	76

12 In Section 6.7.1.2 of *Volume 1*, RUSLE2 was used as a tool for predicting long term annual average
 13 rates (soil loss) of rill erosion on the agricultural fields within the watersheds. Estimates of soil
 14 losses from the three representative seed corn fields were significantly higher when compared to
 15 the estimates from the active coffee, and fallow sugarcane and pineapple fields. Implementing the
 16 priority practice of conservation cover on bare, fallow seed corn fields will affect the crop
 17 vegetation and management factor (C) in the equation, which represents crop type, tilling, and
 18 management related to field production. An increased C value results in higher expected soil loss.
 19 As shown in Table , theoretical C values for grass or grass-like plants can vary substantially. For
 20 example, bare soil has a theoretical C value of 0.45 (0% soil cover), while if 60% of the surface is
 21 covered with grass, grass-like plants, or decaying compacted plant litter, a C value of 0.042 can be

¹⁸ The International Stormwater BMP Database contains results of stormwater BMP studies independently conducted and provided by researchers throughout the U.S. and other countries. The database provides the median influent and effluent event mean concentrations, for commonly reported constituent and BMP categories (updated November 2011). <http://www.bmpdatabase.org/Docs/BMP%20Database%20Tabular%20Summary%20November%202011.pdf>

¹⁹ From International Stormwater BMP Database, <http://www.bmpdatabase.org/>

1 achieved; a factor of approximately 10 less. This would influence estimates of land soil loss
 2 proportionally (if all other variables are kept constant).

3 **Table A.7. Cover Factor C Values for Established Plants²⁰**

	Percentage of surface covered by residue in contact with the soil					
	0%	20%	40%	60%	80%	95%
C factor for grass, grass-like plants, or decaying compacted plant litter	0.45	0.20	0.10	0.042	0.013	0.0003
C factor for broadleaf herbaceous plants (including most weeds with little lateral root networks) or undecayed residue	0.45	0.24	0.15	0.091	0.043	0.011

²⁰ <http://www.cdrpc.org/NET/WQ/ErosANDsed/3rusle.pdf>

Appendix B. Priority Management Practices

Priority management practices are recommended for implementation as soon as funding and resources are available. Prior to implementation, some of the recommended management practices will require detailed design work based on the complexity of the measure, site physiographic conditions, and land ownership and regulatory considerations. Other practices will be straightforward and easily implemented once any regulatory considerations have been addressed. Design considerations are outlined in this appendix for selected management practices, however the WHWMP is not intended to be a design manual for management practices. There are numerous publications and resources to guide land managers and designers in the selection, acquisition, and installation of management practices.

Resources

A Handbook for Stormwater Reclamation and Reuse Best Management Practices in Hawaii, December 2008

www.state.hi.us/dlnr/cwrm/planning/hsrar_handbook.pdf

Low Impact Development, A Practitioner's Guide, June 2006

http://hawaii.gov/dbedt/czm/initiative/lid/lid_guide_2006.pdf

EPA's National Pollution Discharge Elimination System (NPDES) Stormwater Program

http://cfpub.epa.gov/npdes/home.cfm?program_id=6

International Stormwater BMP Database

<http://www.bmpdatabase.org/>

Center for Stormwater Protection

<http://www.cwp.org/your-watershed-101/stormwater-management.html>

Installation Tasks

Table identifies some of the required tasks for each of the priority management practices.

Table B.1. Priority Management Practice Installation Tasks

Management Practice	Location Logistics	Drainage size	Construction	Community Acceptance	O&M	Permits	Land Owner / Manager Support	Education / Outreach	Municipal Support
Baffle Box	X	X	X		X	X			X
Bioretention Cell (Rain garden)	X	X	X	X	X	X	X	X	
Burn Area Emergency Rehabilitation Plan							X	X	
Conservation Cover					X		X		
Dam Debris Retrofit	X	X	X	X	X	X			X
Fertilizer Management Plan				X	X		X	X	
Road Drainage Improvements	X		X		X		X		
Road Realignment and Rebuilding	X		X		X				

Management Practice	Location Logistics	Drainage size	Construction	Community Acceptance	O&M	Permits	Land Owner / Manager Support	Education / Outreach	Municipal Support
Sediment Retention Basin	X	X	X		X	X	X		
Vegetated Filter Strip					X		X		
WWRF Alternate Disposal: Increase Production and Reuse of R-1 Water	X		X	X	X	X			X

1

1 **B.1. Baffle Box**

2 **Description**

3 The Nutrient Separating Baffle Box is a multi-chambered concrete box separated with baffles used
 4 to settle out pollutants. Chambers can be fitted with absorbent membranes to trap floating
 5 pollutants, e.g. hydrocarbons. Effective at removing sediments, TSS, and hydrocarbons, this system
 6 is specially designed to capture trash, debris, organics, and gross solids in a raised screening basket
 7 that allows these pollutants to be stored in a dry state.

8 Baffle boxes are a treatment practice that can provide water quality benefits to stormwater runoff
 9 that has entered the Urban Unit's S4. This is accomplished through filtering and trapping of
 10 sediments and other NPS pollutants contained in the runoff within the baffle box, prior to runoff
 11 exiting the system into manmade or natural channels. This includes hardened concrete channels
 12 that convey runoff from basins or have replaced the natural stream channels that once flowed
 13 through the region. Baffle boxes are essentially a retro-fit to the S4 and are expected to significantly
 14 and immediately reduce the concentration of fine sediments, nutrients, and other NPS pollutants.

15 **Design Considerations**

16 Baffle boxes should be installed in S4's that receive elevated levels of sediment and nutrient laden
 17 runoff from contributing drainage areas to reduce NPS pollutants conveyed in the S4. Priority
 18 should be given to installations where an S4 discharges directly to the coastal environment or
 19 water bodies without any treatment practices in place to treat the runoff. The location of baffle box
 20 installation within an S4 system should be at an accessible point above the stormwater outfall.

21 The use of curb inlet baskets on the same pipe network as baffle boxes is somewhat redundant and
 22 not necessary. When a baffle box is placed near the outfall of a pipe network it will treat all the
 23 runoff entering the upstream inlet structures on the same pipe network and will preclude the need
 24 for pollution removal devices in these structures. However, pollutants accumulated within the
 25 baffle boxes must be removed and the unit maintained in order for the practice unit to remove
 26 pollutants from the S4. If baffle boxes are not installed within an S4, then it is strongly
 27 recommended that curb inlet baskets with filters be installed (Appendix C.1).

28 Existing utilities (e.g. drainage, electric, sewer, water) must be marked by the appropriate
 29 authorities before design of the baffle box, any excavation, or site preparation takes place.
 30 Additionally, elevations of existing pipes within the drainage system must be verified for in-line
 31 design and construction of unit. This will ensure that existing utility networks will not be adversely
 32 impacted, as well as protect the health and well-being of personnel involved with the project.

33 Bio Clean Environmental Services, Inc. (Bio Clean) is a baffle box manufacturer that has worked
 34 with municipal entities on installations in Hawai'i. The Bio Clean baffle box can be customized to
 35 trap up to 95% of the sediment routed into its three chamber design. Based on the documented
 36 performance of this manufacturer's product, baffle boxes from Bio Clean are recommended.²¹ The
 37 Bio Clean baffle box is designed to trap both coarse and fine sediments, filter nutrients, and capture
 38 hydrocarbons, and is relatively easy to maintain using conventional vacuum equipment.

²¹ Details can be found at http://www.biocleanenvironmental.com/product/ns_baffle_box.

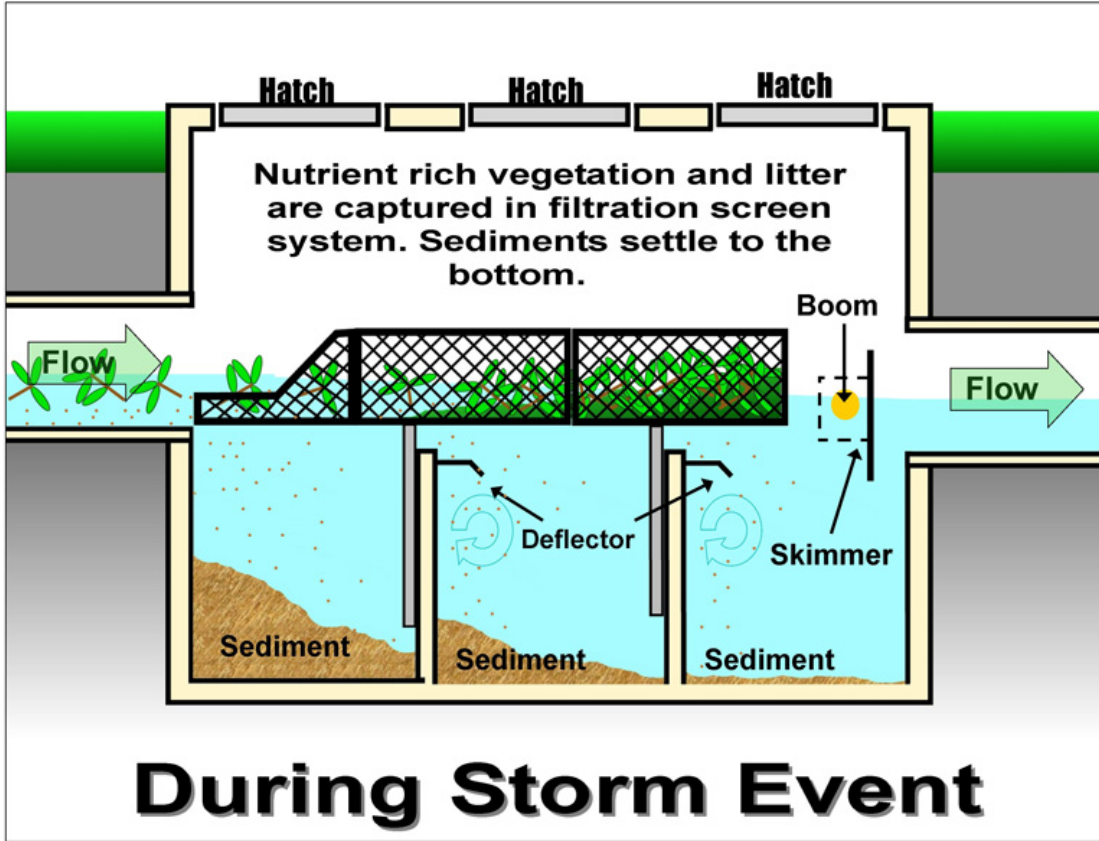

1



2

1 **B.2. Bioretention Cell (Rain Garden)**

2 **Description**

3 A bioretention cell, or rain garden, is a low-impact development measure that is placed along the
 4 flow path of storm water runoff where it captures and treats stormwater containing pollutants. It is
 5 comprised of shallow depression excavated and backfilled with media used to promote infiltration
 6 and support plants that are installed to both physically trap and bioremediate pollutants. This
 7 system detains the volume of stormwater runoff that typically contains high pollutant loadings.
 8 Known as the “first flush,” this portion of rainfall generated on impervious and other areas of
 9 reduced infiltration is treated within the bioretention cell through chemical processes that include
 10 plant root uptake and soil retention.

11 Natural landscaping is one of the land development techniques to be emphasized within the
 12 environment of West Maui (Maui County Council 1996). Bioretention cells fit into the environment
 13 very well as soft design features incorporating vegetative areas.

14 Bioretention cells can be installed alone or as part of a treatment chain of management practices
 15 within the Urban Unit. They help to break up the DCIA that is associated with the extensive
 16 impervious areas of resorts, shopping plazas, industrial areas, and roadways. They also will
 17 function to disconnect the S4 network at specific locations within the Urban Unit and promote
 18 infiltration of stormwater runoff into pervious soils present on the developed properties. They also
 19 create strategic S4 disconnection points, which results in reductions of runoff volume, peak flow,
 20 and pollutant loadings to the coastline.

21 Incorporating bioretention into a site development project can be more cost effective over the
 22 lifetime of the project when compared to the traditional method of S4 drainage construction.

23 Hui o Ko’olaupoko, a not-for-profit watershed advocacy group on O’ahu, is developing a rain garden
 24 working manual for the use in the Hawaiian Islands. This resource is expected to be a complete user
 25 guide for designing and installing rain gardens. <http://www.huihawaii.org/>

26 **Design Considerations**

27 Bioretention cells typically have a grass filter strip running along the edge of their width to trap
 28 sediment generated on the surface of the drainage area that contributes runoff to the system.
 29 Runoff should sheet flow over a grass filter strip area into bioretention areas without the use of
 30 catch basins or closed system piping networks, reducing both construction and maintenance costs
 31 associated with stormwater infrastructure over the life of the project. This will allow sediment
 32 suspended in the stormwater to settle out and avoid clogging of the system. When properly sited
 33 and constructed, bioretention can require little maintenance over an extended service life, resulting
 34 in reductions to pollutant loadings that would otherwise be conveyed downstream through
 35 traditional closed drainage piping networks and natural stream channels.

36 ***Depth to Groundwater Table***

37 Bioretention is most appropriate for use as a management practice in locations where the
 38 groundwater table is several feet below the ground surface to avoid stagnant ponding of runoff on
 39 the ground surface and to ensure infiltration into the bioretention soil mixture and underlying site

1 soils. An excavated test pit may be necessary to determine the high water table if data is not already
2 available for the site. Groundwater depths can vary significantly across large parcels based on a
3 number of factors including topography and proximity to coastal waters.

4 ***Soil Infiltration Rate***

5 A soil infiltration test must be performed at each proposed bioretention location to determine
6 suitability of the management practice for that location, as well as design details for the installation.
7 While general soil types and corresponding infiltration rates can be obtained from a variety of
8 sources for a given geographical area, in situ conditions vary greatly, often within just a few feet on
9 a particular site.

10 ***Suitable Plantings***

11 Suitable planting selection must be made based on the rainfall for each specific bioretention
12 placement location. Within the Urban Unit, bioretention cells may be best planted with species that
13 can easily assimilate into the existing landscape. Rainfall frequency and intensity varies greatly
14 across the project area; careful consideration must be made to properly select plantings.

15 ***Use of Underdrain and Overflow Control Structure***

16 Depending on presence of underground utilities, underlying soil characteristics, and other site
17 constraints, it may be necessary to install an underdrain below the bioretention soil mix to convey
18 infiltrated water from the cell to a suitable outlet point. If an underdrain is used, it should be
19 properly sized for the contributing volume of runoff predicted at the design storm event to the
20 bioretention cell. A soil analysis should be performed at each bioretention cell location, to
21 determine whether the underlying soils can naturally infiltrate the runoff that will percolate
22 through the bioretention soil mix, or if an underdrain should be utilized to direct stormwater into a
23 closed drainage system or stabilized outlet.

24 If an underdrain is used, the bioretention cell must discharge the treated runoff to either the
25 existing closed drainage system within the site, or daylight into an existing drainage course or
26 natural channel. Depending on the location of the bioretention cell, this may necessitate
27 construction of a piping network to convey the stormwater to the suitable location. Cells that do not
28 utilize underdrains are fully infiltrating and do not require a piped outlet. If daylighting into a
29 drainage course is possible, incorporation of a vegetated swale prior to connection into the system
30 will provide further treatment of runoff.

31 An overflow control structure can convey flow at larger storm events directly into the closed
32 drainage system that the bioretention cell is connected to if an underdrain is used. This structure
33 can be a raised catch basin with grate located above the level of ponding required to handle the
34 infiltration of the first flush runoff event. If an underdrain is not incorporated into the design, an
35 overflow structure may still be required to convey runoff offsite in the event of flooding or
36 compromise to the infiltration capacity of the cell.

37 Any work done below the high water line (e.g. outletting of underdrain piping) would most likely
38 trigger the Section 404 US Army Corps of Engineers permitting process relating to discharge of
39 dredged or fill material.

40

1 **Grading**

2 Bioretention is recommended for placement in areas where existing grades are as close to level as
 3 possible. While cells can be constructed in moderately sloped areas, care should be taken to orient
 4 the bioretention cell so that its longitudinal length runs along the contour, and the surface of the
 5 cell is level across its length to promote sheet flow of runoff into the cell and discourage
 6 channelization. Runoff should enter the cell along its width, and not from the ends.

7 **Contributing Drainage Area**

8 Bioretention cells should be sized and located on the site to handle the volume and rate of
 9 stormwater runoff generated on the contributing drainage area. Impervious, turf, agricultural fields,
 10 and other cover types within the project area have varying infiltration and runoff generation
 11 characteristics that factor into the calculations for proper sizing of bioretention areas.

12 Bioretention relies on infiltration of runoff through its surface into the underlying soil mix below,
 13 and as such it is critical that the drainage areas contributing runoff to the cells not be subject to
 14 activities that could release sediment into the cell via rainfall, irrigation, or other runoff events.
 15 Clogging of the bioretention cell can cause ponding, loss of infiltration capacity, and reduction of
 16 water quality treatment.

17 **Available Land Area for Construction**

18 Sufficient land must be available for construction that allows for placement of both the bioretention
 19 area and grass filter strips without removal of mature trees and avoiding potential impact from
 20 vehicular or pedestrian impacts, and the associated sediment generation associated with these
 21 impacts. Within the Urban Unit, bioretention is suited well for placement between impervious
 22 parking lots and adjacent to paved roadways where there are currently areas of landscape
 23 plantings, turf, or unstabilized soils. Areas at resorts where there are high levels of vehicle egress
 24 are recommended for bioretention siting. The majority of oils and grease from vehicles parked and
 25 traveling within these areas can be captured and contained within the bioretention cells onsite for
 26 treatment (An example of a desirable construction area is in proximity to parking areas near
 27 building entrances, rather than in overflow parking areas where few cars typically park).

28 **Location of Existing Utilities**

29 Existing utilities (e.g. electric, sewer, water) must be marked by the appropriate authorities before
 30 any excavation or site preparation takes place. This will ensure that existing utility networks will
 31 not be adversely impacted, as well as protect the health and well-being of personnel involved with
 32 the project.

33 **Long-term Maintenance**

34 Bioretention cells are meant to be self-sustaining and require minimal resources over the life of the
 35 project for maintenance related upkeep. However, long-term maintenance requirements may
 36 include: readily available water source for manual irrigation of cell (if plants require it; depending
 37 on individual site climate conditions); and replacement of mulch surface layer of cell in the event of
 38 disturbance or fouling due to sediment accumulation.

39

1 **Pedestrian Egress Routes**

2 Placement of boulders or other boundary items to discourage the passage of pedestrians through
3 the rain garden en route to the shoreline will help minimize trampling of the bioretention cell
4 surface and allow the plants to develop healthy stands.

5 **Bioretention Cell Detail**

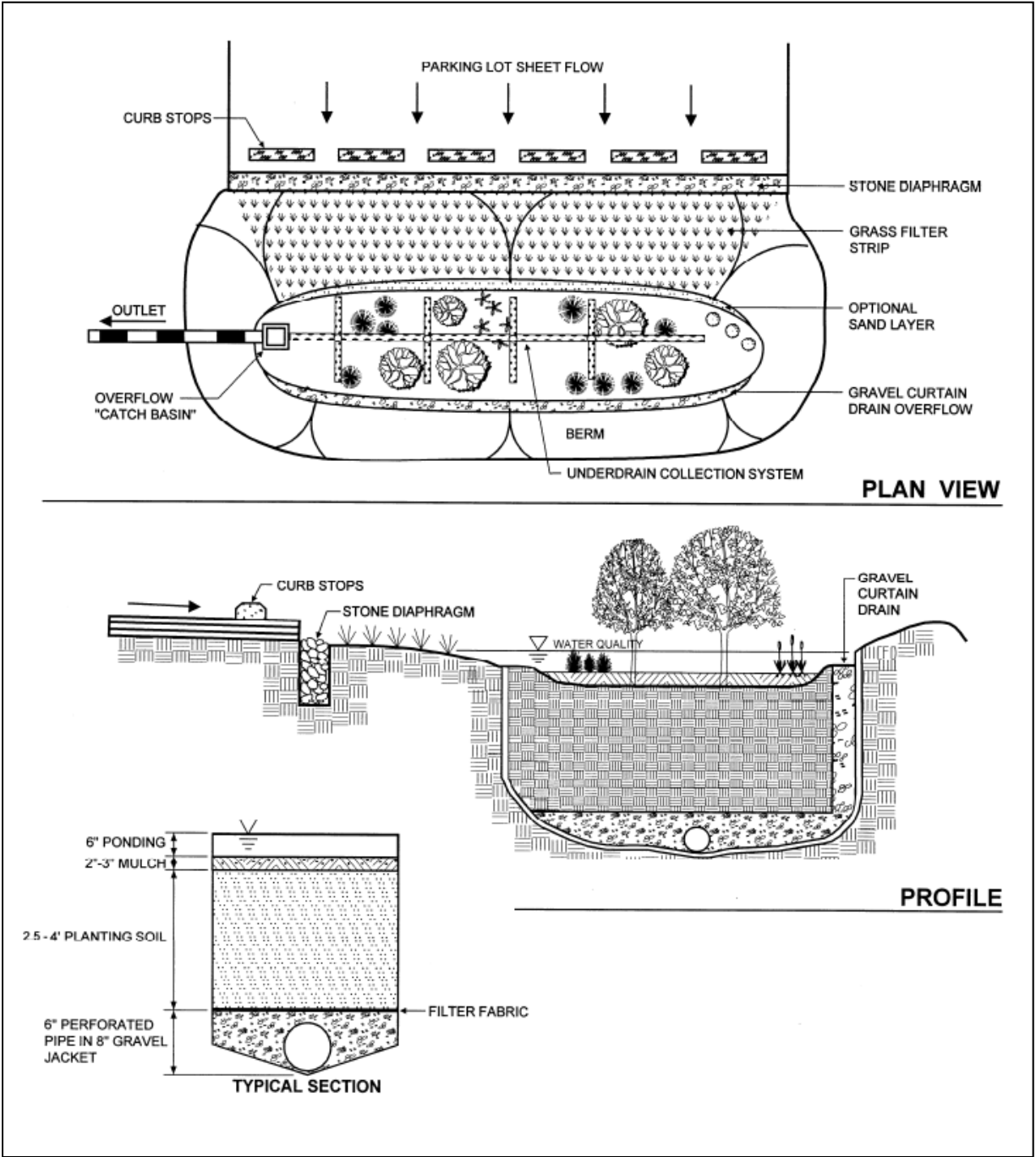

6
7 Note: Graphical representation only; not actual design.
8 (from Vermont Stormwater Treatment Manual, http://www.vtwaterquality.org/cfm/ref/ref_stormwater.cfm)

1 **B.3. Road Drainage Improvements**

2 **Description**

3 Broad based dips and water bars are designed to direct runoff off of unpaved roads before it has
 4 a chance to channelize and cause erosion within the roadway. The design intent is for runoff to be
 5 periodically directed to a low point within the road and then sloped to the downstream side of the
 6 road, where a stabilized outlet receives the flow. The main difference between broad based dips
 7 and water bars is that for dips the road grade typically curves at the low point, whereas for water
 8 bars, a small ditch is usually constructed at the low point.

9 **Design Considerations**

10 ***Spacing***

11 Broad based dips and water bars should be placed at an appropriate spacing interval that follows
 12 national NRCS Conservation Practice Standards. Chart 1 shows recommended spacing of water bars
 13 based on road grade and soil type (NRCS 2010). The Maui NRCS office tends to take a more
 14 conservative approach and reduces the spacing by an additional appropriate length to ensure there
 15 is no shortcutting of drainage between the structures (C. Hashimoto, pers. comm.).

16 It may also be necessary to design drainage structures to accommodate the new dips and water
 17 bars. If this is the case, the minimum design frequency for the access roads is the 2 year, 24-hour
 18 storm event (NRCS 2010). NRCS specifies that grades for access roads should not exceed 10%
 19 except for short lengths, and only exceed 18% when necessary for field access roads. Water bars
 20 should typically be utilized on steep grades (>10%). As discussed in Section 3.1, the priority of
 21 roads in need of repair and the site layout of practices will be developed during the inventory and
 22 assessment phase of the road repairs.

23 Broad based dips will be located based on the contributing drainage area and roadway slope. This
 24 will help prevent runoff from channelizing within the roadway. Limited space between the access
 25 roads and the adjacent fields will most likely require existing field drainage channels to be utilized
 26 for discharge of road runoff. Due to the varying frequency and specific type of drainage used for
 27 each of the field types, it will most likely be necessary to synchronize the spacing frequency of
 28 broad based dips with the current location of field drainage practices on a field by field basis. For
 29 example, within the fallow pineapple field region, broad based dips should be incorporated to the
 30 greatest extent possible wherever there are existing terraces already in place to divert surface
 31 discharge.

32 ***Outlet Stabilization***

33 Both broad based dips and water bars should have vegetated or stone/riprap stabilization at the
 34 point of discharge for the road runoff. Limited space between the roads and the adjacent fields will
 35 mostly exclude the use of a separate drainage outlet channel and require the stabilization of
 36 existing field drainage channels where runoff enters the channel. For example, within the fallow
 37 pineapple field region, stabilizing the intersection of the broad based dip or water bar and the
 38 beginning of the terrace with riprap and underlying geotextile will reduce erosive velocities of
 39 runoff into the terraces. Broad based dips can also be installed in conjunction with sediment

1 retention basins to promote improved sediment retention onsite. The dips can flow into basins,
 2 which then can be outletted into a stabilized terrace or channel.

3

4 **Chart 1. Recommended Spacing of Relief Culverts and Water Bars Based on Soil Types**

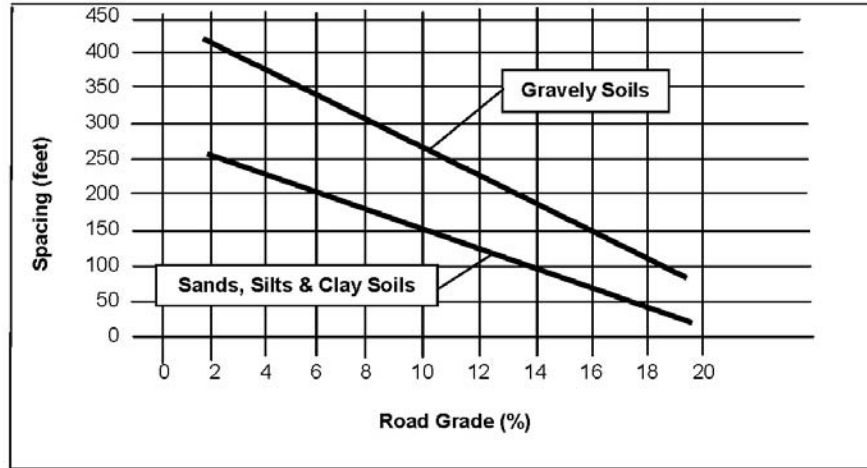

5

Broad Based Dip

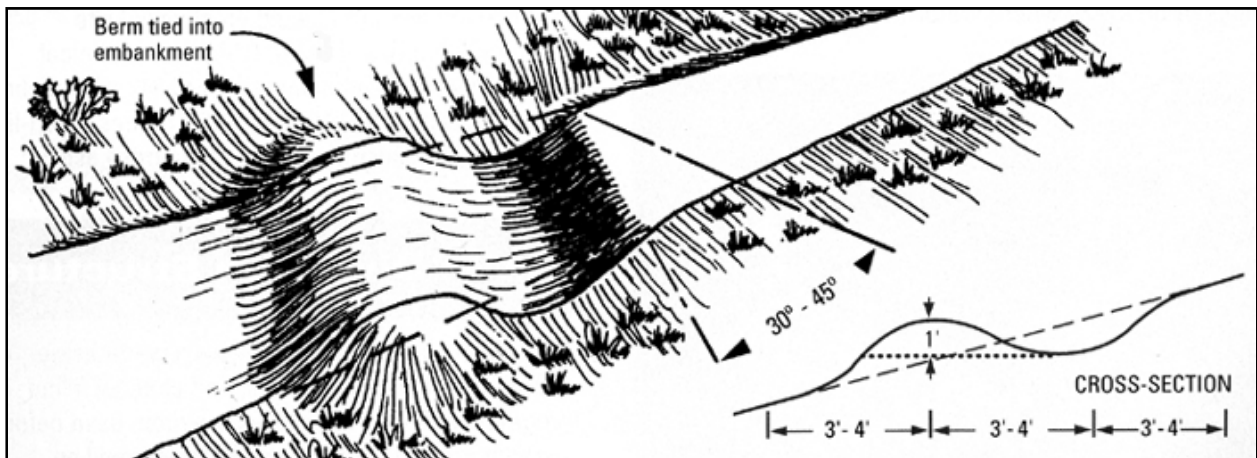

6

7

1

Rolling Dip and Waterbar

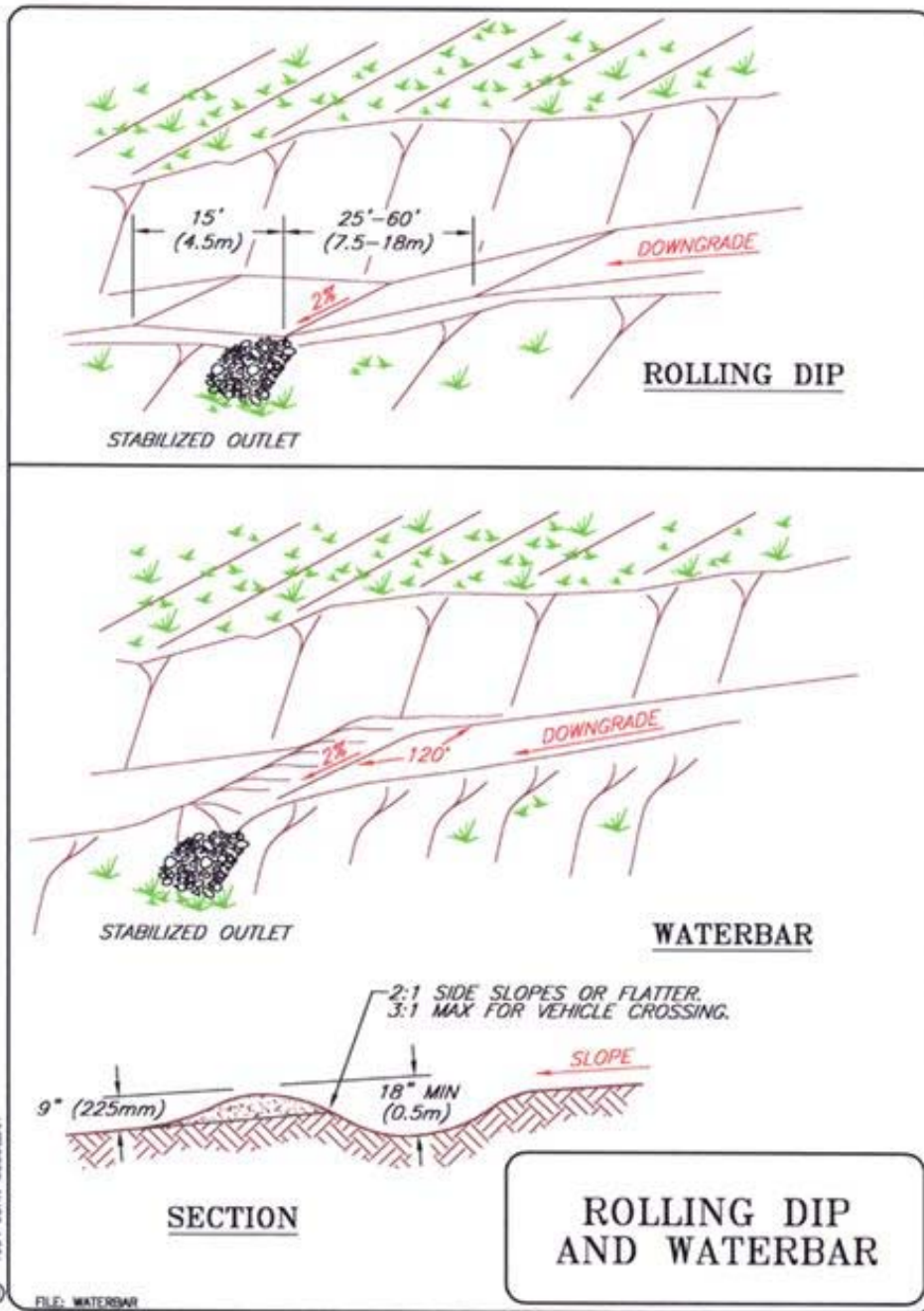

2

3

1

Outslope Road

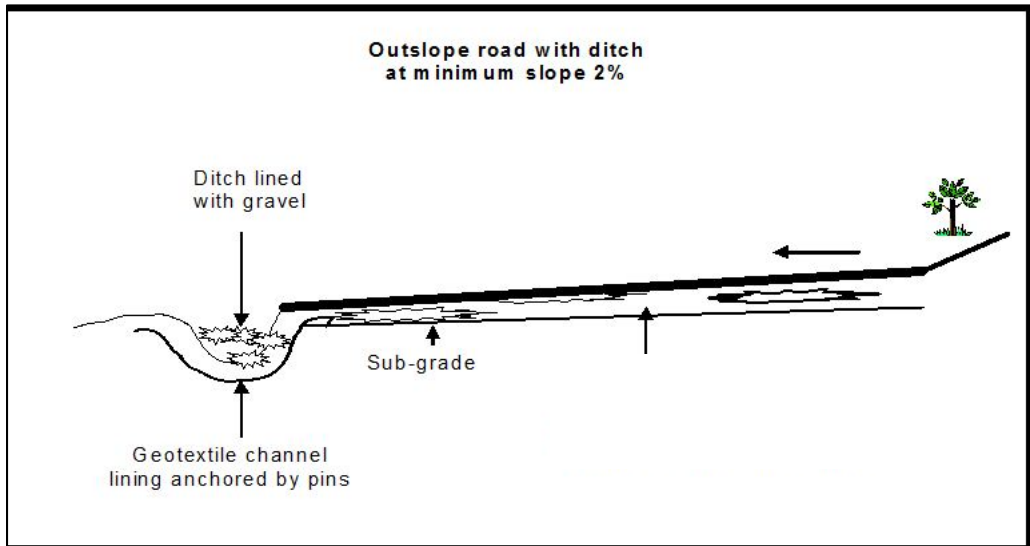

2

3

Crown Center Road

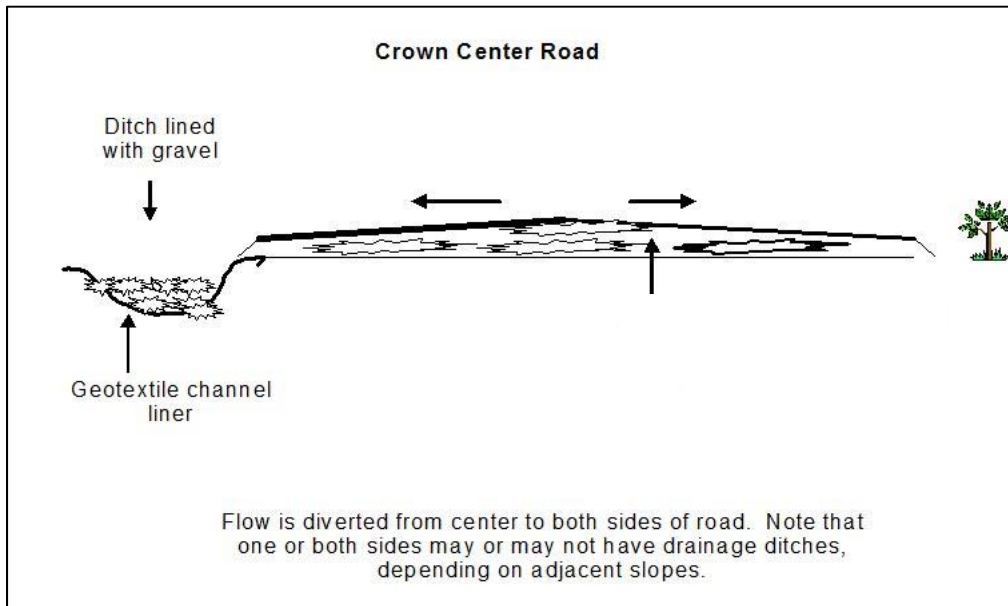

4

5

Detailed Cost Information for Road Inventory/Assessment and Installation

Tables B.2 and B.3 provide a detailed breakdown, by subwatershed of the estimated costs to conduct the inventory/assessment and install management practices.

Table B.2. Details on Management Practices by Subwatershed

Subwatershed	Honokao'o 5	Honokao'o 6	Honokōwai	Keka'a	Lagoons	Mahinahina	Pohaku	Wahikuli
Minimum Road Slope (%) ¹	1.9	0.0	2.8	3.5	0.0	2.4	1.7	0.0
Maximum Road Slope (%) ¹	62.3	12.7	74.3	65.1	11.6	140.5	14.6	103.1
Mean Road Slope (%) ¹	11.5	6.5	12.9	11.7	6.2	14.1	8.0	15.6
Total Road Length (ft) ²	101,592	32,883	121,053	40,501	12,094	101,842	14,833	109,687
Total Road Length (mi) ²	19	6	23	8	2	19	3	21
Number of Waterbars/Dips ³	398	96	520	160	35	481	47	588
Number of Detention Basins ⁴	159	38	208	64	14	193	19	235
Length of Ditches (ft) ⁵	20,318	6,577	24,211	8,100	2,419	20,368	2,967	21,937
Number of Energy Dissipators ⁶	159	38	208	64	14	193	19	235
Surface Area of Waterbars/Dips (ft ²) ⁷	59,631	14,421	78,063	24,011	5,231	72,199	7,042	88,161
Surface Area of Detention Basins (ft ²) ⁸	49,931	12,075	65,365	20,105	4,380	60,454	5,896	73,820
Volume of Ditches Excavated (ft ³) ⁹	20,318	6,577	24,211	8,100	2,419	20,368	2,967	21,937
Surface Area of Energy Dissipator (ft ²) ¹⁰	1,590	385	2,082	640	139	1,925	188	2,351
Inventory/Assessment (days) ¹¹	5	2	6	2	1	5	1	5

Notes:

¹ Road slopes calculated in ArcGIS using slope map created with 10m Digital Elevation Model.

² Road length based on dirt roads identified in field and in high resolution GIS images, and delineated in ArcGIS.

³ Spacing calculated based on road grade. Final count assumes 50% of road length requires waterbars/dips.

⁴ Final count assumes 40% of waterbars/dips fitted with detention basins.

⁵ Assume 20% of total road length needs ditches.

⁶ Assume 40% of waterbars/dips need energy dissipaters.

⁷ Assume road width of 15 feet, length of work on road of 10 ft, equaling total area 150 ft² for each waterbar/dip.

⁸ Assume detention basin roughly circular with a radius of 10 ft, equaling 314 ft² for each.

⁹ Volume of fill excavated per unit length of ditch is product of excavation area times ditch length with maximum depth of 2 feet.

¹⁰ Assume 10 ft² for each.

¹¹ Assumes 4 miles per day (rounded up).

1 **Table B.3. Detailed Costs for Road Inventory/Assessment and Installation by Subwatershed**

ITEM DESCRIPTION	QUANTITY		MATERIALS & LABOR		TOTAL
	TOTAL QTY	U/M	UNIT COST	COST	COST ²²
Honokowai Subwatershed					
Labor (Engineering Services) ¹	6	DAY	1,600	9,600	9,600
Contingency 5%					480
HI GET (4.166%)	4.166%				420
Phase 1: Inventory/Assessment					10,500
Waterbars/Dips ²	78,063	ft ²	0.24	18,735	18,735
Retention Basin ²	65,365	ft ²	0.31	20,263	20,263
Ditches ²	24,211	ft ³	0.31	7,505	7,505
Energy Dissipators ²	2,082	ft ²	0.24	500	500
Mobilization/Demobilization	1	LS	4,500	4,500	4,500
Subtotal all roads					51,503
Contingency 5%					2,575
HI GET (4.166%)	4.166%				2,253
Phase 2: Installation					56,331
Total Honokowai Subwatershed					66,831
Mahinahina Subwatershed					
Labor (Engineering Services)	5	DAY	1,500	7,500	8,000
Contingency 5%					400
HI GET (4.166%)	4.166%				350
Phase 1: Inventory/Assessment					8,750
Waterbars/Dips	72,199	ft ²	0.24	17,328	17,328
Retention Basin	60,454	ft ²	0.31	18,741	18,741
Ditches	20,368	ft ³	0.31	6,314	6,314
Energy Dissipators	139	ft ²	0.24	33	33
Mobilization/Demobilization	1	LS	4,500	4,500	4,500
Subtotal all roads					46,916
Contingency 5%					2,346
HI GET (4.166%)	4.166%				2,052
Phase 2: Installation					51,314
Total Mahinahina Subwatershed					60,064
Pohakukaanapali Subwatershed					
Labor (Engineering Services)	1	DAY	1,600	1,600	1,600
Contingency 5%					80
HI GET (4.166%)	4.166%				70
Phase 1: Inventory/Assessment					1,750
Waterbars/Dips	7,042	ft ²	0.24	1,690	1,690
Retention Basin	5,896	ft ²	0.31	1,828	1,828

²² The cost estimates were prepared using standard guidance documents, cost reference documents, and local pricing information compiled from other construction projects in Hawai'i. Reference documents include the 2012-13 edition of R.S. Means Cost Data book, NRCS cost data, and information supplied by equipment and material suppliers. Estimates are approximate and should be considered provisional.

ITEM DESCRIPTION	QUANTITY		MATERIALS & LABOR		TOTAL
	TOTAL QTY	U/M	UNIT COST	COST	COST ²²
Ditches	2,967	ft ³	0.31	920	920
Energy Dissipators	188	ft ²	0.24	45	45
Mobilization/Demobilization	1	LS	4,500	4,500	4,500
Subtotal all roads					8,983
Contingency 5%					449
HI GET (4.166%)	4.166%				393
Phase 2: Installation					9,825
Total Pohakukaanapali Subwatershed					11,575
Wahikuli Subwatershed					
Labor (Engineering Services)	6	DAY	1,600	9,600	9,600
Contingency 5%					480
HI GET (4.166%)	4.166%				420
Phase 1: Inventory/Assessment					10,500
Waterbars/Dips	88,161	ft ²	0.24	21,159	21,159
Retention Basin	73,820	ft ²	0.31	22,884	22,884
Ditches	21,937	ft ³	0.31	6,801	6,801
Energy Dissipators	2,351	ft ²	0.24	564	564
Mobilization/Demobilization	1	LS	4,500	4,500	4,500
Subtotal all roads					55,908
Contingency 5%					2,795
HI GET (4.166%)	4.166%				2,446
Phase 2: Installation					61,148
Total Wahikuli Subwatershed					71,648
Honokaoo 5 Subwatershed					
Labor (Engineering Services)	5	DAY	1,600	8,000	8,000
Contingency 5%					400
HI GET (4.166%)	4.166%				350
Phase 1: Inventory/Assessment					8,750
Waterbars/Dips	59,631	ft ²	0.24	14,311	14,311
Retention Basin	49,931	ft ²	0.31	15,479	15,479
Ditches	20,318	ft ³	0.31	6,299	6,299
Energy Dissipators	1,591	ft ²	0.24	382	382
Mobilization/Demobilization	1	LS	4,500	4,500	4,500
Subtotal all roads					40,971
Contingency 5%					2,049
HI GET (4.166%)	4.166%				1,792
Phase 2: Installation					44,811
Total Honokaoo 5 Subwatershed					53,561
Honokaoo 6 Subwatershed					
Labor (Engineering Services)	2	DAY	1,600	3,200	3,200
Contingency 5%					160
HI GET (4.166%)	4.166%				140

ITEM DESCRIPTION	QUANTITY		MATERIALS & LABOR		TOTAL
	TOTAL QTY	U/M	UNIT COST	COST	COST ²²
Phase 1: Inventory/Assessment					3,500
Waterbars/Dips	14,421	ft ²	0.24	3,461	3,461
Retention Basin	12,075	ft ²	0.31	3,743	3,743
Ditches	6,577	ft ³	0.31	2,039	2,039
Energy Dissipators	385	ft ²	0.24	92	92
Mobilization/Demobilization	1	LS	4,500	4,500	4,500
Subtotal all roads					13,836
Contingency 5%					692
HI GET (4.166%)	4.166%				605
Phase 2: Installation					15,132
Total Honokaoo 6 Subwatershed					18,632
Kekaa Subwatershed					
Labor (Engineering Services)	2	DAY	1,600	3,200	3,200
Contingency 5%					160
HI GET (4.166%)	4.166%				140
Phase 1: Inventory/Assessment					3,500
Waterbars/Dips	24,011	ft ²	0.24	5,763	5,763
Retention Basin	20,105	ft ²	0.31	6,233	6,233
Ditches	8,100	ft ³	0.31	2,511	2,511
Energy Dissipators	640	ft ²	0.24	154	154
Mobilization/Demobilization	1	LS	4,500	4,500	4,500
Subtotal all roads					19,160
Contingency 5%					958
HI GET (4.166%)	4.166%				838
Phase 2: Installation					20,956
Total Kekaa Subwatershed					24,456
Lagoons Subwatershed					
Labor (Engineering Services)	1	DAY	1,600	1,600	1,600
Contingency 5%					80
HI GET (4.166%)	4.166%				70
Phase 1: Inventory/Assessment					1,750
Waterbars/Dips	5,231	ft ²	0.24	1,255	1,255
Retention Basin	4,380	ft ²	0.31	1,358	1,358
Ditches	2,419	ft ³	0.31	750	750
Energy Dissipators	139	ft ²	0.24	33	33
Mobilization/Demobilization	1	LS	4,500	4,500	4,500
Subtotal all roads					7,897
Contingency 5%					395
HI GET (4.166%)	4.166%				345
Phase 2: Installation					8,637
Total Lagoons Subwatershed					10,387

1 Notes: ¹ Cost based 2 person crew (1 engineer or equivalent at \$120/hr and 1 technician at \$80/hr) for 8 hour day.
 2 ² Costs from NRCS Pacific Islands Area.

1 **B.4. Road Realignment and Rebuilding**

2 **Description**

3 Re-engineering of access roads involves restoration and maintenance of the existing road network,
 4 in the form of realignment, grading and repair, and relocation. The original layout of the road
 5 network maximized field acreage while minimizing space used for egress routes. As a result, roads
 6 are typically narrow and on variable terrain, and subject to degradation over time. Whether roads
 7 are actively used today, or have low to no current use, they are subject to disrepair and should be
 8 repaired and maintained. An inventory should be conducted of access roads to determine which
 9 mode of repair applies to individual road segments. This management practice applies to all roads
 10 within Honokōwai and Wahikuli Watersheds that are in disrepair and contributing sediment loads
 11 as a result of degradation. Coordination between the multiple landowners within each watershed,
 12 an agreement for which fields are priorities to retain for vehicular access to fields and properties,
 13 and which roads can be removed to improve watershed health may be a necessary step for all
 14 parties to be in agreement.

15 ***Repair and Regrading of Active Access Roads***

16 For roads currently in use, and realignment or relocation is not an option, then existing rills, gullies,
 17 and channels that have formed in these roads should not be simply filled in, but rather the road
 18 regraded so that repeated erosion does not form in the same location. Vehicle travel over these
 19 roads compacts and deepens ruts that have formed from erosion. Roads should graded super-
 20 elevated to one side wherever possible, so that gullies do not form in the center of the road surface
 21 and damage significant lengths of road.

22 ***Realignment/Relocation of Low Use Access Roads***

23 The low use access roads are those that infrequently used and are at high risk of erosion and rapid
 24 conveyance of runoff due to their *makai* (ocean)/*mauka* (inland) alignment and/or condition. The
 25 roads may run either from the Urban Unit boundary into the upper reaches of the Agricultural Unit
 26 in a similar fashion to actively used roads, or they run between fields themselves.

27 Realignment and/or relocation involves either the vertical regrading or horizontal repositioning (or
 28 both) of low use access roads. Realignment and relocation of low use access roads results in
 29 minimizing steep grades, promoting soil stability, and reducing erosive potential of soils. In some
 30 cases it may be possible to ease the road grade transition between steep and gradual grades,
 31 resulting in a curved road in place of sharp transitions that currently spur erosive areas.

32 Horizontal relocation of roads may be a feasible option in areas of the watersheds where fields are
 33 unused and lay dormant. By relocating the roadway, more gradual grades can be obtained if the
 34 length of the road is increased through steep sections.

35 Roads should minimize disturbance of drainage patterns and be located where they do not
 36 introduce new water management problems (NRCS 2012). Buffers should be incorporated where
 37 possible to reduce sediment conveyance into the natural stream channels running throughout the
 38 watersheds.

1 **Removal/Vegetation of Unused Access Roads**

2 For access roads that currently receive little or no use, removal and revegetation of the roads is
3 recommended to reduce sediment generation to the greatest extent possible. The extensive road
4 network running along both sides of the fallow pineapple and sugarcane fields throughout the
5 Agricultural Management Unit is now largely unused, and revegetating many of these roads should
6 be considered. However, it is recognized that roads may function as fire fuel breaks and if unused
7 roads are needed as fuel breaks, practices to control runoff and erosion should be installed. The
8 extensive road network surrounding each of the fields within the watersheds provides many
9 alternate routes in place of the gridlike patterns that currently exist.

10 **Design Considerations**

11 Design considerations include:

- 12 • Intensity of visible erosion in the form of rills, gullies, and channels
 - 13 • Proximity of erosion to drainageways, including natural and manmade
 - 14 • Access road inventory assessment to determine which practice(s) applies to individual road
 - 15 segments based on current use, state of disrepair, etc.
- 16

B.5. Sediment Retention Basin

Description

One of the objectives for the environment of West Maui is the installation of sediment retention basins that trap sediments near their source to minimize downstream sedimentation and resulting degradation of nearshore and offshore water quality (Maui County Council 1996). Within Wahikuli and Honokōwai Watersheds, sediment retention basins will trap runoff from upslope fields, terraces, and access roads that currently contribute substantial sediment loads. Basins are constructed of earthen material, consisting of an embankment that functions to trap stormwater and promote ponding such that suspended sediment can settle out prior to discharge downstream through a regulated outlet or spillway. Outlet types include riprap channels, concrete outlet structures with orifices, or other stabilized features to prevent erosion at the structure outlet. Installation of retention basins at the outlets of water bars and broad based dips along roads are often considered micro-basins since they only catch water generated off relatively small areas. These micro basins require less time to design and install compared to larger retention basins that receive runoff from larger areas of land and thus hold more runoff and store larger volumes of sediment. Retention basins need to be cleaned periodically in order to maximize fine sediment trapping efficiency. The drawing below depicts a typical plan for a retention basin installed at the outlet of a water bar. The photograph depicts an actual large retention basin located in the Honokōwai Watershed that is sized to capture runoff and sediments from Honokao'ō Subwatershed within the larger Honokōwai Watershed.



Design Considerations

Identification of specific locations and preparation of design specifications for sediment retention basins recommended are beyond the scope of this WHWMP and will need to be done. The reader is referred to *Water and Sediment Control Basin* (NRCS 2008) for criteria relating to the successful design of agricultural basins in conformance with NRCS specifications. Proper siting will result in

1 frequent sediment collection near the sources and will have the added benefit of reducing volume
2 and travel length of flow, thereby decreasing potential for erosion.

3 ***Siting Guidelines***

4 Basins should be constructed in areas where natural or manmade drainage courses are located,
5 based on observed erosion actively occurring and where there appears to be adequate space
6 available for construction of a sediment basin. Locations proposed are considered to be some of the
7 most immediate in need of remediation, but should not be taken to be inclusive. In general,
8 construction of basins anywhere that runoff can be directed to them from erosive areas is a positive
9 step toward minimizing negative downstream effects. Basins should not be placed in areas adjacent
10 to buildings or other structures that may be affected in the event of flooding. Basins can be placed
11 alone or in series, if space permits, at a particular location. Sediment basins should not be located in
12 waters of the US as defined under the CWA.

13 ***General Construction Guidelines***

14 Sediment basins should be located in areas of active drainage flow, and be constructed in such a
15 way to intercept the flow with the embankment or berm and form a detention area. Dam slopes
16 should not exceed 2:1 horizontal to vertical (NRCS PIA 2011a). Basins must be sized based on
17 contributing drainage area, rainfall intensity, and other factors.

18 There are several sediment basins that were constructed during and subsequent to plantation
19 agriculture. Many of these basins may have placed in locations as the “catch all” management
20 practice. The sediment basins proposed in the WHWMP are recommended as an integral part of a
21 whole system to multiple management practices working together to achieve maximum reduction
22 of pollutant release to waterbodies within the watershed and the coastal environment.

23 ***Capacity and Sizing***

24 Sediment basins should be sized to handle the 10-year frequency, 24-hour duration storm event
25 through a combination of detention within the basin and flow through the stabilized outlet
26 structure (NRCS PIA 2011a). Basins are sized to impound runoff from design storms from small
27 areas of less than an acre up to several hundred acres. Basins should be designed with an
28 embankment 5% greater than the design height to accommodate settling of sediment and basins
29 must be sized to store at a minimum the 10-year sediment accumulation volume. Otherwise, a
30 sediment removal frequency plan must be in place to maintain the basin functionality. The basin
31 outlets should be stabilized so that discharge does not cause erosion problems at the outlet or
32 channelizing downstream.

33 ***Spacing***

34 Sediment retention basins should be placed frequently, similar to the spacing of other field drainage
35 practices (e.g. terraces). This will result in sediment collection close to the source of generation,
36 while minimizing uncontrolled erosion pathways. In many cases a retention basin can be located at
37 the outlet of a terrace or broad based dip/water bar. Basins placed on this “micro-scale” basis will
38 concentrate on prevention of erosion, rather than collecting sediment at the base of a field slope.
39 This will reduce sediment reaching the coastline. In contrast, the traditional method of placing a
40 large basin at the toe of field slopes results in longer erosive flowpaths. These flowpaths deliver

1 suspended sediment to the basin, which traps sediment further from its source of generation and in
2 closer proximity to the nearshore environment.

3 **Sediment Retention Basin (Micro)**

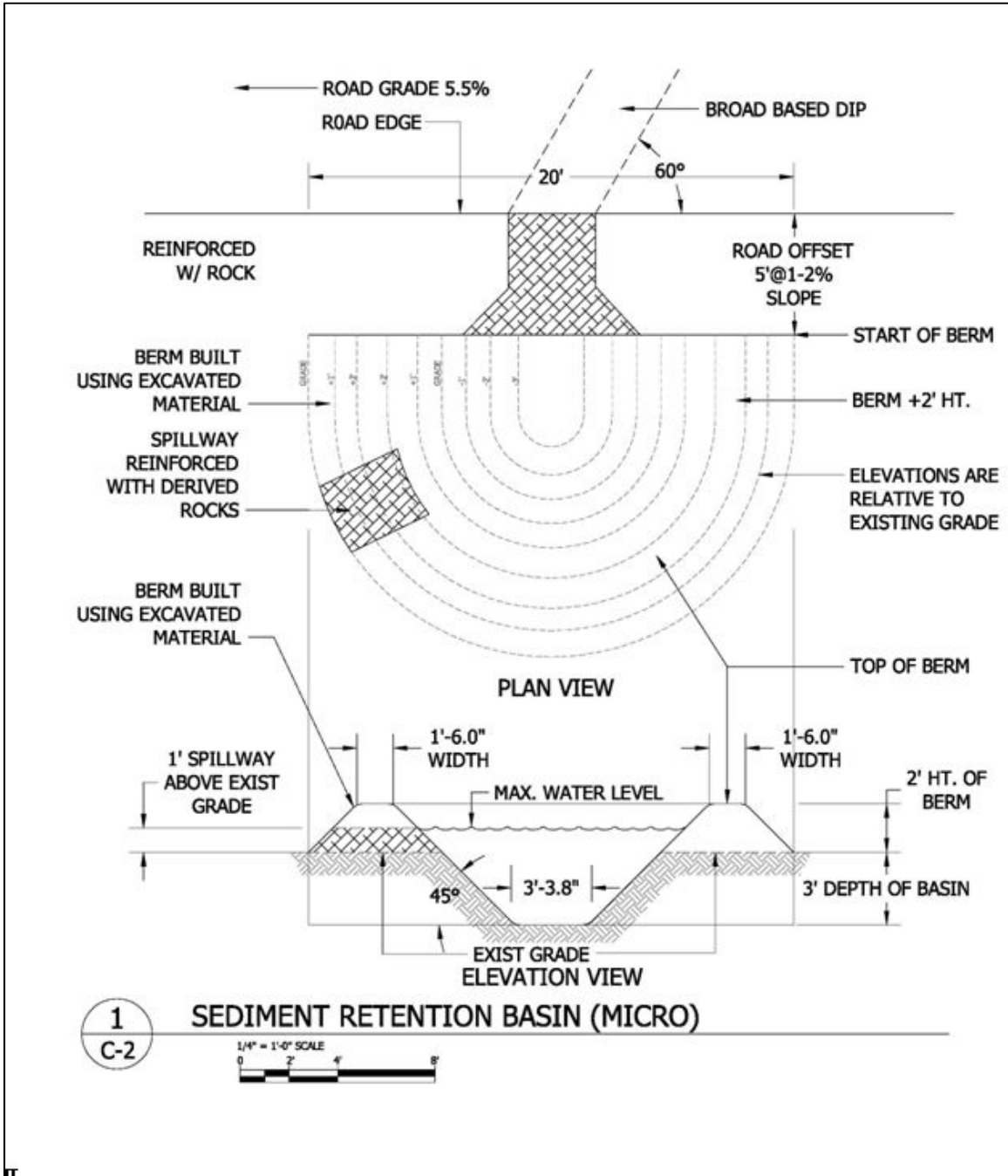

4
5

B.6. Vegetated Filter Strip

Description

A vegetated filter strip consists of herbaceous plantings within an evenly graded area that treat and infiltrate sheet flow stormwater runoff generated during rainfall events. Filter strips can also effectively treat irrigation water runoff. Filter strips capture and retain suspended sediments and other associated pollutants contained in the runoff, thereby reducing downstream transport. Strips typically contain healthy stands with stiff stems and high stem density that can withstand partial burial due to sediment accumulation within the area over time.

Design Considerations

- Filter strips must be constructed so that all flow entering them is under sheet flow conditions, to avoid creating ruts, gullies, or channels due to concentrated flow of runoff.
- The minimum width of the filter strip (minimum downslope length of flow through the strip) is 30 feet.
- The strip should be located immediately downstream from the source of sediment/pollution.

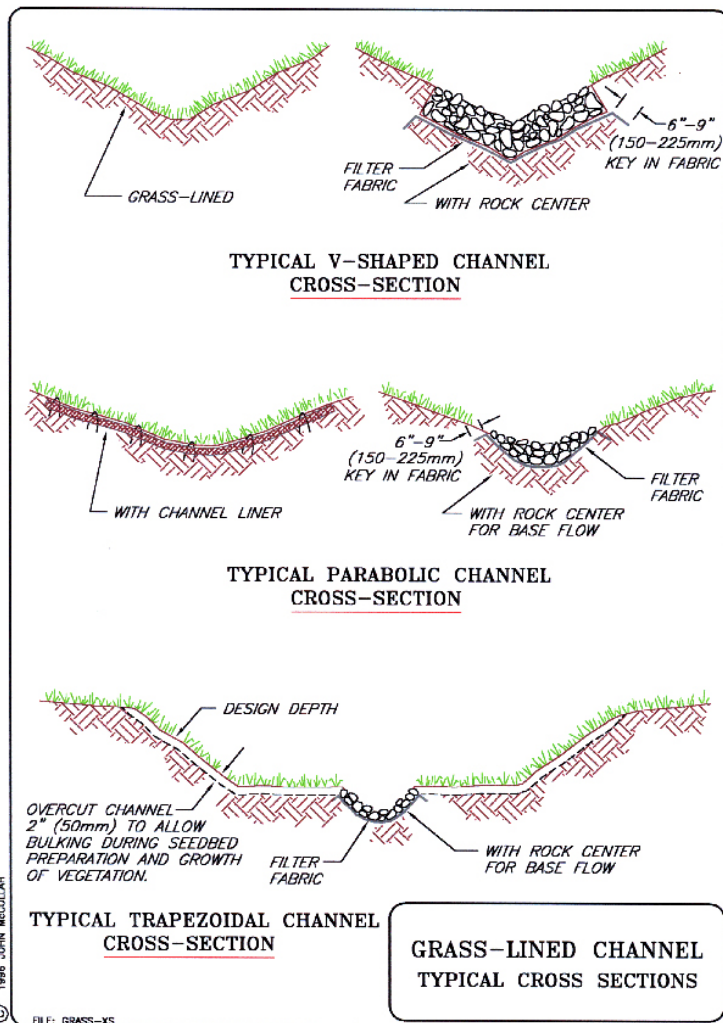

1 **Appendix C. Secondary Management Practices**

2 Secondary management practices are recommended for implementation after the priority
3 practices, when funding and resources are available. These secondary practices will result in
4 supplemental prevention and treatment of NPS pollutants, and result in additional reductions of
5 pollutant loadings to the coral reef environment. Details on the secondary management practices
6 include a description of the practice and a general description of where the practice should be
7 located.

8

1 **C.1. Curb Inlet Basket (with Filter)**

2 **Description**

3 Mesh curb/grate inlet baskets trap gross solids and are ideal for removing large quantities of
 4 hydrocarbons, including oils and grease when fitted with an optional absorbent polymer. Bio Clean
 5 has tested their curb inlet basket system in Hawai'i and reports having the lowest installation time
 6 and highest rated catch basin insert for performance and maintenance (Bio Clean 2009).

7 **Practice Locations**

8 There are many S4 inlets within the Urban Unit, a portion of which are targeted for curb basket
 9 retrofits due to their proximity to areas that receive high traffic volume (i.e. commercial parking
 10 lots, resort drop-off zones) and adjacent to areas where vehicles stop frequently (i.e. stoplights
 11 along Honoapi'ilani Highway). Curb basket retrofits are applicable to installation on private or
 12 State-owned inlets, given that there are no County of Maui maintained inlets within the project area
 13 (E. Kukahiko, pers. comm.). Recommended curb inlet basket locations are shown on Figures 3 and
 14 4. Curb inlet baskets are not recommended for installation on S4 systems where baffle boxes are
 15 installed, due to treatment redundancy (Appendix B.1). A general recommendation is to place inlet
 16 baskets on the most heavily used streets, near parking lots, and near areas where trash
 17 accumulates.

18 **Resources**

19 Bio Clean Environmental Services, Inc
 20 <http://www.biocleanenvironmental.com/>

21

Curb Inlet Basket with Shelf System

**CALIFORNIA CURB SHELF BASKET WATER CLEANSING SYSTEM
SAN DIEGO REGIONAL STANDARD CURB INLET**

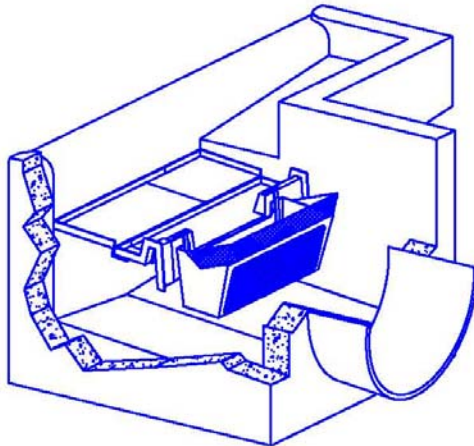

FIGURE 1
DETAIL OF PARTS

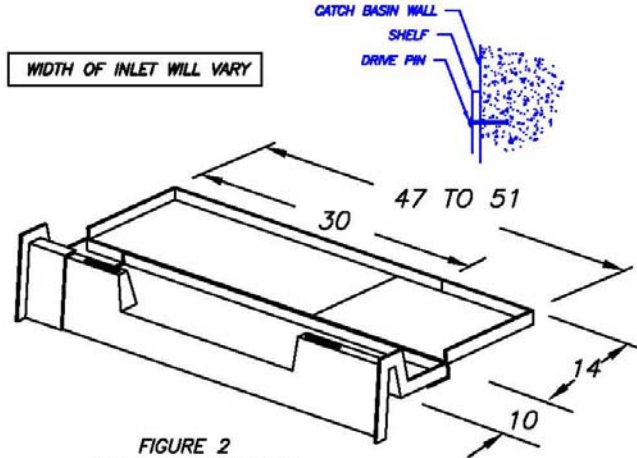

FIGURE 2
DETAIL OF INSTALLATION

REMOVABLE BASKET CATCHES EVERYTHING AND MAY BE REMOVED THROUGH MANHOLE WITHOUT ENTRY.

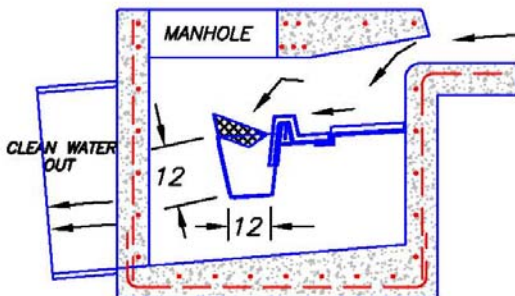

FIGURE 3
DETAIL OF PROCESS

FLOW RATES per 3 FT. Basket				
$Q=50 \cdot c_d \cdot A \sqrt{2 \cdot g \cdot h}$ $c_d = \frac{Q_{actual}}{Q_{theoretical}} = .67$				
	SO	A (ft ²)	h (ft)	Q (ft ³ /s)
Coarse Screen	.62	.84	0.146	1.06
Med Screen	.56	1.36	0.75	3.53
Fine Screen	.68	1.02	1.167	4.01
TOTAL				8.6

The above flow rates are based on unobstructed screens.

NOTES:

- 1.SHELF SYSTEM PROVIDES FOR ENTIRE COVERAGE OF INLET OPENING SO TO DIVERT ALL FLOW TO BASKET.
- 2.SHELF SYSTEM MANUFACTURED FROM MARINE GRADE FIBERGLASS,GEL COATED FOR UV PROTECTION.
- 3.SHELF SYSTEM ATTACHED TO THE CATCH BASIN WITH NON-CORROSIVE HARDWARE.
- 4.FILTRATION BASKET STRUCTURE MANUFACTURED OF MARINE GRADE FIBERGLASS,GEL COATED FOR UV PROTECTION.
- 5.FILTRATION BASKET FINE SCREEN AND COARSE CONTAINMENT SCREEN MANUFACTURED FROM STAINLESS STEEL.
- 6.FILTRATION BASKET HOLDS BOOM OF ABSORBENT MEDIA TO CAPTURE HYDROCARBONS. BOOM IS EASILY REPLACED WITHOUT REMOVING MOUNTING HARDWARE.
- 7.FILTRATION BASKET LOCATION IS DIRECTLY UNDER MANHOLE FOR EASY MAINTENANCE.

BOX MANUFACTURED FROM MARINE GRADE FIBERGLASS & GEL COATED FOR UV PROTECTION

5 YEAR MANUFACTURERS WARRANTY

PATENTED

ALL FILTER SCREENS ARE STAINLESS STEEL

EXCLUSIVE CALIFORNIA DISTRIBUTOR:
BIO CLEAN ENVIRONMENTAL SERVICE
TEL: 760-433-7640 FAX:760-433-3178
Email: info@biocleanenvironmental.net

SUNTREE QUALITY PRODUCTS ARE BUILT FOR EASY CLEANING AND ARE DESIGNED TO BE PERMANENT INFRASTRUCTURE AND SHOULD LAST FOR DECADES.

CURB INLET BASKET SYSTEM		PROJECT:	
		REVISION:	DATE:
DATE: 04/12/04	SCALE: SF = 15	REVISION:	DATE:
DRAFTER: N.R.B.	UNITS = INCHES	REVISION:	DATE:

1 C.2. Debris Removal

2 Description

3 Debris removal includes the removal and proper disposal of miscellaneous metals, car parts,
4 barrels, and other materials illicitly dumped in various locations. Removal of this material should
5 be completed by hand and/or machine efforts. The prohibition of dumping of heavy metals, oil, and
6 untreated sewage on land and water bodies, as well as safe and accessible disposal of hazardous
7 materials are objectives for a clean and healthy West Maui environment (Maui County Council
8 1996).

9 Illicit dumps with a variety of refuse materials were observed at several locations in gulches
10 draining Wahikuli Watershed, and it is likely that there are additional locations that were not found
11 during field observations. The observed locations are in somewhat isolated areas out view of the
12 general public.

13 The area along Lower Honoapi'ilani Road was inspected as part of the field work. The 22 storm
14 inlet vaults were visually inspected to have sediment and particulate matter including asphalt rock,
15 cigarette butts, vegetative litter, and coarse rubbish. While the Maui County Highway Department
16 conducts street sweeping, increased intervals of cleaning are recommended along this stretch of
17 road within the project area to minimize pollution draining into the storm sewer from the roadway.

18 Removal of this debris can be completed through a combination of hand and machine efforts, as
19 several of the dumping locations are at stream or culvert crossings on steep slopes above the
20 gullies. Steep sideslopes may make access to dumping areas difficult. Removal of the debris is
21 recommended due to the unknown quantity or nature of the contents of several of the barrels
22 found at the dump sites, as well as the contributions to pollutant runoff that the items are having
23 due to their composition and decay.

24 Practice Locations

25 Debris removal is recommended at the illicit dumps discovered in Wahikuli Watershed. One illicit
26 dump site in is Wahikuli Gulch, and another in an unnamed tributary to it at the roadway crossings
27 adjacent to the residential subdivision undergoing development *mauka* of Kā'anapali Golf Course.
28 Observed refuse includes miscellaneous metals, car parts, and barrels. The contents of the barrels
29 are unknown.

30 Increased County of Maui debris removal interval from catch basins is recommended, based on the
31 close proximity of the system to the coastline and ease of pollutant transmission to the coastal
32 environment.

33

1 C.3. Erosion Control Blanket / Turf Reinforcement Mat

2 Description

3 Turf reinforcement mats are made of synthetic fabric and are used to line bare soil areas both
 4 within the landscape and within channels to protect the channel bed and bank from erosion due to
 5 natural wasting of the banks and drainage flow through the channel. They allow a long-term
 6 solution for erosion control. Turf reinforcement mats maintain intimate contact with the subgrade,
 7 resulting in rapid seedling emergence and minimal soil loss. They allow water to infiltrate in
 8 substrate and provide for hydraulic connectivity to groundwater. Mats should be made of non-
 9 degradable fabric to ensure long-term protection of ground soils.

10 Stream bank stabilization is defined as the stabilization of an eroding stream bank using practices
 11 that consist primarily of ‘hard’ engineering such as, but not limited to, turf reinforcement matting,
 12 concrete lining, rip-rap or other rock, and gabions. The use of ‘hard’ engineering techniques is not
 13 considered a restoration or enhancement strategy but may be necessary in certain location where
 14 erosion threatens adjacent properties and the probability of success using soft engineering
 15 practices is low. Other sections along the channel banks can be treated with bioengineering and soft
 16 engineering practices, which can be expected to reduce bank erosion, increase site aesthetics,
 17 enhance instream habitat, and be less costly compared to hardened structures.

18 Practice Locations

19 Specific locations where channel erosion was noted during field inventories along Wahikuli Gulch
 20 and other stream channels have been identified and described in *Volume 1: Watershed*
 21 *Characterization*. Prevention controls recommended for Wahikuli Gulch focus on rehabilitation,
 22 restoration and protection of the exposed banks using turf reinforcement mats. Creation of a
 23 remedial plan is recommended to specifically address the problematic eroded areas within
 24 Wahikuli Gulch and other drainages (detailed design is beyond the scope of this WHWMP; Section
 25 3.5).

26 Wahikuli Gulch does not presently have any type of basin or embankment structure installed within
 27 its reaches. The West Maui Community Plan calls for maintenance of existing development of
 28 stream channels, gulches and other areas, not expansion (Maui County Council 1996). Māhinahina,
 29 Honokōwai, Wahikuli, and several other project area streams are listed as major streams and
 30 gulches that are to be kept as open space. For these reasons, installation of a basin/dam
 31 embankment structure in Wahikuli Gulch is not recommended. This does not rule out the
 32 installation of structural controls or other solutions in project area streams that are not included on
 33 the list of streams to be preserved for open space, as long as their natural filter functions are
 34 preserved (Maui County Council 1996). Filter functions can be preserved through such controls as
 35 long as they are in agreement with accepted engineering protocols and rules as may be adopted by
 36 the County of Maui Department of Public Works and Waste Management. Controls may include
 37 practices such as desilting basins, flow velocity moderation, baffles, and infiltration systems.

38 Erosion control blankets are recommended as protection for all access road embankments at
 39 crossings of Wahikuli Gulch. Many of these embankment sideslopes are currently eroding into the

1 drainageway and resulting in transported sediment downstream. Additionally, mats should be
2 implemented in areas where bare soil is exposed along the shoulders of the three primary paved
3 access roads, and erosion is occurring at accelerating rates (Figure 1). These primary roads provide
4 the access to agriculture lands and residential properties on the mauka side of Honoapiʻilani
5 Highway. They are Kakaalaneo Drive, a farm access road; Puukoli Road, used to access residential
6 neighborhoods and agriculture fields; and Akahale Street, the access road to Kapalua-West Maui
7 Airport. Due to their alignment and relative steep slopes, sediments generated off the shoulders are
8 routed to the S4 storm drain inlets at or near their intersection with the highway.

9 Field access roads throughout the watersheds also have eroding shoulders, which was evident
10 during field inspections as well as during aerial photography analysis. For the purposes of this
11 WHWMP, the eroding shoulders of the steepest segments of access roads aligned with the
12 watershed contours are the priority locations for erosion control blanket installation (Figure 1).

13 Turf reinforcement mats are recommended within the natural stream channel section of Wahikuli
14 Gulch in locations that are showing severe erosion and mass wasting (Figure 1).

15 When eroding stream banks are protected using turf reinforcement mats, they can serve as a filter
16 for surface water runoff from upstream areas, or as a sink for nutrients, contaminants, or sediment
17 present as NPS pollution in surface waters. Treatment potential within the stream channel can be
18 enhanced with the use of vegetation as part of the remedial design. Use of native and/or endemic
19 plants in channel stabilization designs that do not impair flow conveyance can enhance habitat
20 structure and aesthetics, and phytoremediate NPS pollutants, especially elevated nutrient levels
21 (Unser 2009).

22 Prevention controls recommended for Wahikuli Gulch focus on rehabilitation, restoration and
23 protection of the exposed banks using a combination of soft and hard engineering practices.
24 Management measures are expected to reduce bank and stream bed erosion and facilitate
25 remediation of NPS pollutants conveyed in runoff. Designs should consider the need to implement
26 solutions that maintain channel flow conveyance for flood management and maintain a natural
27 channel, to the extent possible, to provide for ecosystem functions.

28 **Resources**

29 North American Green
30 <http://www.nagreen.com/>

C.4. Facility Stormwater Assessment

Description

There are several light industrial facilities, commercial sites, and maintenance yards within Wahikuli and Honokōwai Watersheds that have potential to generate pollutants from associated materials, activities, and processes. Rainfall and associated stormwater runoff has potential to pick up pollutants from these sites and discharge them directly into nearby waterbodies/drainageways or indirectly via S4. Runoff from these areas can contain a variety of pollutants (e.g. heavy metals and chemicals, trash, debris, and oil and grease). Material spills or losses in these areas can also accumulate and be washed away during a storm. Activities associated with the various sites that may contribute to stormwater pollution include, but are not limited to:

- Material storage and handling
- Vehicle fueling and maintenance
- Shipping and receiving
- Fertilizer storage
- Pesticide storage
- Accidental spills and leaks
- Legacy industrial pollutants
- Improper waste disposal
- Dust or particulate-generating surfaces
- Outdoor process activities

Facility assessments should consist of the following actions:

Conduct Assessment of Activities at Pollutant-Generating Facilities

Perform a detailed walk-through of each facility to identify industrial materials or material handling activities exposed to stormwater. Identify any stormwater controls already in place at the facility, the direction of stormwater flow through the facility, and the location of all stormwater outfalls. If possible, conduct walk-through during a rain event to observe stormwater flow.

The facility assessment should be conducted by person(s) with expertise in the processes taking place at the facility, as well as hydrology and management practices typically used to control stormwater runoff and erosion.

Elements of the assessment approach include:

1. *Identify Activities Exposed to Stormwater.* The assessor will walk through the facility, noting features identified on site maps and those encountered in the field not depicted on maps. At a minimum, a list of the industrial/commercial activities exposed to stormwater should be made. Their location should be identified on the site map.
2. *Inventory of Materials and Pollutants.* A list of materials will be acquired from facility operators. The condition of storage, handling, uses and disposal of materials will be documented.
3. *Areas with Spill or Leak Potential.* The assessors will document where existing and potential spills and leaks, and identify discharge locations that could be affected by such spills and leaks. They will also document all significant spills and leaks that occurred in the past.

- 1 4. *Documentation of Non-stormwater Discharges.* Non-stormwater discharges often come from
 2 potable water sources. They will be documented. Typically, non-stormwater discharge is
 3 prohibited from a facility unless allowed under a NPDES permit. However, there are
 4 allowable non-stormwater discharges (e.g. fire hydrant flushings, potable water,
 5 uncontaminated air conditioner condensate).

6 **Conduct Sampling**

7 Sampling includes visual as well as analytic sampling data at stormwater outfalls of the site. The
 8 purpose of evaluating sampling data is to identify any pollutants of concern, hotspots, or control
 9 measures that are not functioning correctly.

- 10 1. Analytic sampling data can include benchmark monitoring or effluent limitation guideline
 11 data and can be performed on an annual or biannual basis. Results from sampling data can
 12 be compared to EPA 2008 Multi-Sector General Permit Benchmark values. This can be
 13 recorded on forms such as the Discharge Monitoring Reports available for download from
 14 NPDES website.
 15 2. Visual monitoring can be conducted on a quarterly basis during a storm event that produces
 16 stormwater discharge at the outlet of the site. Results can also be recorded on Discharge
 17 Monitoring Report forms.
 18 3. Sampling protocols should be established and followed.

19 **Develop General Location and Site Maps**

20 Maps that depict the site should be developed. Maps will typically identify the location of
 21 agricultural and industrial activities, pollutant sources, control measures, and the direction of
 22 stormwater flow. This will aid in future assessments, sampling, and selection of stormwater control
 23 and pollution prevention measures for the site.

24 **Selecting Stormwater and Pollution Control Management Practices**

25 Structural or non-structural stormwater control management practices are used to prevent or
 26 reduce the discharge of pollutants in stormwater. Typically a combination of structural and non-
 27 structural management measures results in the most effective stormwater management program.

28 Structural control practices are natural or hard structures used to control stormwater discharges.
 29 Examples of structural practices that can be implemented at facilities can include but are not
 30 limited to:

- 31 • Vegetative swales
 32 • Bioretention cells
 33 • Retention basins
 34 • Containment wells
 35 • Collection receptacles for reuse of stormwater

36 Non-structural control practices focus on facility operations and procedures to prevent generation
 37 of pollutants in stormwater and/or the volume of stormwater runoff discharged. Examples of non-
 38 structural practices include:

- 1 • Minimizing exposure of potential contaminants to the environment through effective
- 2 storage and handling methods
- 3 • Employee trainings
- 4 • Posting of signs to raise staff awareness of pollution generating processes
- 5 • Preparation of spill response plan.

6 **Practice Locations**

7 Assessments should be conducted at facilities including light industrial (e.g. cement production
8 plant, sugar cane train maintenance yard and grounds), fleet car rental facilities, and maintenance
9 yards for agricultural and golfing land uses (e.g. Kā'anapali Golf Course maintenance sheds; KLMC
10 agricultural maintenance facility). These facilities and sites have not triggered the NPDES
11 requirements for industrial stormwater permits, and therefore have not been required to develop a
12 stormwater pollution prevention plan (SWPPP).

13

C.5. Good Housekeeping Practices

Description

Good housekeeping practices include actions and activities that reduce the generation of NPS pollutants and runoff. In the Agricultural Unit these include maintenance facility operations and other practices involving storage and usage of fertilizer, pesticides, and field production related chemicals. A spill control plan, storm water pollution prevention plan, and implementation of a good housekeeping program to reduce the potential for fluid spills and migration of pollutants offsite that are associated with agricultural infrastructure are recommended. Ongoing training for workers involved in all aspects of field production is encouraged.

Box C.1. Good Housekeeping Practices

- Know the property boundaries, and where storm water from the property goes.
- Use biodegradable and recyclable cleaners when possible.
- Carefully select and control inventory. Having fewer materials on hand simplifies operations, reduces inventory cost, more effectively uses available roofed storage space, and lessens the opportunities for spills or leaks.
- Use good material storage practices (avoid toxic materials to the extent possible, store containers of liquids in a way they are unlikely be knocked over, cover stockpiled materials, consider the best place to conduct specific activities.)
- Conduct property maintenance (clean up the site, but not by washing grit and grime into the storm drainage system).
- Eliminate improper discharges to storm drains - only rainwater should run off the site.
- Clean up spills of materials or from equipment now, not later.
- Practice waste management (pick up litter, sweep areas and dispose of sweepings in the garbage (unless they are hazardous and require special disposal)
- Use good waste storage practices (keep dumpsters and other containers closed; store containers under cover)
- Dispose of mop water to a sanitary sewer.
- Maintain equipment and vehicles regularly. Check for and fix leaks.
- Wash cars over grass patches, use phosphorus free soaps, use carwash that discharges to a sanitary sewer.
- Capture rainfall using rain barrels, placing downspouts on vegetated areas, install rain gardens.

Practice Locations

Good housekeeping practices are recommended at all agricultural maintenance yards within the Agricultural Unit. Good housekeeping practices within the Agricultural Unit generally apply to the infrastructure associated with cultivation, irrigation, and nutrient supply to the agricultural fields. This includes the vehicle and fluid storage facilities within the Agricultural Unit.

Good housekeeping practices within the Urban Unit are generally associated with the impervious areas of resort, residential, and commercial land uses. Activities in these areas affect the types and amounts of contaminants that are generated, which impacts pollutant concentrations mobilized in runoff. Stakeholders should be educated and encouraged to engage in good housekeeping practices. Implementation of a good housekeeping program to reduce the generation of by-products associated with normal human activities is recommended for residents, employees, and business owners in Wahikuli and Honokōwai Watersheds.

1 **Resources**

2 *NPS Outreach Toolbox*

3 <http://cfpub.epa.gov/npstbx/index.html>

4 City and County of Honolulu's Storm Water Management Program

5 <http://www.cleanwaterhonolulu.com/storm/>

6

1 **C.6. Gutter Downspout Disconnection**

2 **Description**

3 Existing gutter downspouts can be disconnected from residential, resort, and commercial buildings
 4 that tie into closed drainage systems or discharge onto pervious surfaces, and be directed to
 5 stabilized areas where infiltration into soils can take place.

6 Resorts, commercial businesses, and residential houses are typically fitted with downspout pipes
 7 that discharge storm water off the property and onto the adjacent sidewalk and/or street, or into
 8 the closed drainage system. This practice is likely being conducted to reduce ponding that occurs
 9 during rainfall events. The funneled runoff adds to the runoff generated from County of Maui owned
 10 and private impervious areas including streets, sidewalks, and buildings. The higher volume of
 11 runoff increases the frequency and efficiency by which NPS pollutants are carried to S4 inlets. Rain
 12 falling on resort, commercial, and residential lots is lost as source water for the landscaped areas
 13 and adds to the disruptions to the hydrologic regime.

14 Disconnection of gutter downspouts attenuates runoff and directing the outlets to areas that are
 15 stabilized and/or can accommodate temporary ponding functions to capture some contaminants
 16 generated off the roof areas, more closely mimics the natural hydrologic regime. Individually,
 17 capture of rainwater at the individual house level will not significantly reduce runoff volume
 18 reaching the S4, nor will it increase the time of peak flows. However when adopted on a mass scale
 19 across the Urban Unit, benefits derived in terms of reduced water costs and increased awareness
 20 are real. Programs to disconnect downspouts should be scaled up across watersheds in order to
 21 increase the number of homeowners that participate and the volume of water captured, and
 22 correspondingly decrease runoff.

23 **Practice Locations**

24 Disconnection of downspouts is recommended for all resorts and hotels in the immediate vicinity of
 25 the coastline that are directly connected into the S4.

26



1 C.7. Irrigation Water Management Plan

2 Description

3 Comprehensive plan kept onsite at resort, golf course, industrial, and commercial facilities that
 4 generate nutrient and/or pesticide loadings applied through irrigation water use during the normal
 5 course of operations that are detrimental to watershed health. A plan should be created, if not
 6 already in place, and reviewed on a regular basis for efficiency and incorporation of changes in
 7 practices.

8 Plans produced for resort, hotel, business, and other professionally maintained lands within the
 9 Urban Unit should include at a minimum:

- 10 • Maps depicting total parcel acreage, landscaping and turf/grass locations, existing soils, and
 11 any waterbodies onsite.
- 12 • A summary of onsite soil conditions and water resources available to the site. This summary
 13 should include:
 - 14 ▪ Soil and/or plant tissue testing.
 - 15 ▪ Nutrient analysis of reclaimed R-1 effluent applied (as applicable to specific properties
 16 that utilize it).
 - 17 ▪ Irrigation water nutrient inputs (if R-1 effluent not used).
 - 18 ▪ Other significant sources of water.
 - 19 ▪ Current fertilizer application rates and historical usage.
- 20 • An inventory of hazards or concerns to incorporate into an evaluation of site limitations.
 21 Topics covered in this evaluation should include:
 - 22 ▪ Lava tubes.
 - 23 ▪ Shallow soils over fractured bedrock.
 - 24 ▪ Soils with high potential for leaching or runoff of irrigation water.
 - 25 ▪ Linear distance to surface water bodies.
 - 26 ▪ Soils with high erodibility.
 - 27 ▪ Shallow aquifers.
- 28 • The best available information for creating recommendations for turf and landscaping
 29 irrigation requirements.
- 30 • Identification of effective application methods and timing rates for irrigation. This should
 31 include:
 - 32 ▪ Irrigation rates necessary for establishment of healthy vegetative lawns and
 33 landscaping.
 - 34 ▪ A reduction in losses due to over-saturation of the soils to the environment.
 - 35 ▪ Avoidance of nutrient application during leaching and runoff periods.
- 36 • Soil erosion / sediment loss prevention practices.
- 37 • Proper calibration and operation provisions for the equipment used.

1 **Practice Locations**

2 Irrigation water management plans are recommended for both the Agricultural and Urban
3 Management Units. Within the Agricultural Unit, this practice applies to the active fields. Within the
4 Urban Unit, an irrigation water management plan should be produced for all resorts, hotels,
5 condominiums, businesses, and golf courses that use irrigation. Priority for implementation of
6 irrigation water management plans goes to: fallow seed corn fields closest to natural drainages or
7 access roads and resorts that do not currently have a plan in place.

8 **Resources**

9 Resources that can assist with developing a plan include:

10 http://www.nrcs.usda.gov/wps/portal/nrcs/detailfull/national/water/?cid=nrcs143_010855

11 ftp://ftp-fc.sc.egov.usda.gov/NY/eFOTG/section_1/cost_data/cpis/nycpis118.pdf

12 http://www.irrigation.org/Resources/Technical_Resources.aspx

13 <http://maine.gov/agriculture/mpd/irrigation/watermanageplantemplate.doc>

14 <http://www.ny.nrcs.usda.gov/technical/practices/pc449.html>

15

C.8. Natural/Native/Drought Resistant Vegetation

Description

Natural, native, and drought resistant vegetative cover provides a permanent, stabilized surface for soils that are vulnerable to erosion. Vegetative practices will decrease the rate of overland flow and amount of erosion generated from exposed soil areas. The type of vegetation and feasibility of long-term survival of plantings depends on site conditions, including existing vegetative cover, soils, rainfall, and topography. Selection of vegetative species should be based on specific location within the project area where vegetative cover is proposed, rainfall, and associated runoff rates. Selecting drought resistant vegetation for low rainfall areas is critical in areas without irrigation.

Embankment and stabilization through vegetation will aid in the preservation of dam and basin structures by minimizing erosion and degradation of the embankment face and prolonging the life of the structure. Stabilization is recommended through either natural vegetation practices consisting of drought tolerant planted species or through installation of riprap with an underlying geotextile product for permanent protection to ensure that erosion will not develop due to water infiltration through the stabilizing medium (Appendix C.11).

Practice Locations

Vegetative cover provides a natural, soft practice for stabilizing soil surfaces that are currently exposed and have high erosion potential, and is best implemented with erosion control mats. This practice remediates these areas and protects the ground surface from rainfall and overland flow. It also provides a micro-habitat for plant growth. Biodegradable erosion control blankets (Appendix C.3) provide ground cover on exposed areas, decrease slope length, and trap sediments. Covering exposed areas with an erosion blanket and seeding with species such as dry land *pili* (*Heteropogon contortus*), the drought tolerant *a'ali'i* (*Dodonaea viscosa*), and *alahe'e* (*Psydrax odorata*) are practices that have been successfully implemented during restoration efforts on Kaho'olawe.

Permanent vegetative cover is recommended for all exposed areas that are not planned for immediate stabilization, turf establishment, or pavement coverage:

- Along the embankment and shoulder areas of Honoapi'ilani Highway that are currently undergoing erosion action and generating sediment, crushed concrete, and asphalt particulates.
- Locations specified for erosion control blanket installation for the bare shoulders of the paved and unpaved access roads.
- All unvegetated pineapple terraces within Honokōwai Watershed.
- All areas of historic residential, commercial, or other construction within Wahikuli Watershed that were not stabilized prior to completion of site activities.

Honokōwai Structure #8 and Sediment Basin Embankments

Practice Description: Establish vegetative cover on inside and outside of Honokōwai Structure #8 dam embankment and proposed sediment basin embankments within the Agricultural Unit, to reduce the generation of sediment from the embankment itself. Stabilization will also help preserve the structure face and prolong the life of management practice. Stabilization is recommended

1 through either natural vegetation consisting of drought tolerant species, or riprap with underlying
 2 geotextile to ensure that erosion will not develop due to water infiltration through the stabilizing
 3 medium.

4 **Bare Soil Areas**

5 *Practice Description:* Stabilization of existing exposed bare soil areas through seeding and planting of
 6 grasses and/or drought-tolerant vegetation to reduce the quantity of sediment generated and
 7 transported downstream. Extended hotspots include shoulders of the unpaved access roads and
 8 paved roads within the Agricultural District, as well as other spot locations throughout the
 9 management units due to localized and historic erosion, construction, or other impacts.

10 **Terraces**

11 *Practice Description:* Establish vegetative cover on existing pineapple field terraces to reduce
 12 stormwater velocity from contributing access road runoff and promote settling of sediment.
 13 Periodically remove accumulated sediment that may be blocking runoff from entering terraces
 14 from adjacent access roads.

15 *Existing Terrace Maintenance:* Maintain terraces clear and in proper functioning condition for
 16 conveyance of runoff prior to discharge to stabilized areas or sediment basins. Foster vegetative
 17 growth for natural filtration by keeping terraces free of debris and sediment.

18 *General Construction Guidelines:* Terraces should be designed to control the runoff from a 10-year,
 19 24-hour storm event without overflowing (NRCS PIA 2011b). If sediment accumulation is hindering
 20 the function of terraces, verify that they are properly sized to contain the 10-year sediment
 21 accumulation load. Otherwise, establish a removal frequency plan for the sediment. Outlets should
 22 be vegetated so runoff is directed to a stabilized surface. The capacity of the outlet must be great
 23 enough so damage is not caused downstream.

24 *Resistance to Erosion:* The maximum permissible velocity for clay textural soils is 2.5 ft/s for
 25 erosion resistance.

26 **Sideslopes of Roads at Stream Crossings**

27 *Practice Description:* Establish sufficient stabilization via either vegetative cover or permanent rock
 28 stabilization with geotextile on existing and future road crossings at perennial and ephemeral
 29 stream locations.

30 *General Construction Guidelines:* Slopes should be permanently stabilized to counteract the varying
 31 climate conditions throughout the project area. Consider either drought resistance plants or riprap
 32 with underlain geotextile for permanent stabilization. Make the side slopes of cuts or fills in soil
 33 materials no steeper than 2 horizontal to 1 vertical (2:1) (NRCS PIA 2012).

34

1 **C.9. Pesticide Management Plan**

2 **Description**

3 A pesticide management plan is a conservation practice recommended for preparation in areas
 4 where pesticides are actively applied, stored, and present the potential for introduction into the
 5 drainage system. This includes resort, golf course, agricultural, industrial, and commercial facilities
 6 that generate pesticide loadings during the normal course of operations that are detrimental to
 7 watershed health. A pesticide management plan can include an updated list of pesticides currently
 8 applied on the subject parcel, known effects to groundwater and surface water, application rates,
 9 and other pertinent site specific information that results in the most effective use of pesticides.

10 The NRCS should be contacted for information related to creating and maintaining an effective
 11 pesticide management plan.

12 **Practice Locations**

13 Creation of a pesticide management plan is recommended for all agricultural activities that involve
 14 application of pesticides. Any fields that are actively cultivated within the watersheds, as well as the
 15 storage areas for the pesticide supplies should be covered in the pesticide management plan.

16 Within urban areas, the creation of a pesticide management plan applies to all resorts, businesses,
 17 hotels, and other landscaped and turfed areas that incorporate the usage of pesticides into the
 18 maintenance of grounds.

19 **Resources**

20 Resources that can assist with developing a plan include:

21 <http://www.nrcs.usda.gov/wps/portal/nrcs/detailfull/national/landuse/crops/npm/?cid=stelprd>
 22 [b1044461](http://www.nrcs.usda.gov/wps/portal/nrcs/detailfull/national/landuse/crops/npm/?cid=stelprdb1044461)

23

C.10. Pond Sampling Plan

Description

A pond nutrient sampling plan is recommended for all golf course ponds within the project area to analyze presence of pollutants and their potential impacts. At a minimum this plan should include a schedule of monitoring, concentration of nutrients and constituents sampled, current fertilizer application rates utilized at the course, laboratory results of samples analyzed at a State certified laboratory taken at pond outlet points (if known) and representative points within pond near courses, and any other applicable information that may be relevant to the data and findings. This plan will allow a benchmark program to be established such that nutrient concentrations can be evaluated over an extended period of time. There are no current DOH efforts to monitor golf course ponds for nutrients or other constituents (W. Okubo, pers. comm.).

The two ponds on Kā'anapali Kai Golf Course receive surface water runoff from land in central portions of the Wahikuli Watershed and a portion of sediments and particulates carried in runoff and deposited in these ponds is likely sequestered and does not reach the ocean via the culvert outlet. The ponds also likely intercept groundwater containing dissolved nutrients and other pollutants draining the upslope aquifers. The volume and quality of groundwater intercepted by these ponds is unknown. In the mid 1990's the two ponds experienced a series of algae blooms that were hypothesized to be caused by fertilizers applied to the golf course. Remedial actions to rectify the issue included release of herbivorous fish to eat the algae and control its spread (W. Wiltse, pers. comm.).

C.11. Riprap

Description

Riprap is angular rock used for stabilizing steep soil slopes (on which a healthy stand of vegetation cannot be established to minimize development of soil erosion) or within concentrated channels that would otherwise be susceptible to erosion from rainfall and concentrated runoff. The size of the rock used is based on the expected shear stress induced by flowing water. Rocks are normally reinforced or held together with either rebar and mortar or placed in wire baskets (gabion). Non-reinforced riprap structures are usually anchored into the ground to increase their resistance to movement. A geotextile fabric is typically installed prior to riprap placement to prevent undermining of soils. Riprap is recommended for stabilization on:

- Exposed soil surfaces that cannot be covered with sufficient vegetative growth to abate the development of erosion.
- Steep slopes that by their nature prevent the growth of vegetative stands.
- Areas where there is insufficient rainfall to keep vegetative cover alive.
- Outlets of terraces where they discharge into natural stream channels at the intersection of border access roads.
- Broad based dips and water bars for stabilization of outlet flow.

When carrying storm water runoff, the drainage terraces within the pineapple fields tie directly into the natural drainage channels flowing thorough both of the watersheds. The outlets of some of these terraces are located at the top of steep slopes above the natural drainages. Most outlets do not have energy dissipaters and/or sediment detention basins, leading to localized instability and formation of rills and gullies. Additionally, sediment from the terraces is often carried in runoff into the natural drainage ways.

Installation of riprap or erosion matting along with small sediment detention basins will reduce erosive energy, slow formation of rill and gullies, and trap a portion of the sediment carried from the terraces.

Practice Locations

Riprap is recommended at all access road crossings over Wahikuli Gulch. It is recommended at the intersection of the pineapple terraces into Honokōwai and Māhinahina Streams. It is also recommended in conjunction with construction of the broad based dips and water bars.

This stabilization should be incorporated on a priority basis as follows. Terraces near the bottom of field sections that currently show evidence of receiving accumulated sediment draining down along access roads through ruts or rills should be the highest priority for implementation. Incorporation of stabilization measures is recommended at the intersection of the terraces and the point where they drain into the natural stream channel. Recommended medium priority locations are terraces upstream from this point, which may be affected by localized rutting within the access road network and subject to sediment laden stormwater flow in future storm events. Low priority status is recommended for terraces at the higher reaches of field regions where there are minimal upstream fields or access roads contributing sediment into terraces. Terraces located immediately

- 1 downstream from access roads running perpendicular to ground slope should also be considered
- 2 low priority as the access road likely conveys runoff along its length parallel to the terraces.

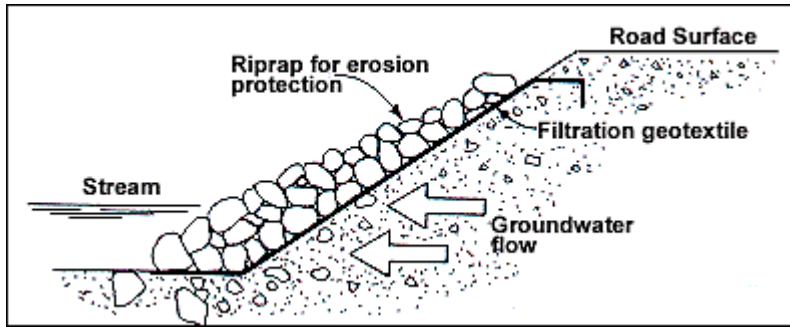

3



4

1 **C.12. Shoreline Erosion Control**

2 **Description**

3 Shorelines at beach parks and along other coastal properties are eroding and depositing sediment
 4 directly onto beaches and into the ocean. In many of these areas there are no defined access points
 5 or trails between the land and the beach zone, resulting in numerous areas that are trampled and
 6 without vegetation. The erosion results both from ocean wave run-up during moderate and large
 7 swells, and from runoff that flows off the land and over the shoreline towards the ocean. The
 8 sediments of concern are terrigenous, and not necessarily the beach sands, which in many areas are
 9 eroding and decreasing beach area.

10 “Soft engineered” designs that include bioengineering strategies utilizing native coastal plants in
 11 association with erosion control products such as erosion mats and coir logs are proposed to
 12 control erosion. These features will protect the terrestrial soils from erosion and not alter the
 13 nearshore ocean hydraulics, as happens with many hardened structures. The designs should
 14 include defining ingress and egress paths between the land and the ocean when necessary, as well
 15 as features to carry surface overland flow off the land into the ocean.

16 **Practice Locations**

17 Several shorelines were observed to be experiencing this type of erosion including:

- 18 - Wahikuli Wayside Beach Park(s)
- 19 - Honoka‘a Beach Park
- 20 - Beach front the Hyatt, Marriot and Westin Resort
- 21 - Honokōwai Beach Park
- 22 - Pōhaku Beach Park

C.13. Storm Sewer Disconnection

Description

Storm sewer disconnection involves the removal of strategic sections of existing closed piping networks that transport stormwater through the watershed. Removing sections of the system, and alternatively outletting runoff to open vegetated areas will promote natural system processes. These processes include promoting settling of sediment within runoff, extending the timing of runoff to more closely mimic pre-development conditions, and removal and retention of debris from transport into the nearshore zone.

Disconnecting storm sewer connections is a joint practice that is coordinated with bioretention cell construction, vegetated swales, or other LID practices to reduce the closed drainage system service area. Disconnection can be done at any resort area that has catch basins installed that direct runoff away from the site in lieu of concentrating runoff into depressed areas for treatment. All resorts with landscaped areas can utilize the potential for storm sewer disconnection, and implement low impact design practices as well.

The transition from disconnected stormwater piping outlets to new landscaped, bioretention treatment areas can potentially be softened through the use of native vegetative plantings. This can be accomplished by lining the outlet of the pipe outlet with plantings, as well as the zone between the pipe outlet and bioretention area, resulting in an aesthetically pleasing and environmentally beneficial design.

Practice Locations

Disconnection of the storm sewer network is recommended for Urban Unit hotels and resorts in conjunction with establishing alternate stormwater treatment measures such as bioretention or vegetated swales.

1 C.14. Vegetated Swale

2 Description

3 A vegetated swale is a shallow excavation, constructed on a gradually sloped grade, lined with
 4 vegetation along a waterway. The vegetated conveyance channel slows flow, temporarily impounds
 5 a portion of flow, filters a portion of pollutants, settles out sediment, encourages infiltration into the
 6 underlying soils, and reduces the potential for erosion caused by runoff velocities within the
 7 channel. Vegetated swales can be implemented wherever there is runoff that needs to be conveyed
 8 to a natural drainage channel from a treatment device, or as a conveyance from a land use that has
 9 preventative treatment measures incorporated into its design. They can be especially effective
 10 when constructed at grades approaching level because they slow water to the maximum extent
 11 possible while still maintaining positive grade. Ponding may occur in swales, which will aid in
 12 additional settling and treatment of the runoff. Vegetated swales temporarily store runoff and
 13 remove fine sediments, are useful for controlling higher frequency flood events (generally less than
 14 the 2-year), and can be designed with a spillway outlet to handle large rainfall events.

15 The West Maui Community Plan recommends that drainage channels not be used for building sites
 16 but rather be incorporated into the environment for public open space (Maui County Council 1996).
 17 The incorporation of landscaped and unlined channels is urged because it provides opens space
 18 continuity, with landscaped and green belt drainage channels favored over concrete-lined channels
 19 or culverts. Vegetated swales are recommended to reduce NPS pollutants and attenuate runoff
 20 generated off public and commercial parking areas and other impervious surfaces. They should be
 21 constructed along and adjacent to parking lots where there is room and non-impervious surfaces. ‘

22 Due to the arid nature of the Agricultural Unit, it is important that the vegetation within the
 23 vegetated swale can be maintained sufficiently to prevent spots of bare soil from developing. The
 24 hardlined ditches along Honoapi‘ilani Highway are recommended to be transitioned to vegetated
 25 swales in sections where runoff velocities from the concentrated flows will be below the rates for
 26 erosion generation. A drainage study to identify the effects of revising the channel lining on runoff
 27 generation and flow rates would most likely need to be undertaken by the County of Maui before
 28 implementing these changes and is outside of the scope of this report.

29 Practice Locations

30 Vegetated swales are recommended as an alternative to bioretention cells in areas where
 31 vegetation will not be naturally maintained, or will be damaged by pedestrian or vehicular use.
 32 Vegetated swales are recommended for placement adjacent to pollution-generating impervious
 33 surfaces, particularly in high traffic volume areas within the Urban Unit. Ideally, areas that receive
 34 low sediment loads should be selected and can include public beach parks, resort parking lots,
 35 resort drop-off points, and along paved roads.

36 Within resort properties, along the edge of parking lot pavement, or within parking lot islands
 37 between stalls and aisles are excellent locations for vegetated swales. The Sheraton Resort parking
 38 lot, located between the tennis courts and Kā‘anapali Parkway just past the cul-de-sac, and the
 39 Westin Resort parking lot, located between the Westin Resort and Kā‘anapali Parkway, may be
 40 locations that are well suited. Along Kā‘anapali Parkway in level areas adjacent to the edge of

1 pavement, where stormwater can sheet flow off the traveled way and into the swale is also
 2 recommended.

3 The five beach parks along the coast of the two watersheds may be excellent locations for vegetated
 4 swale installation. They all have parking lots adjacent to the public access area. While a detailed
 5 survey has not been performed at any of the sites, preliminary visual observations indicate there is
 6 potential for installation of vegetated swales adjacent to the parking lots, on the downslope side.
 7 This will need to be determined on a case-by-case basis once final design is completed.

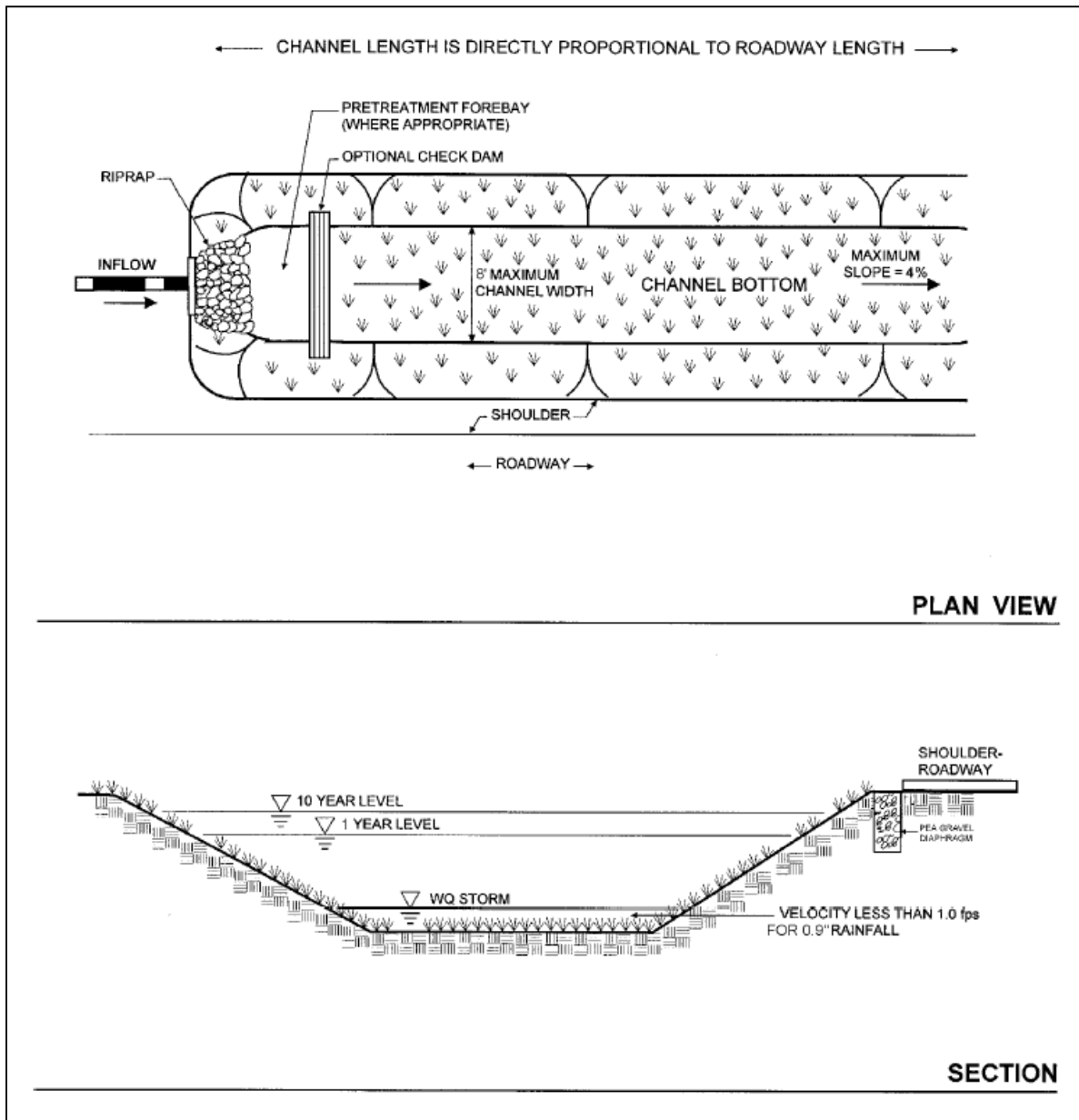

8

9

10

Note: Graphical representation only; not actual design.
 (from Vermont Stormwater Treatment Manual, http://www.vtwaterquality.org/cfm/ref/ref_stormwater.cfm)

1 **C.15. Other Secondary Management Practices**

2 **Vehicle Washwater Containment**

3 A vehicle washwater containment system is recommended at fleet vehicle maintenance facility
4 locations where active washing is occurring on a daily basis. These include several rental car
5 facilities along Honoapi'ilani Highway where spent washwater drains naturally into adjacent
6 channels and waterways. Since the majority of rental car locations are concentrated near the Dollar
7 Rental Car facility, and in close proximity to natural drainage courses, it is presumed that washing
8 occurs at all of these companies, including Dollar, Alamo, and Avis.



9

10 **Illicit Dumping Signage**

11 Signage prohibiting dumping is recommended at all known illicit dump sites within Wahikuli and
12 Honokōwai Watersheds. This includes the dump site noted at Wahikuli Gulch, and another in an
13 unnamed tributary to Wahikuli Gulch, at the roadway crossings adjacent to the residential
14 subdivision undergoing development *mauka* of Kā'anapali Golf Course. Stakeholder coordination is
15 recommended for determination of additional historic dumping locations, which may be secluded
16 in nature and not under active observation by either landowners or law enforcement officials.

17

1 This page intentionally left blank

1 Appendix D. Designing a Monitoring Program

2 D.1. Data Management, Evaluation, and Reporting

3 Quality Assurance and Quality Control

4 An integral part of any monitoring program is quality assurance and quality control (QA/QC).²³
 5 Development of a quality assurance project plan (QAPP) is the first step in incorporating QA/QC
 6 into monitoring (EPA 2002). The QAPP is a critical document for the data collection effort as it
 7 integrates the technical and quality aspects of the planning, implementation, and assessment
 8 phases of the project. The QAPP documents how QA/QC elements will be implemented during
 9 sample collection, data management, and data analysis. It contains statements about the
 10 expectations and requirements of those for whom the data is being collected and provides details
 11 on project-specific data collection and data management procedures designed to ensure that these
 12 requirements are met. Many of the elements and aspects of a QA/QC program are similar across
 13 program types, and the elements listed below are general in nature. The implementation of each
 14 management practice that will involve the collection and analysis of environmental data should be
 15 accompanied by the development of a QAPP.²⁴ EPA requires four types of elements in a QAPP that
 16 include (with some examples):

- 17 1. Project Objectives and Management
 - 18 - Project/task organization
 - 19 - Problem definition/background
 - 20 - Project/task description
 - 21 - Quality objectives and criteria for measurement data
 - 22 - Special training requirements/certification
- 23 2. Measurements and Acquisition
 - 24 - Sampling process design
 - 25 - Sampling handling and custody requirements
 - 26 - Analytical methods requirement
 - 27 - Quality control requirements
 - 28 - Instrument/equipment testing, inspection, maintenance requirements
 - 29 - Instrument calibration and frequency
- 30 3. Assessment/Oversight
 - 31 - Assessment and response action
 - 32 - Reports to management
- 33 4. Data Validity and Usability
 - 34 - Data review, validation, and verification requirements
 - 35 - Validation and verification methods
 - 36 - Reconciliation and user requirements

²³ A thorough discussion of QA/QC is provided in Chapter 5 of EPA's *Monitoring Guidance for Determining the Effectiveness of Nonpoint Source Controls* (EPA 1997).

²⁴ QAPP should be developed according to the guidance provided in *EPA Requirements for Quality Assurance Project Plans for Environmental Data Objectives* (EPA 1994). Additional information can be found at www.epa.gov/quality/qapps.html.

1 **Data Management**

2 A central data management system should be maintained by primary stakeholders with careful
 3 consideration for what level of quality control the data should be held to, where and how the data
 4 will be held, who will maintain the database, and how much will data management cost. Before
 5 initiating monitoring, it is important to establish data management procedures to enable efficient
 6 storage, retrieval, and transfer of monitoring data. These procedures should be identified in the
 7 QAPP with specifications related to a central filing system, field forms, electronic database,
 8 contractor instructions, and computer backup guidelines.²⁵

9 **Geographic Information Systems**

10 Geographic Information Systems are useful for characterizing the features of watersheds,
 11 documenting changes in land use, and maintaining data on management practice implementation.
 12 The spatial relationships among the locations of pollutant sources, land uses, water quality data,
 13 trends in land cover and development, installed management practices, and many other features
 14 can be represented graphically. Non-graphical data on characteristics of management practices (e.g.
 15 sizing of pipes and stormwater inlets, materials used in infrastructure, dates of inspections, and
 16 water quality results) can be incorporated into the GIS database and layer attribute tables.²⁶ A GIS
 17 database can be an extremely useful tool for management practice tracking and for detecting trends
 18 in implementation, land use changes, and virtually any data related to management practices and
 19 water quality. It is also valuable for communicating data to a wider audience. In order to guarantee
 20 data integrity and availability, as well as security, guidance for access and control should be laid out
 21 in the QAPP.

22 **Data Evaluation**

23 Evaluation of management practices includes statistically summarizing and analyzing collected
 24 data. Data analysis begins in the monitoring design phase and QAPP when the goals and objectives
 25 for monitoring and the methods to be used for analyzing the collected data are identified. Data
 26 analysis typically begins with screening and graphical methods, followed by evaluating statistical
 27 assumptions, computing summary statistics, and comparing groups of data. The development of a
 28 statistically relevant experimental design for data collection is strongly recommended and would
 29 benefit from consultation with a statistician during the design phase.²⁷

30 **Presentation of Monitoring Results**

31 Management practice monitoring results should be presented in a practical and comprehensible
 32 form. The target audience(s) (scientists, school groups, policy makers, etc.), format (written or

²⁵ The International Storm Water BMP Database uses a combination of data entry spreadsheets in Microsoft Excel and a master database in Microsoft Access (WWE and Geosyntec 2009). Both the spreadsheets and the master database can be downloaded from www.bmpdatabase.org.

²⁶ The attribute table of a GIS mapping layer is a relational database that is linked to a geographic feature and stores characteristics of that feature in tabular format.

²⁷ Statistical analysis and sampling designs are addressed in detail in Chapter 3 of EPA's report, *Techniques for Tracking, Evaluating, and Reporting the Implementation of Nonpoint Source Control Measures – Urban*, and data analysis and interpretation are addressed in detail in Chapter 4 of EPA's *Monitoring Guidance for Determining the Effectiveness of Nonpoint Source Controls* (EPA 1997; 2001).

oral), and style (graphics, table, etc.) are factors in the selecting the appropriate means for presentation. Presentation of results will be built around the information that was collected, the statistical findings, and the process of the data collection (i.e. experimental design). Technical quality and completeness of results will ensure adequate information for making management decisions related to evaluating the effectiveness of installed management practices.²⁸

D.2. Types of Monitoring

Measurable progress is critical to ensuring continued support of watershed management efforts, and progress is best demonstrated through monitoring data that accurately reflects improved water quality conditions relevant to the identified problems. Other applications of monitoring data include: analyzing long-term trends; documenting changes in management and pollutant source activities; measuring performance of specific management practices; calibrating or validating models; filling data gaps; tracking compliance; and providing information to educate stakeholders.

Monitoring includes quantitative and qualitative methods that can range from visual verification of a practice in the field to complex statistical approaches requiring experimental designs. Quantitative monitoring methods are used to quantify pollutant responses to installed management practices and could include sampling of water quality, measurements of solids sequestered, vegetation density, channel morphology, and hydrology. Qualitative approaches often utilize repeated visits to the location of a practice installation or reference area that the practice is designed to improve and taking photographs that show the practices in use or changes to the reference area over time. The level of effort for monitoring can vary significantly, and practical considerations such as availability of funds and the training and background of the persons conducting the monitoring need to be considered when designing the monitoring program. In many instances implementation monitoring is the minimum level of effort that can be performed. This level is often is all that is needed to ensure that some level of pollutant reduction is occurring by simply documenting the pollution control practices are installed.

There are seven types of monitoring used in watershed management (Box D.1) (EPA 1997). There can be considerable overlap and some redundancy between the types and there is no strict definition or standards that define them. This plan focuses on four types of monitoring: trend, implementation, baseline and effectiveness.

Box D.1. Types of Monitoring Used in Watershed Management

Trend monitoring. Use of the adjective “*trend*” implies that measurements will be made at regular, well-spaced time intervals in order to determine the long-term trend in a particular parameter. Typically the observations are not taken specifically to evaluate management practices (as in effectiveness monitoring), management activities (as in project monitoring), water quality models (as in validation monitoring), or water quality standards (as in compliance monitoring), although trend data may be utilized for one or all of these other purposes.

Baseline monitoring is used to characterize existing water quality and watershed conditions, and to establish a database for planning or future comparisons. The intent of baseline monitoring is to capture much of the temporal variability of the constituent(s) of interest, but there is no explicit end point at which continued baseline monitoring becomes trend or effectiveness monitoring.

Implementation monitoring assesses whether activities, actions or installation of practices were carried out as planned. The most common use of implementation monitoring is to determine whether management practices were

²⁸ Techniques and recommendations for quality presentations can be found in Chapter 6 of EPA’s report, *Techniques for Tracking, Evaluating, and Reporting the Implementation of Nonpoint Source Control Measures – Urban* (EPA 2001).

1 implemented as recommended. Typically, this is carried out as an administrative review and does not involve any water
 2 quality measurements. Many believe that implementation monitoring is the most cost-effective means to reduce NPS
 3 pollution because it provides immediate feedback to the managers on whether the practices installation are being carried
 4 out as intended.

5 **Effectiveness monitoring.** While implementation monitoring is used to assess whether a particular activity was carried
 6 out as planned, effectiveness monitoring is used to evaluate whether the specified practice activities had the desired
 7 effect. Confusion arises over whether effectiveness monitoring should be limited to evaluating individual practices or
 8 whether it also can be used to evaluate the total effect of an entire set of practices on water quality and watershed
 9 condition.

10 Monitoring the effectiveness of individual practices, such as the capture of fine sediments by a baffle box, is an important
 11 part of the overall process of controlling NPS pollution. However, in most cases the monitoring of individual practices is
 12 quite different from monitoring to determine whether the cumulative effect of all or portion of the practices result in
 13 reducing the generation and transport of NPS pollutant to receiving waters. Evaluating individual practices may require
 14 detailed and specialized measurements best made at the site of, or immediately adjacent to, the management practice.
 15 In contrast, monitoring the overall effectiveness of practices is usually done at reference locations along the stream
 16 channel or in the ocean. Thus, it may be difficult to relate the measurements at reference locations to the effectiveness
 17 of individual practices.

18 **Project monitoring** assesses the impact of a particular activity or project, such as good housekeeping practices.

19 **Validation monitoring** refers to the quantitative evaluation of a model that is used to estimate pollutant load reductions
 20 or achieve some other objective. The intensity and type of sampling for validation monitoring should be consistent with
 21 the output of the model being validated.

22 **Compliance monitoring** is used to determine whether specified water-quality criteria are being met. The criteria can be
 23 numerical or descriptive. Usually the regulations associated with individual criterion specify the location, frequency, and
 24 method of measurement.

25 Trend Monitoring

26 Use of the adjective “*trend*” implies that measurements will be made at regular, well-spaced time
 27 intervals in order to determine the long-term trend in a particular parameter. Typically the
 28 observations are not taken specifically to evaluate management practices (as in effectiveness
 29 monitoring), management activities (as in project monitoring), water quality models (as in
 30 validation monitoring), or water quality standards (as in compliance monitoring), although trend
 31 data may be utilized for one or all of these other purposes.

32 Implementation Monitoring

33 Implementation monitoring documents and records information about the installation of
 34 management practices including: which management practices are being implemented; where they
 35 were installed; when they were installed; the entity that installed them; and what pollutants they
 36 are targeting. An implementation monitoring program is a mechanism to track progress and
 37 provide verification that a recommended practice was installed successfully. Implementation
 38 monitoring is probably the most beneficial type of monitoring recommended in the WHWMP since
 39 the implementation of strategies to reduce land based pollutants and adverse impacts to the coral
 40 reefs is vital to achieve ecosystem restoration.

41 The normal sequence of events leading up to implementation monitoring is that a need for a
 42 practice to reduce NPS pollutant(s) and the entity responsible for its implementation are identified.
 43 The responsible entity then develops detailed engineering designs, generates a cost estimate to
 44 install the design and installs the design. In reality, this “normal” sequence often involves a
 45 considerable amount of time between the identification of the need and installation of the practice.
 46 The biggest reason for this lag time is the lack of funding to design and install the practice. An

1 implementation monitoring plan can be used to document and identify the phases of the process
 2 that result in delays to installation to help develop solutions to expedite the process.
 3 Implementation monitoring is described in detail in the EPA report *Techniques for Tracking,*
 4 *Evaluating, and Reporting the Implementation of Nonpoint Source Control Measures - Urban* (EPA
 5 2001). This type of monitoring aligns with NOAA Coral Program's LBSP Performance Measure 2
 6 **(Error! Reference source not found.)**.

7 **Baseline Monitoring**

8 Baseline and effectiveness monitoring are temporally linked by pre- and post-implementation of a
 9 practice. Baseline monitoring is the initial pre-project collection of data and information. It
 10 transitions to effectiveness monitoring following installation of a practice or beginning of an
 11 activity. Baseline monitoring documents existing water quality and watershed conditions and is
 12 used to compare changes to a parameter being sampled following implementation of a practice.
 13 Water quality baseline data is usually collected at representative locations such as confluence of
 14 channels, stormwater outfall locations and at the mouth of streams.

15 The main objectives of baseline monitoring are to document existing conditions in a watershed by:
 16 identifying locations where pollutants are generated; sampling water quality in surface runoff,
 17 streams and ocean waters; and mapping flow transport pathways of pollutants. This allows a
 18 characterization of the extent of NPS pollution problems in the watershed and its water bodies that
 19 can be used to determine the stressors to the aquatic system and assess changes (i.e. post-
 20 implementation of management practices). This can be used to tailor the management practice
 21 design and identify pollutants that are impairing water quality and to identify location to install
 22 practices. Before new data are collected, available historical data, as well as data currently being
 23 collected should be identified and consolidated and have their validity and usability assessed.²⁹
 24 Existing data can help in deciding what other data sets need to be collected, and how to expand the
 25 original data set by either continuing with existing protocols or developing new ones that can
 26 utilize the existing data. Pooling individual studies assists in identifying trends in environmental
 27 conditions and comparing effectiveness of implemented management practices.

28 Baseline measurements of pollutants in water bodies are often collected to assess the condition of
 29 water quality relative to water quality standards. Once a problem is identified, determining its
 30 spatial scale and geographical and temporal extent helps to focus management efforts. Determining
 31 the causes and sources of the impairments are often more difficult than determining its presence
 32 because there are often many potential sources with overlapping influences.

33 Controlling for influencing factors such as climate is necessary if baseline monitoring is to be used
 34 as a reference point for trend analysis and management decisions. The ability to relate water
 35 quality responses to land management depends on the quality and quantity of data collected prior
 36 to any changes of land management practices.

²⁹ Data validity implies that individual data points are considered accurate and precise with known field and laboratory methods. Data usability implies that a database demonstrates an overall temporal or spatial pattern.

1 **Effectiveness Monitoring**

2 **Definition and Purpose**

3 Effectiveness monitoring is used to determine whether management practices, as designed and
4 implemented, are functioning as planned and improving water quality. This type of monitoring is
5 essential for determining how effective the practices are once they are installed. The information
6 obtained from effectiveness monitoring can be used to adjust design of the practices, change the
7 types of practices if the installed practices are not effective, identify locations for future
8 installations, and document reductions of NPS pollutants. Effectiveness monitoring is the subject of
9 the EPA guidance document *Monitoring Guidance for Determining the Effectiveness of Nonpoint*
10 *Source Controls* (EPA 1997). This type of monitoring aligns with NOAA Coral Program's LBSP
11 Performance Measure 3 (**Error! Reference source not found.**).

12 Water quality monitoring is an integrated activity for evaluating the physical, chemical, and
13 biological character of water in relation to human health, ecological conditions, and designated
14 water uses (ITFM 1995). An important water quality monitoring element for NPS pollutants is
15 relating the physical, chemical, and biological characteristics of receiving waters to land use
16 characteristics. The most desirable scenario for conducting effectiveness monitoring is to have a
17 robust set of water quality baseline data to compare to the post-practice installation water quality.
18 This scenario will allow a statistical analysis on post-practice load reductions and water quality
19 improvement. When baseline data is unavailable the probability of computing load reductions is
20 low, making load monitoring difficult. Load monitoring requires considerable effort and should
21 follow protocols documented in *Urban Storm Water BMP Performance Monitoring: A Guidance*
22 *Manual for Meeting the National Storm Water BMP Database Requirements* (GeoSyntec and ASCE
23 2002).

24 **Sampling Locations**

25 Effectiveness monitoring is primarily conducted at the location where the pollutant control
26 management practice is installed and on areas along the flow pathway down gradient. Baseline data
27 collected prior to the installation of a practice will provide a reference condition for which to make
28 post installation comparisons against and compute NPS pollutant load reductions. Selection of
29 reference sampling sites that are representative of the flow network is an important step in the
30 monitoring system design. Effectiveness monitoring is the easiest and most accurate way to
31 evaluate if the practice is working as designed. Effectiveness monitoring can also be conducted at
32 representative locations on the water bodies or surface areas located down the flow gradient from
33 the installed practice. However, it is often difficult to correlate the changes measured at sites
34 located away from the practice installation due to unknown inputs and outputs that occur between
35 the installed and sampling sites. In addition, when multiple practices are installed, ascribing
36 changes to one practice becomes difficult and usually the reference sample value is representative
37 of the cumulative impacts derived from all the practices. For this reason some watershed scientists
38 divide monitoring into two categories based on the sampling location following installation of
39 management practices. Samples collected at the installation site are defined as effectiveness
40 monitoring and those collected at reference locations are classified as trend monitoring. In general
41 the monitoring output of these two monitoring types are positively correlated: if a practice is

1 effective (i.e. shown to be trapping fine sediment), then the trend in water quality at a down
2 gradient stream sampling reference site will likely show a decrease in turbidity.

3 **Methods**

4 Effectiveness monitoring can be carried out using quantitative and/or qualitative methods.
5 Qualitative methods are generally easy to conduct, less costly, and do not require significant
6 training to carry out compared to quantitative methods. Qualitative methods are however prone to
7 subjective analysis. Protocols should minimize opportunities for bias and subjectivity during
8 monitoring activities. When utilizing volunteers to conduct monitoring providing sufficient subject
9 matter background is recommended.

10 Quantitative methods range in complexity, level of effort to carry out, and cost. Selection of the
11 quantitative method should in part be based on the minimum level of effort needed to determine if
12 the installed practice is functioning effectively and meeting regulatory compliance requirements.
13 For example, it may be sufficient to measure the amount of sediment trapped in a baffle box
14 periodically to determine how much sediment was captured per unit time. This would allow
15 calculation of the amount of sediment removed from stormwater that entered the baffle box, and
16 would equate to a reduction of sediment delivered to the receiving waters. The baffle box would be
17 considered 'effective' since it captured sediment. A more involved monitoring scheme would be
18 needed to determine the efficiency of a baffle box and compute the load reduction for a storm event.
19 For example, measurements of flow into and out of the baffle box during a storm event would need
20 to be collected and the concentration of sediment in each measured. This sampling approach allows
21 computation of the efficiency of the baffle box and the pollutant load reduction. It requires more
22 equipment, labor, and total cost to implement compared to simply measuring the sediment in the
23 baffle box.

24 The reduction in pollutant concentration that a baffle box or other installed treatment device
25 provides can be quantified by sampling water entering and leaving the device and comparing the
26 change. The three commonly used measures are concentration grab samples, total contaminant
27 load conveyed over a specified duration (i.e. storm event), or event mean concentration. An
28 understanding of how the monitoring data will be analyzed and evaluated is essential to determine
29 the collection methods. Methods of estimating water quality concentration for various pollutants
30 require significant time, persons with technical skills and adequate funds. They are not
31 recommended as part of the effectiveness monitoring, but rather presented as specific examples of
32 rigorous numeric methods that could be conducted.

- 33 • Pollutant concentration measured at individual points in time can be useful in determining
34 concentration as a function of time or if the "first flush" phenomenon occurred during a
35 specific storm event. This type of monitoring is best when focusing on outflow monitoring.
- 36 • Contaminant loads are typically calculated by using an average concentration multiplied by
37 the total volume over the averaging period. Accurate flow measurement or modeling is
38 essential for load estimation. This method can be used to determine dry weather flows that
39 can contribute substantially to long-term loading.
- 40 • Event mean concentration is a method for characterizing pollutant concentrations in
41 receiving water from a runoff event. The value is determined by compositing (in proportion

1 to flow rate) a set of samples, taken at various points in time during a runoff event, into a
2 single sample for analysis. The primary aim is to analyze rain storm events at a site. It often
3 provides the most useful means to quantify the pollution level resulting from a runoff event.

4 In many instances the proper O&M of a management practice is as important as the proper design
5 and installation. Regular maintenance and inspection insures the practice is functioning at full
6 effectiveness. Deferred maintenance can adversely affect a practices' performance and can result in
7 pollutants bypassing or moving through the structure without reduction. Inspections can also
8 identify repair needs or retrofits, as well as areas that require additional management resources.
9 Effectiveness monitoring can be coordinated with routine maintenance schedules and if possible
10 personnel performing maintenance can be enlisted to conduct the effectiveness monitoring.

D.3. Effectiveness Monitoring Protocols

Table D.1. Effectiveness Monitoring for Priority Management Practices at Installation Locations³⁰

Practice	Monitoring Objective	Protocol	Target NPS Pollutants								Frequency
			Sediments	Nutrients	ODS	Pathogens	Metals	Hydrocarbons	Organics	Stormwater flow	
Priority											
Baffle Box	Qualitative/ Quantitative	Visual assessment; assessment of sediment volume; grab sample	X	X	X	X	X	X	X		Biennially or prior to vault cleanout
Bioretention Cell (Rain garden)	Qualitative/ Quantitative	Visual assessment; assessment of sediment volume		X		X	X	X		X	Annually; or after large volume/intensity storm event
Burn Area Emergency Rehabilitation Plan	Qualitative	Community Collaboration	X	X							Annually
Conservation Cover	Qualitative	Visual assessment of condition	X								Annually
Dam Debris Port Retrofit	Qualitative/ Quantitative	Visual assessment; assessment of sediment volume	X								Concurrent with routine or as needed maintenance
Fertilizer Management Plan	Qualitative/ Quantitative	In house Review; technical assessment of nutrient use									Annually; and when new personnel are responsible for application
Road Drainage Improvements	Qualitative	Visual assessment of condition	X								Annually; or concurrent with routine or as needed maintenance
Road Realignment and Rebuilding	Qualitative	Visual assessment of condition	X								Annually; or concurrent with routine or as needed maintenance
Sediment Retention Basin	Qualitative/ Quantitative	Visual assessment; assessment of sediment volume	X	X			X			X	After large volume/intensity storm event; minimum biennially
Vegetated Filter Strip	Qualitative	Visual assessment of condition	X								Annually
WWRF Alternate Disposal: Increase Production and Reuse of R-1 Water	Quantitative	Effluent sampling	X	X							As required by permit

³⁰ **Monitoring Objective:** Specifies whether analysis is quantitative or qualitative. **Protocol:** Identifies type of protocol to be used for sampling. **Target NPS Pollutants:** Identifies NPS pollutants being addressed by the management practice. **Frequency:** Recommended frequency of monitoring efforts.

1

Table D.2. Effectiveness Monitoring for Secondary Management Practices at Installation Locations

Practice	Monitoring Objective	Protocol	Target NPS Pollutants								Frequency
			Sediments	Nutrients	ODS	Pathogens	Metals	Hydrocarbons	Organics	Stormwater flow	
Secondary											
Curb Inlet Basket (with Filter)	Qualitative/ Quantitative	Debris type and volume	X	X	X	X	X	X	X		Concurrent with routine or as needed maintenance
Debris Removal	Qualitative/ Quantitative	Debris type and volume					X	X			Annually
Erosion Control Blanket / Turf Reinforcement Mat	Qualitative	Visual assessment		X							Biannually
Facility Stormwater Assessment	Qualitative	Review of operation; visual assessment	X	X	X		X	X		X	One-time
Good Housekeeping Practices	Qualitative	Survey		X	X				X		Annually
Gutter Downspout Disconnection	Qualitative	Visual assessment								X	Annually
Illicit Dumping Signage	Qualitative	Visual assessment					X	X			Annually
Irrigation Water Management Plan	Qualitative/ Quantitative	In house Review; technical assessment of water use	X	X							Annually; and when new personnel are responsible for application
Natural/Native/Drought Resistant Vegetation	Qualitative/ Quantitative	Vegetation survey	X	X		X					Annually
Pesticide Management Plan	Qualitative/ Quantitative	In house Review; technical assessment of pesticide use							X		Annually; and when new personnel are responsible for application
Pond Sampling Plan	Qualitative/ Quantitative	Visual assessment, sampling event		X							Annually
Riprap	Qualitative	Visual assessment of condition	X								Annually
Shoreline Erosion Control	Quantitative	Measure changes to position	X	X		X					Bi-annually
Storm Sewer Disconnection	Qualitative	Visual assessment								X	Annually
Vegetated Swale	Qualitative/ Quantitative	Visual assessment; assessment of sediment volume	X			X	X	X		X	Annually
Vehicle Washwater Containment	Qualitative	Visual assessment	X				X	X			Washing event

PRIMARY MANAGEMENT PRACTICES

Road Drainage Improvements

Monitoring Objective: Validate that storm water runoff is being directed into the broad based dip and not bypassing, or causing erosion or rills downstream from the stabilized outlet.

Protocol: (1) Assess the presence of rills and channels within the roadway grades leading to dips and water bars. (2) Assess dips for presence of rills or channelized runoff. (3) Verify the stabilized outlet is preventing scour from forming at point where stormwater is directed off of road. (4) Assess the presence of rills, channels, or sediment deposition downstream from the stabilized outlet. (5) Inspect intersection of terraces and access road for evidence of runoff bypass downhill due to sediment clogging of terrace.

Frequency: Annually, or concurrent with routine or as-needed maintenance.

Roads

Monitoring Objective: (1) Validate that road sections that have had realignment of grades and/or physical relocation are not creating new erosion pathways.

Protocol: (1) Assess the presence of rills and channels within the roadway grades of realigned / relocated sections. (2) Assess dips (if present) following the protocols listed for Broad Based Dips and Water Bars. (3) Assess the stability of the roadway by verifying presence of road surface undermining.

Frequency: Annually; or concurrent with routine or as-needed maintenance.

Sediment Basin

Monitoring Objective: Validate that runoff is being directed into basins, sediment accumulation is evident within the basin.

Protocol: (1) Validate that there is no shortcutting of runoff prior to entering basin. (2) Assess level of sediment accumulation within basin. (3) When sediment reaches a level of one foot, remove with mechanical or hand methods. (4) Assess condition of outlet and verify there is no erosion at outlet or channelizing immediately downstream, and that outlet is not clogged or otherwise compromised. (5) If large sediment load is present since last inspection, determine source of contribution from upstream sources including access roads, terraces, and agricultural fields, and take corrective action at the source(s). (6) Record inspections and volume of any sediment removed.

Frequency: Perform periodic inspections of the basins after large rainfall events, and a minimum of every six months.

Conservation Cover

Monitoring Objective: Validate that vegetation covers 95% of field area and is sufficiently preventing erosion generation within the fields.

1 *Protocol:* (1) Assess the bare field crop rows for locations of sparse or non-existent vegetation. (2)
2 Inspect vegetation for dead or unhealthy elements. (3) Verify presence of erosion at the ends of
3 crop rows where they intersect access roads. (4) Assess the presence of scour within adjacent fields
4 or access roads immediately downstream from subject crop fields.

5 *Frequency:* Annually.

6 **Vegetated Filter Strip**

7 *Monitoring Objective:* Verify strip is functioning properly to remove accumulated sediment and other
8 pollutants.

9 *Protocol:* (1) Visually inspect strip after storm event and repair any ruts, rills, or gullies that have
10 formed. (2) Remove unevenly deposited sediment accumulation that will disrupt sheet flow. (3)
11 Reseed disturbed areas and take other measures to prevent concentrated flow through the filter
12 strip.

13 *Frequency:* Semi-annually.

14 **WWRF**

15 *Monitoring Objective:* Ensure compliance with existing facility administrative agreements with both
16 EPA and Hawai'i DOH-Safe Drinking Water Branch.

17 *Protocol:* WWRF to follow established methods for monitoring and sampling, that are compliant
18 with the administrative agreement requirements for both expired permits (not within scope of this
19 WHWMP).

20 *Frequency:* As required by permits.

21 **Honokōwai Structure #8**

22 *Monitoring Objective:* Evaluate that sediment capture is occurring by the debris port retrofitted filter.

23 *Protocol:* Estimate volume of sediment contained on retrofitted-filter during cleaning inspections.
24 Record findings.

25 *Frequency:* Concurrent with routine or as needed maintenance.

26 **Wahikuli Gulch**

27 *Monitoring Objective:* Evaluate that sediment capture is occurring by the debris port retrofitted filter.

28 *Protocol:* Estimate volume of sediment contained on retrofitted-filter during cleaning inspections.
29 Record findings.

30 *Frequency:* Concurrent with routine or as needed maintenance.

1 **Fertilizer Management Plan**

2 *Monitoring Objective:* To verify proper storage, application, timing, disposal, and other factors
3 related to implementation of nutrients.

4 *Protocol:* (1) Review management plans with facility personnel and conduct frequent trainings to
5 ensure proper use. (2) Amend applicable management plans as necessary to reflect changes in
6 application and usage as new data is introduced that results in improved efficiency.

7 *Frequency:* Annually; and when new personnel hold responsible charge of application methods.

8 **BAER Plan**

9 *Monitoring Objective:* Ensure the plan is up to date to reflect the current conditions of the watersheds
10 to which it applies.

11 *Protocol:* Update plans as necessary and coordinate with stakeholders.

12 *Frequency:* Annually.

13 **Baffle Box**

14 *Monitoring Objective:* (1) Qualitatively assess the amount of vegetation and rubbish trapped in the
15 entry grate. (2) Quantify the amount of sediment deposited per unit time in the boxes' chambers.
16 (3) Identify the chemical makeup of the substances contained in the deposited sediments.

17 *Protocol:* Access to the inside of a baffle box is obtained via ports or manholes located above each of
18 the boxes' chambers. (1) Visual assessment of the type and quantity of gross solids (e.g., vegetation,
19 rubbish, and other materials) should be made and recorded. (2) The volume of sediment particles
20 in each of the chambers is the product of the average sediment layer thickness in each chamber and
21 its area. The volumetric measure can be converted to mass by multiplying the volume times an
22 average particle density. Thickness of the deposition layers can be determined using a graduate rod
23 or other measuring instrument. To account for variability of the thickness of the deposition layer,
24 four samples located at middle point along each of the chamber's walls should be collected and a
25 mean thickness computed. (3) Sediment grab samples can be collected and sent to a laboratory to
26 determine composition.

27 *Frequency:* Biennially or prior to vault cleanout.

28 **Bioretention Cell**

29 *Monitoring Objective:* Verify sediment volume within rain garden and verify vegetative/mulch
30 coverage on surface.

31 *Protocol:* Estimate sediment volume after determining if upstream contributions are inhibiting the
32 infiltration capacity of the rain garden.

33 *Maintenance:* (1) Remove accumulated sediment and dispose of in landfill. (2) Verify presence of
34 mulch layer and replace as necessary if mulch has dislodged and exposed underlying soil layers.

35 *Frequency:* Once per year, or after large volume/intensity storm event.

1 **SECONDARY MANAGEMENT PRACTICES**

2 **Curb Inlet Basket (with Filter)**

3 *Monitoring Objective:* Evaluate if gross solids are being captured.

4 *Protocol:* Document type and estimate volume of gross solids contained on mesh grate during
5 cleaning inspections. Record composition of debris and estimate the dominant debris type.

6 *Frequency:* Concurrent with routine or as needed maintenance.

7 **Debris Removal**

8 *Monitoring Objective:* Assess site for introduction of extent of household, commercial, and other
9 wastes present at illegal debris dumps, and remove debris to maximum extent possible at time of
10 inspection.

11 *Protocol:* (1) Visually assess volume of debris present. (2) Determine whether removal can be
12 completed by hand or if machine methods are necessary. (3) For municipal solid wastes, dispose of
13 debris in landfill. (4) If potential hazardous wastes are present, determine which portions are
14 hazardous, and comply with all applicable regulations for hazardous waste disposal. (5) For all
15 other waste types, dispose of properly according to all applicable regulations for waste type.

16 *Frequency:* Annually.

17 **Erosion Control Blanket / Turf Reinforcement Mat**

18 *Monitoring Objective:* Assess existing blanket/mat locations for evidence of scouring or erosion,
19 assess overall condition of practices, and determine if repair actions, or additional corrective
20 practice implementation is necessary.

21 *Protocol:* (1) Visually assess condition of blankets/mats. (2) Determine whether repair action is
22 necessary. (3) Repair existing blankets/mats as necessary. (4) If additional blankets/mats are
23 required, install by hand methods. (5) Determine other areas in need of repair or practice
24 implementation.

25 *Frequency:* Every six months.

26 **Facility Stormwater Assessment**

27 *Monitoring Objective:* To verify assessments of facilities have taken place related to proper storage of
28 materials and conducting of activities that have the potential to release contaminants into the
29 environment.

30 *Protocol:* (1) Review records of assessments. (2) Ensure that applicable management practices are
31 implemented.

32 *Frequency:* One-time.

1 **Good Housekeeping Practices**

2 *Monitoring Objective:* To determine if behavioral changes are occurring, to what level, and if they are
3 reducing the generation of NPS pollutants.

4 *Protocol:* Conduct survey to document type, location, perceived effectiveness of implemented good
5 housekeeping practices, and effectiveness of educational and outreach methods.

6 *Frequency:* Annually

7 **Gutter Downspout Disconnection**

8 *Monitoring Objective:* Validate design is working.

9 *Protocol:* Visually inspect gutter discharge area during storm event to verify outlet is stabilized and
10 there is no evidence of erosion.

11 *Frequency:* Annually.

12 **Irrigation Water Management Plan**

13 *Monitoring Objective:* To verify proper application, timing, disposal, and other factors related to
14 application of irrigation water on maintained properties.

15 *Protocol:* (1) Review management plans with facility personnel and conduct frequent trainings to
16 ensure proper use. (2) Amend applicable management plans as necessary to reflect changes in
17 application and usage as new data is introduced that results in improved efficiency.

18 *Frequency:* Annually and when new personnel hold responsible charge of application practices.

19 **Natural/Native/Drought Resistant Vegetation**

20 **Honokōwai Structure #8 and Sediment Basin Embankments**

21 *Monitoring Objective:* Validate through visual estimation that full vegetative cover is established on
22 embankments.

23 *Protocol:* (1) Validate that the embankment has a minimum of 75% vegetative cover over its length,
24 extending to the toe of the slope inside the basin up to the crest of the embankment, and the same
25 for the exterior of the structure on all sides. (2) Validate that vegetation has a healthy appearance
26 and that there are no sparse or dead areas of vegetation that could develop into erosion hotspots.

27 *Frequency:* Inspect once annually.

28 **Bare Soil Areas**

29 *Monitoring Objective:* Validate through visual estimation that full vegetative cover is established on
30 former exposed areas.

31 *Protocol:* (1) Validate that the location has a minimum of 75% vegetative cover over its areal extent,
32 and blends evenly into the existing vegetation surrounding the hotspot. (2) Validate that vegetation

1 has a healthy appearance and that there are no sparse or dead areas of vegetation that could
2 develop into erosion hotspots. (3) If hotspot is near a paved roadway, inspect nearby road surface
3 for staining or accumulated sediment for evidence of sediment transported down road and into
4 closed drainage system (if present) during past storm events. (4) If road unpaved, look for evidence
5 of rilling and transport of sediment onto the access road surface as indication that vegetation is not
6 fully established and rooted.

7 *Frequency:* Annually.

8 **Terraces**

9 *Monitoring Objective:* Validate through visual estimation that full vegetative cover is established
10 throughout the pineapple terraces.

11 *Protocol:* (1) Validate that the terrace has a minimum of 75% vegetative cover and there is no more
12 than 6" depth of sediment. (2) Validate that vegetation has a healthy appearance and that there are
13 no sparse or dead areas of vegetation that could develop into erosion hotspots.

14 *Frequency:* Inspect annually.

15 **Sideslopes of Roads at Stream Crossings**

16 *Monitoring Objective:* Validate the stability of the side slope and resistance to erosion through rill or
17 gully action.

18 *Protocol:* (1) Validate that the slope is not forming rills or gullies, and that undermining of the slopes
19 is not present at the toe of slope where it intersects existing ground. (2) If vegetation is used for
20 slope stability, verify that there is substantial cover and there are not vegetative losses resulting
21 from erosion. If riprap or other construction material is used for stability, verify that undermining
22 of the slope is not occurring within the slope or at the toe of slope. (3) Inspect stream channel for
23 evidence of sediment accumulation. (4) Verify that there are no contributing stormwater sources
24 from the road surface or upslope contributions that are causing channelization down the sideslope.

25 *Frequency:* Inspect annually.

26 **Pesticide Management Plan**

27 *Monitoring Objective:* To verify proper storage, application, timing, disposal, and other factors
28 related to implementation of pesticides.

29 *Protocol:* (1) Review management plans with facility personnel and conduct frequent trainings to
30 ensure proper use. (2) Amend applicable management plans as necessary to reflect changes in
31 application and usage as new data is introduced that results in improved efficiency.

32 *Frequency:* Annually and when new personnel hold responsible charge of application methods.

33 **Pond Sampling Plan**

34 *Monitoring Objective:* To evaluate pollution contributions from golf course and other urban areas
35 draining to ponds.

1 *Protocol:* (1) Perform grab samples of pond water. (2) Submit to State certified laboratory for
2 analysis of nitrogen, phosphorus, TSS, and other common landscape/urban-generated constituents.

3 *Frequency:* Annually.

4 **Riprap**

5 *Monitoring Objective:* (1) Validate that riprap and geotextile are properly stabilizing the underlying
6 soils and preventing erosion.

7 *Protocol:* (1) Assess the presence of rills or erosion at the toe of the riprap slope. (2) If erosion is
8 present, assess placement of existing riprap and geotextile and determine if additional coverage is
9 necessary. (3) Complete placement of geotextile and riprap using hand / mechanical methods as
10 necessary to fully cover affected area.

11 *Frequency:* Annually

12 **Shoreline Erosion Control**

13 *Monitoring Objective:* To quantify reduction rates of shoreline retreat due to erosion.

14 *Protocol:* Establish transects to measure position of shoreline over time. Use photographic
15 monitoring points to qualitatively assess changes over time.

16 *Frequency:* Annually.

17 **Storm Sewer Disconnection**

18 *Monitoring Objective:* To determine whether measures installed in place of storm sewer system are
19 effectively conveying runoff while encouraging settling of solids.

20 *Protocol:* (1) Inspect area of natural system / vegetated channel and note if areas of erosion are
21 present. (2) Inspect area for accumulated trash, debris, and sediment. (3) Inspect area at receiving
22 water body or point discharge from site and note any visual evidence of pollutants remaining from
23 runoff events.

24 *Frequency:* Annually.

25 **Vegetated Swale**

26 *Monitoring Objective:* To validate design is working.

27 *Protocol:* Visually inspect swales during runoff events to assess if water is retained and following
28 event to verify that stagnant water conditions do not occur.

29 *Frequency:* Annually.

1 **Vehicle Washwater Containment**

2 **Monitoring Objective:** To determine whether containment methods are effectively preventing
3 migration of washwater into drainageways.

4 **Protocol:** (1) Inspect area immediate to washwater containment. (2) Inspect area for evidence of
5 liquid migration of spent washwater onto impervious or pervious surfaces. (3) Adjust containment
6 system as necessary to prevent migration.

7 **Frequency:** Each washing event.

8 **Illicit Dumping Signage**

9 **Monitoring Objective:** To determine signage is intact and in place.

10 **Protocol:** (1) Verify presence of signage at dumping location. (2) Repair or replace signage as
11 necessary.

12 **Frequency:** Annually.

1 **Appendix E. Community Input**

2 **E.1. List of Persons Consulted**

3 The following individuals were consulted during the development of the WHWMP, either through
4 personal communication, interviews, or attendance at meetings.

- 5 Abraham, Ka'au, Hawaiian Humpback Whale National Marine Sanctuary
- 6 Ampong, Foster, Aha Moku Council
- 7 Asakura, Roland, DOH CWB Compliance Section
- 8 Brosius, Chris, WMMWP
- 9 Bulson, Gary, Kā'anapali Operations Association
- 10 Critchlow, Paul, County of Maui, Department of Planning
- 11 Fernandez, Kyle, student
- 12 Fiat, Mark
- 13 Foote, Liz, CORAL
- 14 Fukunaga, Chad, KLMC
- 15 Ganske-Cerizo, Ranae, NRCS
- 16 Gazmen, Glenn, Kā'anapali Operations Association
- 17 Goode, David, County of Maui, Department of Public Works
- 18 Halverson, Robert, County of Maui, Department of Parks and Recreation
- 19 Hamilton, Chris, Maui News
- 20 Hashimoto, Carl, NRCS
- 21 Hayama, Michael, NRCS
- 22 Hedani, Wayne, Kā'anapali Operations Association
- 23 Hew, Chauncey, DOH Safe Drinking Water Branch, UIC Program
- 24 Jorgensen, Mary, County of Maui, Department of Planning
- 25 Kaniaupio-Crozier, Pomaika'i, ML&P
- 26 Kukahiko, Earl, County of Maui, Department of Public Works, Highways Division
- 27 Kuloloio, Les, Aha Moku Council
- 28 Landon, Anne, Haiku
- 29 McCarthy, Richard, Aha Moku Council
- 30 Matsui, Patrick, County of Maui, Department of Parks and Recreation
- 31 McLane, Sarah, WMMWP
- 32 Medeiros, Bill, County of Maui, Geographic Information Systems Program
- 33 Merrick, Michael & Julie, Makai Watch Volunteers
- 34 Migita, Reef, DOH CWB Permitting Section
- 35 Murphy, Sheila, Makai Watch Volunteers
- 36 Nims, Kira, WMSWCD
- 37 Nohara, Wes, Puu Kane Farms LLC
- 38 Okubo, Watson, DOH CWB Monitoring & Analysis Section
- 39 Ornellas, Daniel, DLNR Land Division
- 40 Petty, Bo, NOAA Sanctuaries
- 41 Pogue, Pam, County of Maui Board of Water, Water Resources & Planning Program
- 42 Potts, Les, Community at Large
- 43 Pueschel, Joe

- 1 Rebugio, Jeff, KLMC
- 2 Reed, Adam, NRCS Pacific Islands Area
- 3 Rollins, Scott, County of Maui, Lahaina Wastewater Reclamation Facility
- 4 Seebart, John, Slower Road, Makai Watch
- 5 Segura, Mike, Kā'anapali Operations Association
- 6 Slay, Hudson, EPA
- 7 Sparks, Russell, DLNR-DAR
- 8 T, Mike, County of Maui, Department of Public Works
- 9 Takeno, Ty, County of Maui, Department of Public Works
- 10 Taylor, P.
- 11 Thomson, Richelle, County of Maui, Department of Corporation Counsel
- 12 Trenholme, Craig, Kā'anapali Golf Course Superintendent
- 13 Wakida, Penny
- 14 White, Darla, University of Hawaii/State of Hawaii Division of Aquatic Resources
- 15 Wiltse, Wendy, EPA
- 16 Yamashige, Eric, County of Maui, Department of Public Works, Highways Division
- 17 Yamashita, Cary, County of Maui, Department of Public Works
- 18 Yamashita, David, County of Maui, Department of Planning

19 **E.2. Public Input**

20 The following notes were compiled from the October 2, 2012 public meeting to review the *Draft*
21 *WHWMP Volume 2: Strategies and Implementation*.

22 **Question and Answer Session**

23 **Why was there not more emphasis on the chemical inputs that affect coral and less on the**
24 **sediment issues?** Agricultural chemicals are diffuse and there are many unknowns about the sub-
25 surface paths. When it comes to cleaning up an aquifer, this is a very large challenge. The plan does
26 support in increase in the reuse of R1 water as per the County of Maui plans.

27 **What is the County R1 Plan?** It involves a gradual increase in the infrastructure needed to store,
28 pressurize and transmit R1 water. It is very costly to expand the needed infrastructure.

29 **What are the plans for the former Monsanto lands? Is there a plan or funding to secure it for**
30 **conservation?** This is private land that was leased to Monsanto. Installing conservation cover is
31 what is recommended in the plan. One of the challenges with this is the limited supply of water and
32 water cannons needed to speed up establishment of a cover. They currently seem to be planning on
33 waiting until the rain comes, and allowing weeds to establish as a cover, which while better than
34 nothing, creates other challenges (weed seed stock and fire hazard once dry).

35 **There is confusion about the implementation plan- proposing and then defending is the**
36 **wrong approach. Kaanapali moku is cut up, and needs to be considered all the way to**
37 **Kahakaloa. NOAA and other agencies are avoiding dealing with the problems on the reef.**
38 **Toxicology and disease are the problems the agencies are running from. UH and USGS are**
39 **working on this. Start with the problem, not by looking at the land. Identify the coral makeup**
40 **for the entire island and over to Molokai. There needs to be a current study on this**
41 **information.** USGS is currently doing a study, DAR is tracking this issue, NOAA is doing

1 contaminant work, and once complete this information will be shared. This meeting was focused on
2 the watershed plan, which is one approach to these problems.

3 **The focus has two faces; the coral and looking mauka. Are there other studies looking at why**
4 **the reef is dying? Reefs don't follow boundaries. The two faces create confusion.** Once there
5 are research finding about coral health, there could be public events to share this info. This is a two
6 pronged approach- continue to study the coral problems while starting planning and
7 implementation on a watershed plan that addresses some of the known issues.

8 **What are the causes of reef damage? Can we do tests and address the specific causes?**
9 Nutrients and sediment are known to cause problems. There are now new studies using bio-
10 markers and genetic tools to help make some of the direct connections to other substances. As
11 these hi-tech tools come into use, we get more information about the specific causes of coral
12 decline.

13 **In Lahaina and Kihei we know that coral infections came with the sugar cane industry.**
14 **Problems have been identified.**

15 Coral monitoring is ongoing, and this is information that likely should be shared more broadly.
16 There are other pressures on coral, such as over fishing, land pollutants, climate change and ocean
17 acidification.

18 There are overlapping efforts in the area to concentrate focus. The hope is this will help to inform
19 and direct plans in other areas as well.

20 DAR was thrilled that there was so much awareness of disease and encouraged others to join the
21 eyes of the reef training and network to help capture information about changes on our reefs.

22 **Why was there not more emphasis on land owners? Baffle boxes in parks and 60-something**
23 **screens- who wants that? This creates more work for Public Works who have less funding**
24 **and labor each year while land owners who have made their money over 100 years are**
25 **taking no responsibility for their action.** There is agreement that the ag district is the
26 appropriate emphasis for priority action. There are few regulations that are enforceable that this
27 adds to the challenge.

28 **It would be helpful is there was conservation cover, and even more food grown.**

29 **We need help from the feds to help limit growth of developments.**

30 **Breakout Sessions**

31 **Additional Implementation practices**

- 32 • Pass legislation that creates a requirement that large agricultural businesses reserve a fund
33 for returning land to a protected state (such as replanting)
- 34 • Community pressure: host meetings with land owners and the community to encourage re-
35 vegetation, possibly with edibles?
- 36 • Investigate need for rule changes to ag land practices: BMPs, county/state; how to change
37 and how to facilitate change

- 1 • Let the public have a say/vote on whether to upgrade the LWWRP, like a referendum; ask
- 2 Chair Aila for support, assess the public readiness
- 3 • Balance conservation with development actions
- 4 • Protect traded land forever
- 5 • Make landowners responsible for vegetative cover on fallow fields
- 6 • Consider the costs of maintenance
- 7 • Federal level regulations for all issues and impacts, EPA, ESA for coral
- 8 • State and county planning
- 9 • Place reservoirs and retention basins more mauka to collect water for irrigation and to
- 10 catch sediment before it reaches the ocean/low lands and needs remediation
- 11 • Work with DLNR permitting bio-rock
- 12 • Coral-safe sunscreens

13 **Suggestions for groups, organizations, companies, agencies or individuals who can help**

14 **with:**

15 **Monitoring:**

16 Water Quality

- 17 • NOAA Sanctuaries
- 18 • Makai Watch

19 Reef

- 20 • NOAA Sanctuaries
- 21 • Digital Bus
- 22 • Makai Watch

23 **Education:**

24 Hotels

- 25 • Maui Ocean Center
- 26 • Makai Watch

27 Schools

- 28 • NOAA Sanctuaries
- 29 • Digital Bus
- 30 • Maui Preparatory Academy
- 31 • Lahainaluna High School

32 Better Agricultural Practices & Landscapers:

- 33 • Maui Nui Botanical Gardens

34 Ocean Users

- 35 • NOAA Sanctuaries
- 36 • Digital Bus

- 1 Neighborhoods
- 2 • NOAA Sanctuaries

3 **Topics of Interest to Learn More About**

- 4 • The impact of ag to urban transition, planned development
- 5 • Where the implementation chart costs were sourced from and who is expected to pay;
- 6 taxpayers? Property owners?
- 7 • Kahoma, 24,000 cubic yards of sediment from the basin
- 8 • Host follow up meetings to Vol.2 to discuss scientific research being conducted on the coral-
- 9 include previous and ongoing studies, and share current state of knowledge

10 **Comment Forms**

11 One was completed: resident of Mahinahina who thinks bare ag lands are the biggest contributor,
12 understands the WMP and agrees with suggestions. She thinks community pressure needs to be
13 applied through meetings with land owners and the community to reduce ag pollution. For
14 fertilizers, information on the damage being done should be presented and alternatives shared. To
15 encourage participation of land owners send mailings and put in the paper.- Shelia Murphy

16

1 This page intentionally left blank

1 **Appendix F. Information Cited**

2 **F.1. References**

- 3 Bio Clean. 2009. "Bio Clean Environmental Services, Inc., Oceanside CA,
4 <http://www.biocleanenvironmental.com/>."
- 5 County of Maui Department of Environmental Management. 2010. Maui's Wastewater Management
6 Future: Charting a Course to Increased Water Recycling and Reduced Reliance on Injection
7 Wells. Report and Recommendations of Maui Wastewater Community Working Group.
- 8 Environmental Protection Agency. 1993. Guidance Specifying Management Measures for Sources of
9 Nonpoint Pollution in Coastal Waters. EPA 840-B-92-002. U.S. Environmental Protection
10 Agency, Washington, DC. January. <http://www.epa.gov/owow/NPS/MMGI/index.html>
- 11 Environmental Protection Agency. 1997. Monitoring guidance for determining the effectiveness of
12 nonpoint source controls. EPA 841-B-96-004. Office of Water, Washington, DC. September
13 1997.
- 14 Environmental Protection Agency. 2001. Techniques for Tracking, Evaluating, and Reporting the
15 Implementation of Nonpoint Source Control Measures - Urban. EPA 841-B-00-007. U.S.
16 Environmental Protection Agency, Washington, DC.
- 17 Environmental Protection Agency. 2002. Guidance for Quality Assurance Project Plans. EPA QA/G-
18 5, U.S. Environmental Protection Agency, Office of Environmental Information, Washington, D.C.
19 <http://www.epa.gov/quality/qs-docs/g5-final.pdf>.
- 20 Environmental Protection Agency. 2003. National menu of best management practices for storm
21 water Phase II. Washington, DC, Office of Water:
22 <http://cfpub.epa.gov/npdes/stormwater/menuofbmps/index.cfm>.
- 23 Environmental Protection Agency. 2005. National Management Measures to Control Nonpoint
24 Source Pollution from Urban Areas. Washington, D.C., U.S. Environmental Protection Agency.
- 25 Environmental Protection Agency. 2007. National Management Measures to Control Nonpoint
26 Source Pollution from Hydromodification. Washington, D.C., U.S. Environmental Protection
27 Agency.
- 28 Environmental Protection Agency. 2008a. Development of Duration-Curve Based Methods for
29 Quantifying Variability and Change in Watershed Hydrology and Water Quality . EPA 600-R-08-
30 065. U.S. Environmental Protection Agency, Washington, DC.
- 31 Environmental Protection Agency. 2008b. Handbook for Developing Watershed Plans to Restore
32 and Protect Our Waters. Washington, D.C., U.S. Environmental Protection Agency.
- 33 Field, R., A. N. Tafuri, et al. 2004. The Use of Best Management Practices (BMPs) in Urban
34 Watersheds. Lancaster, PA, DEStech Publications, Inc.
- 35 GeoSyntec and ASCE. 2002. GeoSyntec Consultants Urban Drainage and Flood Control District and
36 Urban Water Resources Council of ASCE (GeoSyntec and ASCE). Urban stormwater BMP
37 performance monitoring: a guidance manual for meeting the national stormwater BMP
38 database requirements. EPA 821/B-02/001. U.S. Environmental Protection Agency, Office of
39 Water, Washington, DC.
- 40 ITFM. 1995. The strategy for improving water-quality monitoring in the United States. Final report
41 of the Intergovernmental Task Force on Monitoring Water Quality. Intergovernmental Task
42 Force on Monitoring Water Quality (ITFM), Interagency Advisory Committee on Water Data,
43 Washington, DC + Appendices.

1 LA-SMD. 2000. Reference Guide for Stormwater BMPs. City of Los Angeles, California, Stormwater
 2 Management Division, Bureau of Sanitation, Department of Public Works City of Los Angeles.
 3 Maui County Council. 1996. The West Maui Community Plan.
 4 Natural Resources Conservation Service. 2008. Water and Sediment Control Basin. Code 638.
 5 September.
 6 Natural Resources Conservation Service. 2010. Conservation Practice Standard: Access Road. Code
 7 560. July.
 8 Natural Resources Conservation Service Pacific Islands Area. 2011a. Conservation Practice
 9 Standard: Sediment Basin.
 10 Natural Resources Conservation Service Pacific Islands Area. 2011b. Conservation Practice
 11 Standard: Terrace.
 12 Natural Resources Conservation Service Pacific Islands Area. 2011c. Conservation Practice
 13 Standard: Filter Strip.
 14 Natural Resources Conservation Service Pacific Islands Area. 2012. Conservation Practice Standard:
 15 Stream Crossing.
 16 NOAA Coral Reef Conservation Program. 2012. Land-Based Sources of Pollution Implementation
 17 Plan FY 2011 – FY 2015. April.
 18 [http://coralreef.noaa.gov/aboutcrp/strategy/reprioritization/wgroups/resources/lbsp/welcome.](http://coralreef.noaa.gov/aboutcrp/strategy/reprioritization/wgroups/resources/lbsp/welcome.html)
 19 [html](http://coralreef.noaa.gov/aboutcrp/strategy/reprioritization/wgroups/resources/lbsp/welcome.html)
 20 Silva, J. A. and R. Uchida, eds. 2000. Plant Nutrient Management in Hawaii’s Soils, Approaches for
 21 Tropical and Subtropical Agriculture. College of Tropical Agriculture and Human Resources,
 22 University of Hawaii at Manoa.
 23 Stewart, C. 2010a. Hawaii’s Management Measures for the Coastal Nonpoint Source Pollution
 24 Control Program DOH Clean Water Branch Polluted Runoff Control Program, Marine and
 25 Coastal Solutions International.
 26 Stewart, C. 2010b. Responsible Agencies and Authorities - A Supplemental For Hawaii Management
 27 Measures. Hawaii DOH Clean Water Branch Polluted Runoff Control Program.
 28 Strecker, E. W., M. M. Quigley, et al. 2001. “Determining Urban Storm Water BMP Effectiveness.”
 29 *Journal of Water Resources Planning and Management.* 127(3): 144-149.

30 **F.2. Personal Communication**

31 Asakura, R. 2012. Department of Health Clean Water Branch (Personal Communication).
 32 Migita, R. 2012. Department of Health Clean Water Branch (Personal Communication).
 33 Hashimoto, C. 2012. NRCS Soil Conservation Technician (Personal Communication).
 34 Maui County. 2012. Various County of Maui Personnel (Personal Communication).
 35 Okubo, W. 2012. Department of Health Clean Water Branch (Personal Communication).
 36 Wiltse, W. 2012. U.S. Environmental Protection Agency (Personal Communication).
 37

1 **F.3. Geospatial Data**

2 Geospatial data was obtained primarily from public data sources and non-profit groups.

3 **Department of Business, Economic Development & Tourism (DBEDT)** files and associated
4 metadata are available for download at <http://www.hawaii.gov/dbedt/gis/download.htm>. DBEDT
5 files are in the following projection: Universal Trans Mercator, Zone 4, NAD 83.

6 **Hawai'i Gap Analysis Program (HI-GAP)** files and associated metadata were from HI-GAP at
7 <ftp://ftp.gap.uidaho.edu/products/Hawaii/>. HI-GAP files are in the following projection: Universal
8 Trans Mercator, Zone 4, NAD 83.

9 **Natural Resources Conservation Service (NRCS)** files and associated metadata are available for
10 download at <http://soildatamart.nrcs.usda.gov/>. Zipped file (containing all files for the soil
11 shapefile for the Island of Maui, including metadata) is current as of July 2012. NRCS files are in the
12 following projection: State Plane Hawai'i, Zone 3, NAD 83.

13 **NOAA/DOC/NOS/NCCOS/CSC** files and associated metadata are available for download from
14 *National Oceanic and Atmospheric Administration* (NOAA) (see shapefile and associate .txt file for
15 contact information for source; <http://www.csc.noaa.gov/ccap/pacific/honolulu/index.html> and
16 http://sanctuaries.noaa.gov/library/imast_gis.html). NOAA files are in the following projection:
17 State Plane Hawai'i, Zone 3, NAD 83.

18 **West Maui Mountains Watershed Partnership (WMMWP)** files and associated metadata were
19 obtained from the WMMWP GIS database. WMMWP files are in the following projection: Universal
20 Trans Mercator, Zone 4, NAD 83.